

AD000014

Accessories • Assembly - quick clips

accessories pressure, Quick clip, 30x22x16mm, Holder, Plastic, 90°



Mechanical features

| | |
|-------------------------------|----------------|
| Width | 16 mm |
| Diameter of screw-on mounting | 6 |
| Height | 30 mm |
| Length | 22.5 mm |
| Mounting method | Screw mounting |
| Material | Plastic |
| Angle | 90 ° |
| Accessories for | DW16 |

Classification

| | |
|--------|---|
| ETIM 8 | EC002625 Mounting accessories (control cabinet) |
|--------|---|

More

| | |
|-----------------------|-------------------|
| IPF Product Group | 900 accessories |
| packaging dimensions | 130 x 100 x 16 mm |
| gross weight | 10 g |
| Customs tariff number | 39269097 |
| WEEE number | 40951076 |
| Reach-compliant | Yes |
| RoHS-compliant | Yes |

Dimensional drawing

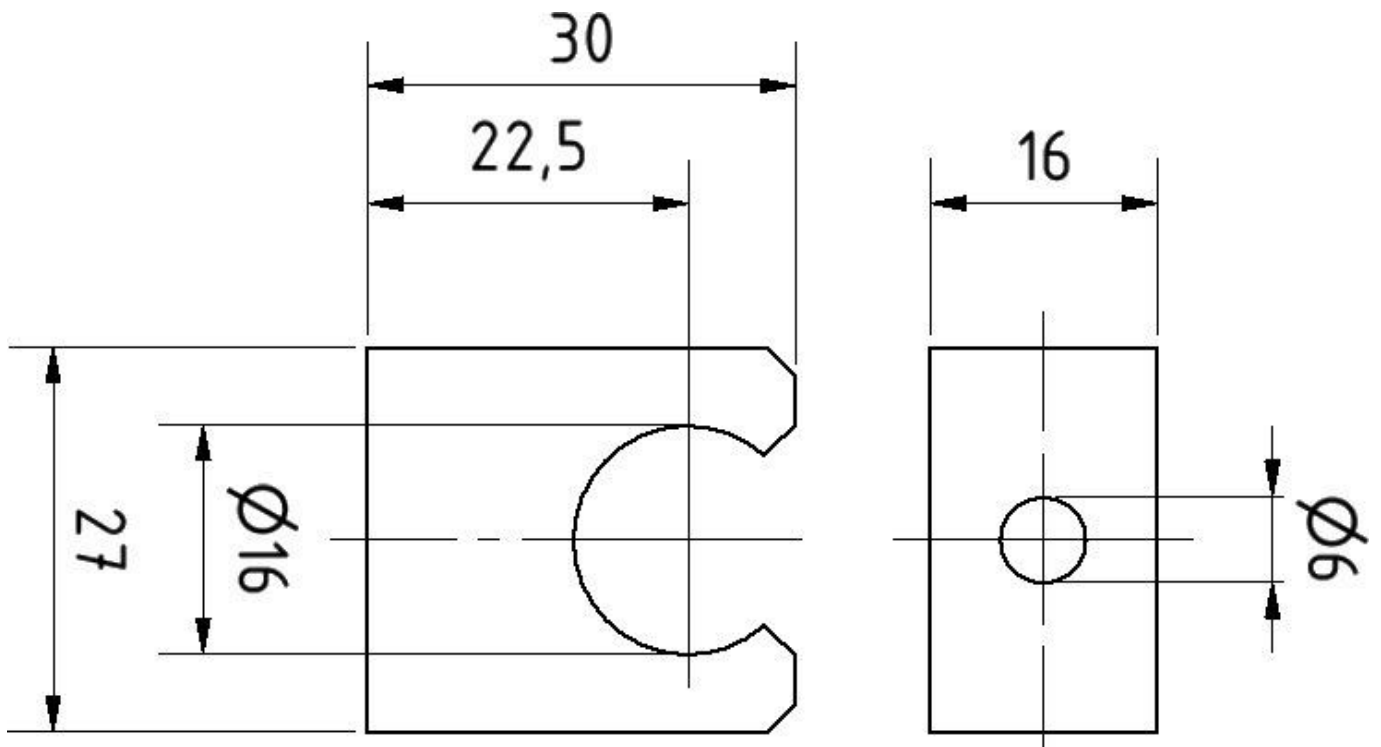

Installation

Mounting / installation may only be carried out by a qualified electrician!



Disposal

WEEE number according to § 6 para. 3
ElektroG: 40951076

Safety warnings

- / Before initial operation, please make sure to follow all safety instructions that may be provided in the product information.
- / Never use these devices in applications where the safety of a person depends on their functionality.