

## AD000016

### Accessories • Fluid technology - Fitting panels

accessories pressure, Mounting bracket with adapter flange, 44x16x31mm, Adaption, mounting material and bracket, External thread 1/8" - 6mm, Steel, 90°

including Mounting bracket, Spring washer, Flange, Screw, Washer



#### Mechanical features

Adaption	External thread 1/8" - 6mm
Width	31.3 mm
Diameter of screw-on mounting	3.2
Height	44 mm
Length	16.2 mm
Mounting method	Screw mounting
Surface	Galvanized
Material	Steel
Angle	90 °

#### Classification

ETIM 8	EC002625 Mounting accessories (control cabinet)
--------	---

#### More

IPF Product Group	900 accessories
packaging dimensions	140 x 80 x 25 mm
gross weight	41 g
Customs tariff number	73269098
WEEE number	40951076
Reach-compliant	Yes
RoHS-compliant	Yes

**Dimensional drawing**

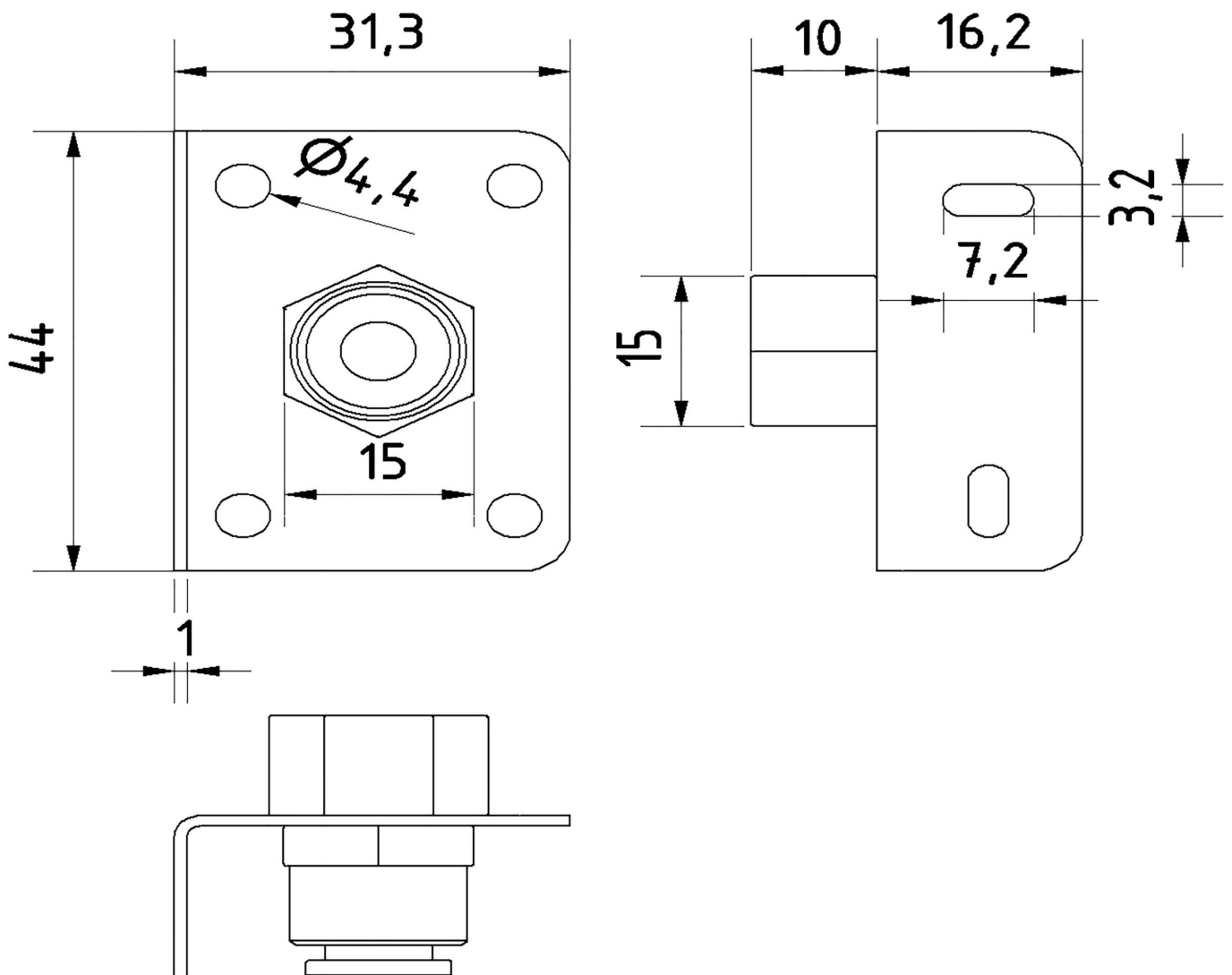

**Installation**

Mounting / installation may only be carried out by a qualified electrician!



**Disposal**

WEEE number according to § 6 para. 3  
ElektroG: 40951076

**Safety warnings**

- / Before initial operation, please make sure to follow all safety instructions that may be provided in the product information.
- / Never use these devices in applications where the safety of a person depends on their functionality.