

AD000024

Accessories • Assembly - quick clips

Accessories Pressure, holder for Dx08, 23x40x40mm, plastic, addable



Holder for DW08

Mechanical features

Width	23 mm
Diameter of screw-on mounting	4.8
Height	40.5 mm
Length	40 mm
Mounting method	Screw mounting
Material	Plastic
Accessories for	Dx08

Classification

ETIM 8

More

IPF Product Group	900 accessories
packaging dimensions	120 x 100 x 25 mm
gross weight	11 g
Customs tariff number	39269097
WEEE number	40951076
Reach-compliant	Yes
RoHS-compliant	Yes

Dimensional drawing

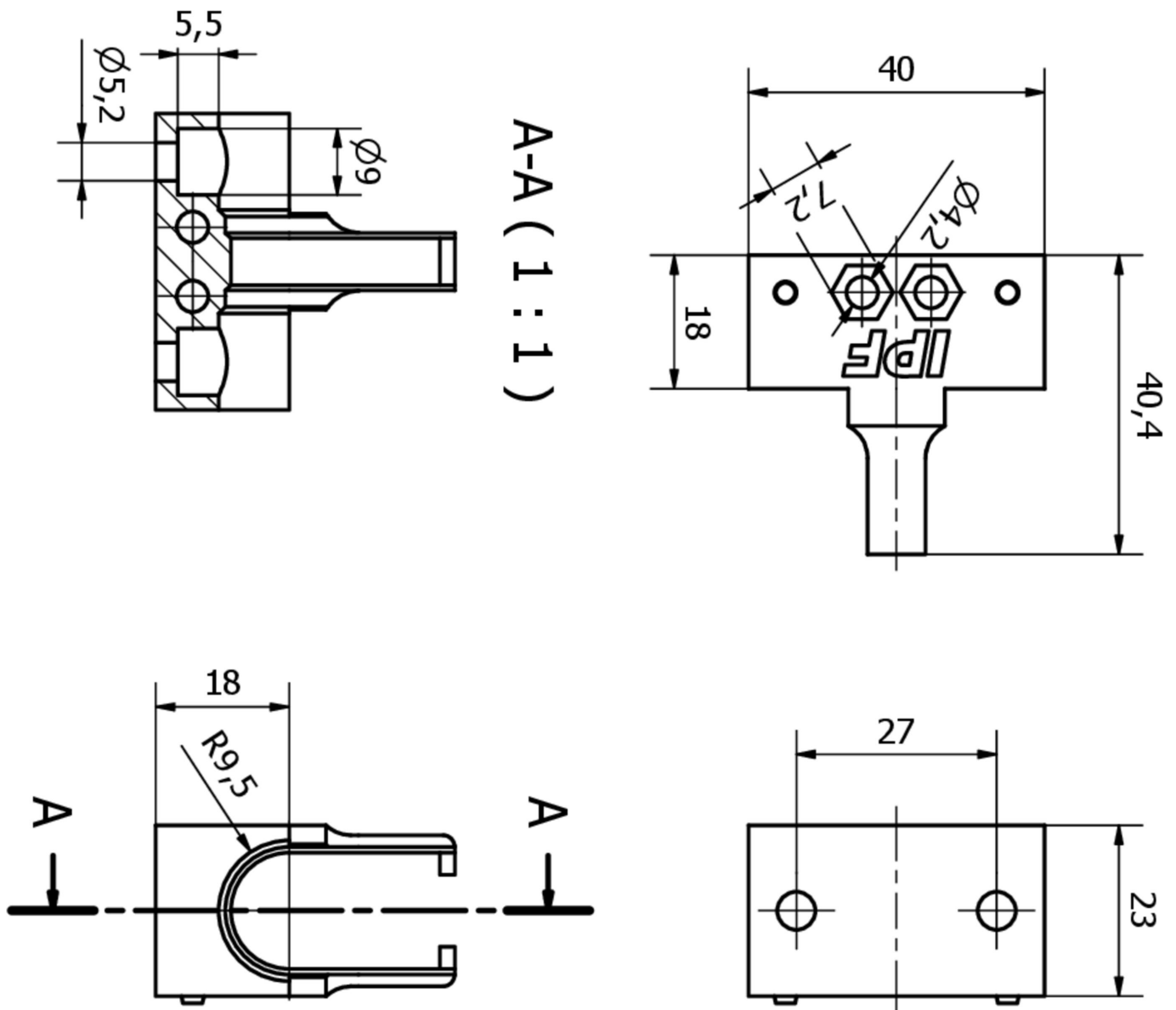

Installation

Mounting / installation may only be carried out by a qualified electrician!



Disposal

WEEE number according to § 6 para. 3
ElektroG: 40951076

Safety warnings

- / Before initial operation, please make sure to follow all safety instructions that may be provided in the product information.
- / Never use these devices in applications where the safety of a person depends on their functionality.