

AE000025

Accessories • LED light - Holding magnets

accessories lights, Adhesive magnet, Mounting material for lights, Steel



Light accessories, holding magnet, mounting material for light, steel

Mechanical features

Material	Steel
----------	-------

Other features

Version	Holding magnet
---------	----------------

Classification

ETIM 8	EC002625 Mounting accessories (control cabinet)
--------	---

More

IPF Product Group	900 accessories
packaging dimensions	130 x 85 x 45 mm
gross weight	62 g
Customs tariff number	85051190
WEEE number	40951076
Reach-compliant	Yes
RoHS-compliant	Yes

Dimensional drawing

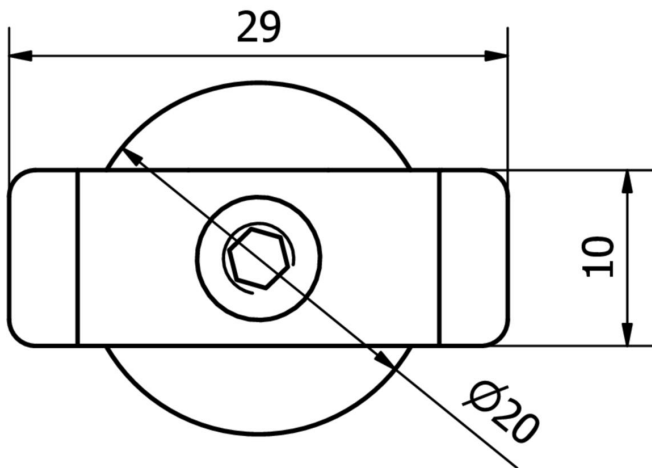
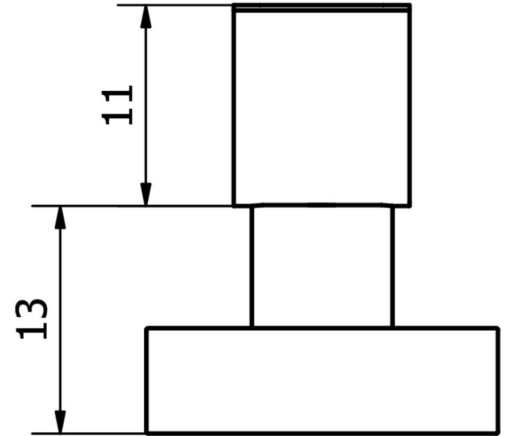
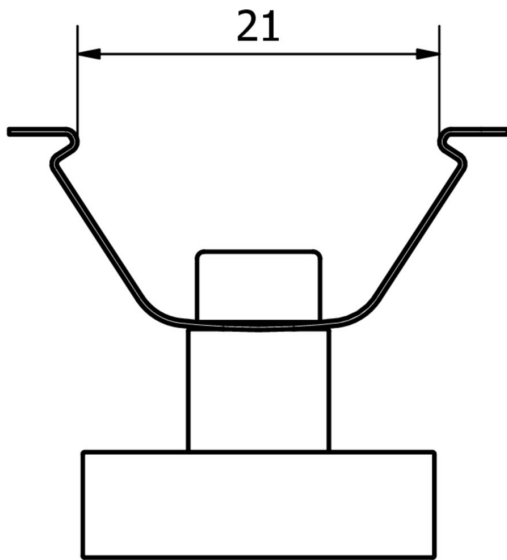

Installation

Mounting / installation may only be carried out by a qualified electrician!



Disposal

WEEE number according to § 6 para. 3
ElektroG: 40951076

Safety warnings

/ Before initial operation, please make sure to follow all safety instructions that may be provided in the product information.

/ Never use these devices in applications where the safety of a person depends on their functionality.