

AE000040

Accessories • Labeling

Accessories Mounting set for labeling plates for signal towers with Ø50mm , 167x25x16mm, plastic PA12

including Nut, Screw



Easy mounting of the plates for plain text labeling

This clamp holder is used to attach the labeling plates to the EZ500 signal lights. The labeling plate can be brought into the desired position by twisting it.

Mechanical features

Width	167 mm
Height	25 mm
Material thickness	16 mm
Mounting method	Direct mounting
Material	Plastic (PA, glass fiber reinforced)

Classification

ETIM 8

More

IPF Product Group	900 accessories
packaging dimensions	270 x 160 x 25 mm
gross weight	33 g
Customs tariff number	39269097
WEEE number	40951076
Reach-compliant	Yes
RoHS-compliant	Yes

Important notes

/ The holder can only be mounted in one direction, please pay attention to the chamfer on the inside. This is applied to the lower end of the luminaire housing to prevent vertical adjustment.

Dimensional drawing

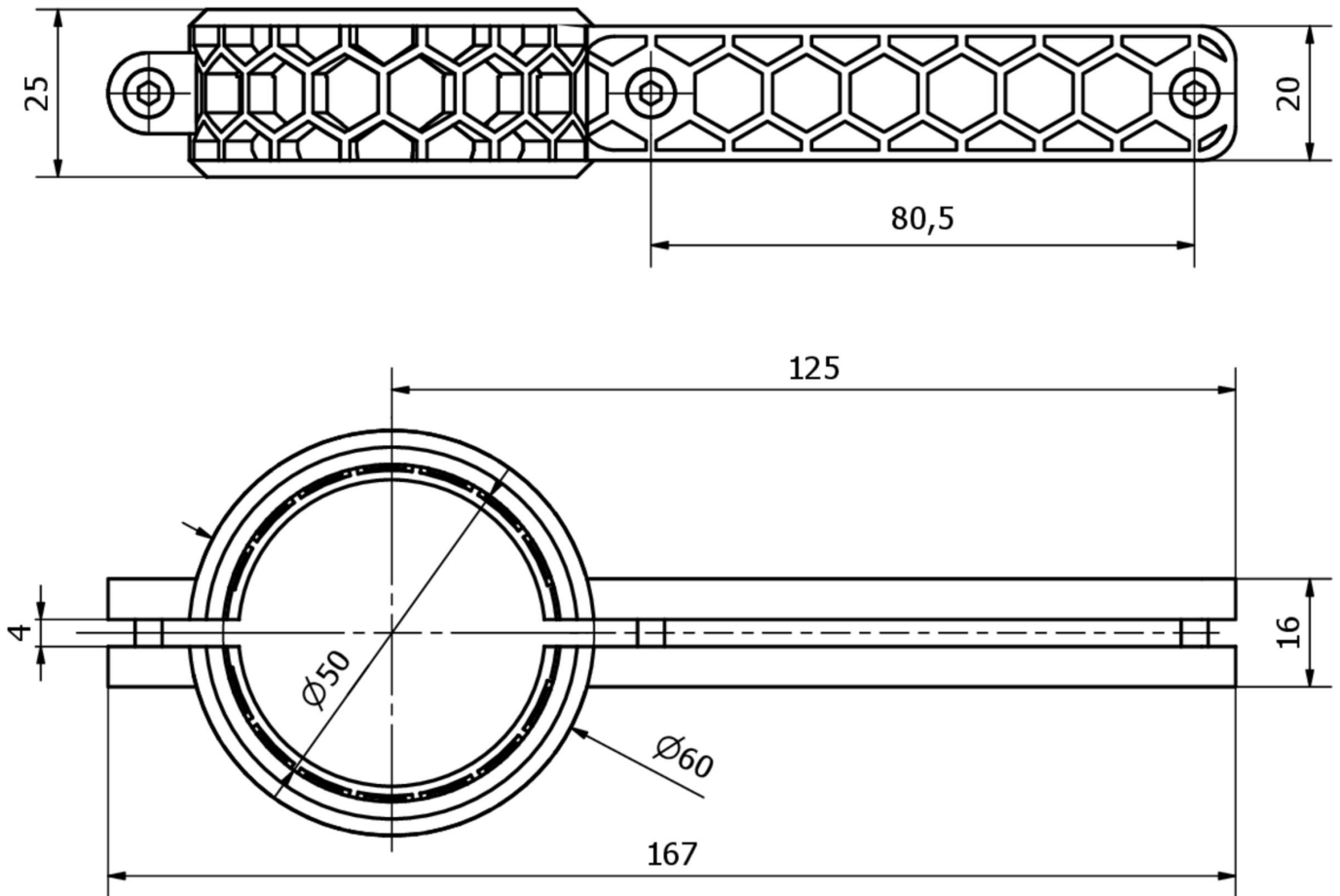

Extract accessories program

AE000043



Accessories for signal lights,
inscription plate, 164x150x4mm,
acrylic glass

AE000044



Accessories for signal lights,
inscription plate, 211x150x4mm,
acrylic glass

You can find further accessories on our homepage



Installation

Mounting / installation may only be carried out by a qualified electrician!



Disposal

WEEE number according to § 6 para. 3
ElektroG: 40951076

Safety warnings

/ Before initial operation, please make sure to follow all safety instructions that may be provided in the product information.

/ Never use these devices in applications where the safety of a person depends on their functionality.