

AM000111

Accessories • Other fixing material

accessories magnetic, Clamp, Ø3,6mm 6long, Metal



Mechanical features

Diameter	3.6 mm
Length	6 mm
Material	Metal

Other features

Version	Clamp
---------	-------

Classification

ETIM 8	EC002024 Accessories/spare parts for command devices
--------	--

More

IPF Product Group	900 accessories
packaging dimensions	100 x 70 x 5 mm
gross weight	24 g
Customs tariff number	73269098
WEEE number	40951076
Reach-compliant	Yes
RoHS-compliant	Yes

Dimensional drawing

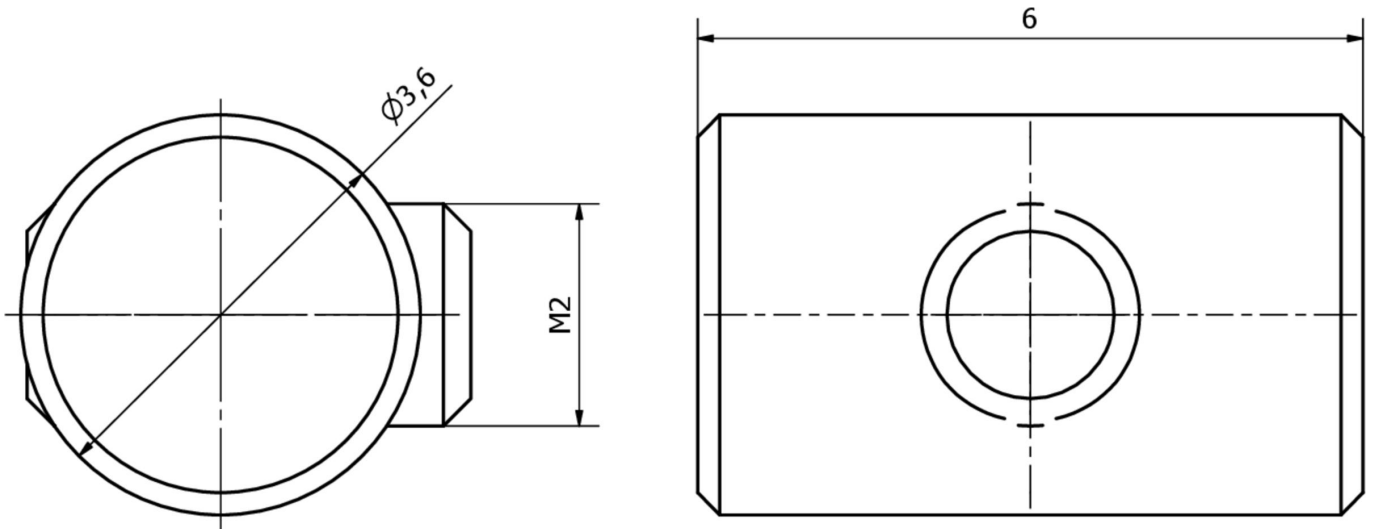

Installation

Mounting / installation may only be carried out by a qualified electrician!



Disposal

WEEE number according to § 6 para. 3
ElektroG: 40951076

Safety warnings

/ Before initial operation, please make sure to follow all safety instructions that may be provided in the product information.

/ Never use these devices in applications where the safety of a person depends on their functionality.