

## AO000045

### Accessories • Optical sensors - Assembly

accessories optical, Mounting angle bracket, 16x15x42mm, Mounting material for sensor, brackets, Steel, 90°

including Nut, Screw, Washer



#### Mechanical features

Width	42 mm
Diameter of screw-on mounting	4.2
Height	16.5 mm
Length	15 mm
Mounting method	Screw mounting
Surface	Galvanized
Material	Steel
Angle	90 °

#### Classification

ETIM 8	EC002625 Mounting accessories (control cabinet)
--------	---

#### More

IPF Product Group	900 accessories
packaging dimensions	100 x 120 x 17 mm
gross weight	21 g
Customs tariff number	73269098
WEEE number	40951076
Reach-compliant	Yes
RoHS-compliant	Yes

**Dimensional drawing**

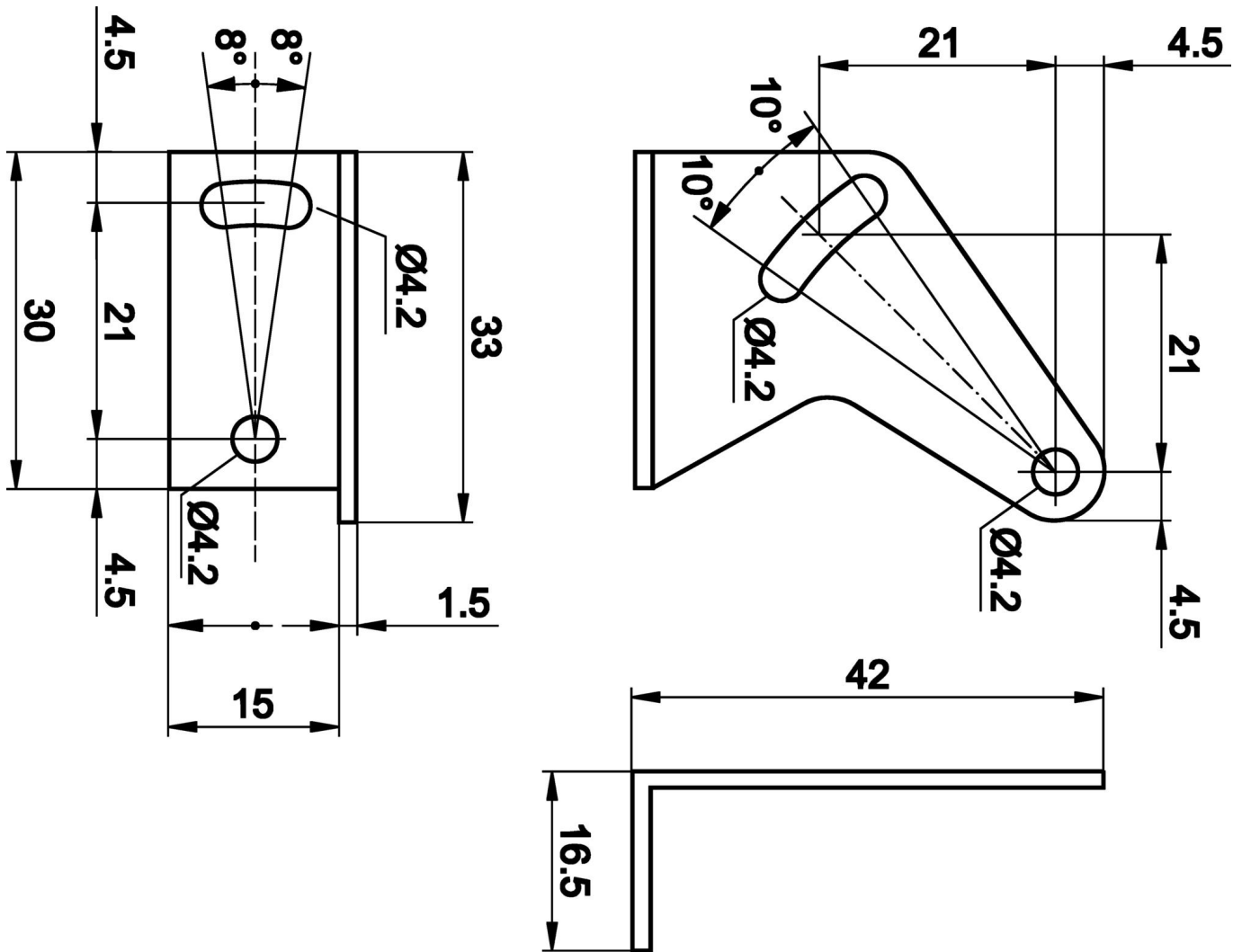

**Installation**

Mounting / installation may only be carried out by a qualified electrician!



**Disposal**

WEEE number according to § 6 para. 3 ElektroG: 40951076

**Safety warnings**

- / Before initial operation, please make sure to follow all safety instructions that may be provided in the product information.
- / Never use these devices in applications where the safety of a person depends on their functionality.