

# AO000371

## Accessories • Camera systems - adaptation

accessories optical, Adapter, 14x64x64mm, Aluminum



### Mechanical features

Adaption	OC53 - Tripod
Width	63.5 mm
Height	13.5 mm
Length	63.5 mm
Surface	teflon coated
Material	Aluminum

### Classification

ETIM 8	EC002024 Accessories/spare parts for command devices
--------	--

### More

IPF Product Group	914 accessories camera sensors
packaging dimensions	150 x 100 x 13 mm
gross weight	143 g
Customs tariff number	76169990
WEEE number	40951076
OzDS-compliant	Yes
POP-compliant	Yes
Reach-compliant	Yes
RoHS-compliant	Yes

**Dimensional drawing**

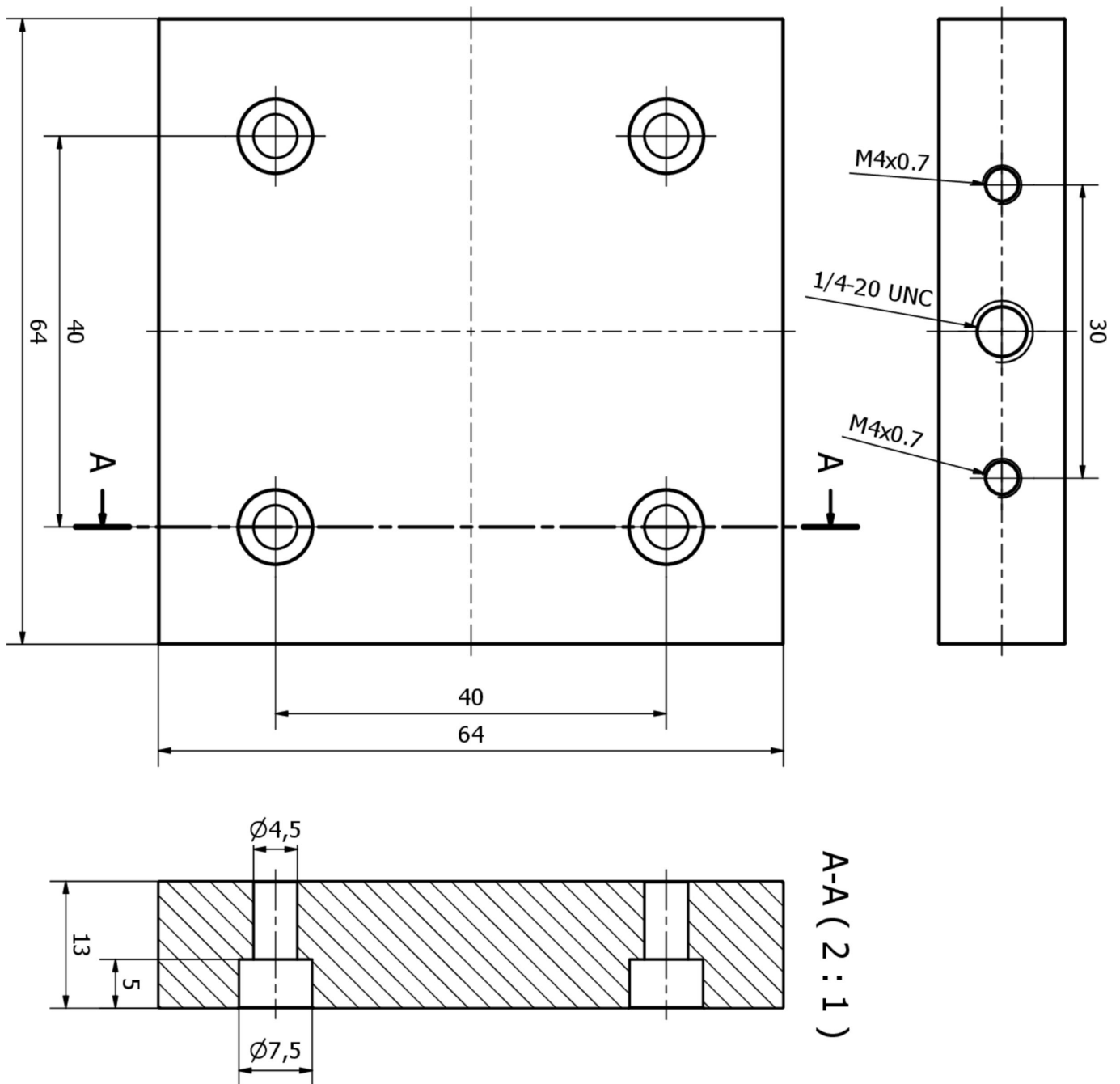

**Installation**

Mounting / installation may only be carried out by a qualified electrician!



**Disposal**

WEEE number according to § 6 para. 3  
ElektroG: 40951076

**Safety warnings**

**/** Before initial operation, please make sure to follow all safety instructions that may be provided in the product information.

**/** Never use these devices in applications where the safety of a person depends on their functionality.