

AO000579

Accessories • Mounting

accessories optical, tripod, 1300mm high, -30-60°C, Aluminum, 90°



Mounting aid for OC29

Mechanical features

Height	1300 mm
Mounting method	Screw mounting
Material	Aluminum
Angle	90 °
Ambient temperature	-30 - 60 °C

Other features

Version	Tripod
---------	--------

Classification

ETIM 8	EC002625 Mounting accessories (control cabinet)
--------	---

More

IPF Product Group	914 accessories camera sensors
packaging dimensions	480 x 120 x 90 mm
gross weight	907 g
Customs tariff number	96200010
WEEE number	40951076
Reach-compliant	Yes
RoHS-compliant	Yes

Dimensional drawing

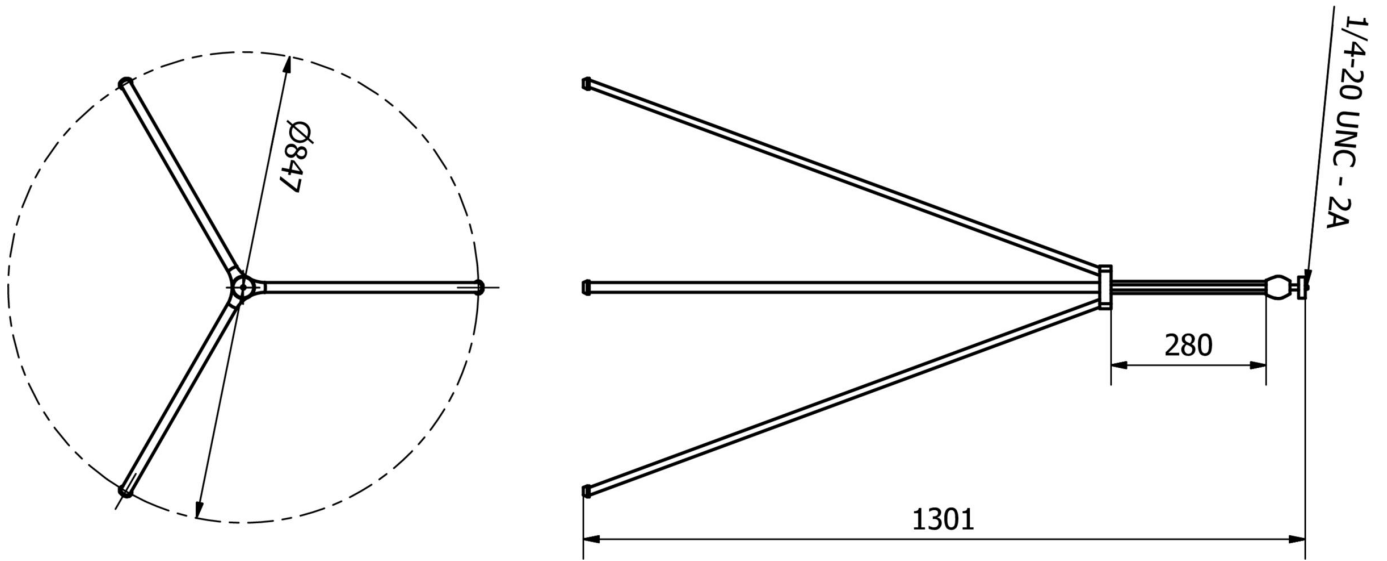

Installation

Mounting / installation may only be carried out by a qualified electrician!



Disposal

WEEE number according to § 6 para. 3
ElektroG: 40951076

Safety warnings

- / Before initial operation, please make sure to follow all safety instructions that may be provided in the product information.
- / Never use these devices in applications where the safety of a person depends on their functionality.