

A0000654

Accessories • Mounting

Accessories Optical, mounting bracket, 130x66x61,5mm, anodized aluminum

including Screw



for mounting ring lights Ø130mm and dark field lights EF750xxx

Mechanical features

Width	66 mm
Height	61.5 mm
Length	130 mm
Surface	Anodized
Material	Aluminum
Accessories for	Camera illumination

Other features

Version	Mounting bracket
---------	------------------

Classification

ETIM 8	EC002024 Accessories/spare parts for command devices
--------	--

More

IPF Product Group	914 accessories camera sensors
packaging dimensions	127 x 180 x 70 mm
gross weight	98 g
Customs tariff number	76169990
WEEE number	40951076
Reach-compliant	Yes
RoHS-compliant	Yes

Dimensional drawing

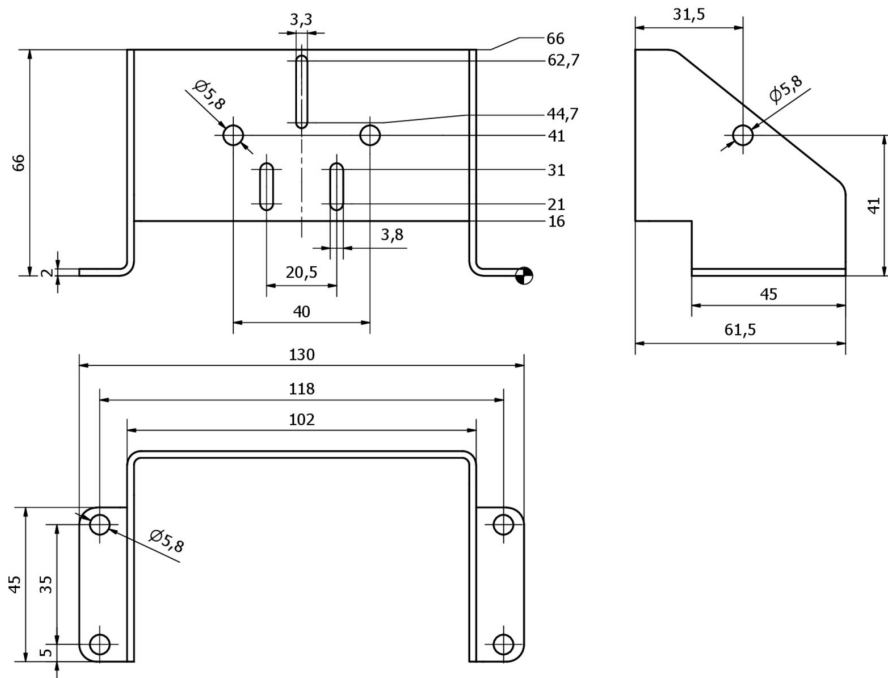

Installation

Mounting / installation may only be carried out by a qualified electrician!



Disposal

WEEE number according to § 6 para. 3 ElektroG: 40951076

Safety warnings

- / Before initial operation, please make sure to follow all safety instructions that may be provided in the product information.
- / Never use these devices in applications where the safety of a person depends on their functionality.