

# A0000669

## Accessories • Mounting

Accessories Optical, holder, plastic

including Hexagon socket screw



### coaxial mounting to the camera

For attaching the ER1A0X70 ring light to the OC53 camera with C-mount connection

#### Mechanical features

Width	32 mm
Height	65 mm
Length	110 mm
Material	Plastic

#### Other features

Version	Holder
---------	--------

#### Classification

ETIM 8
--------

#### More

IPF Product Group	914 accessories camera sensors
packaging dimensions	120 x 190 x 35 mm
gross weight	55 g
Customs tariff number	39269097
WEEE number	40951076
Reach-compliant	Yes
RoHS-compliant	Yes

**Dimensional drawing**

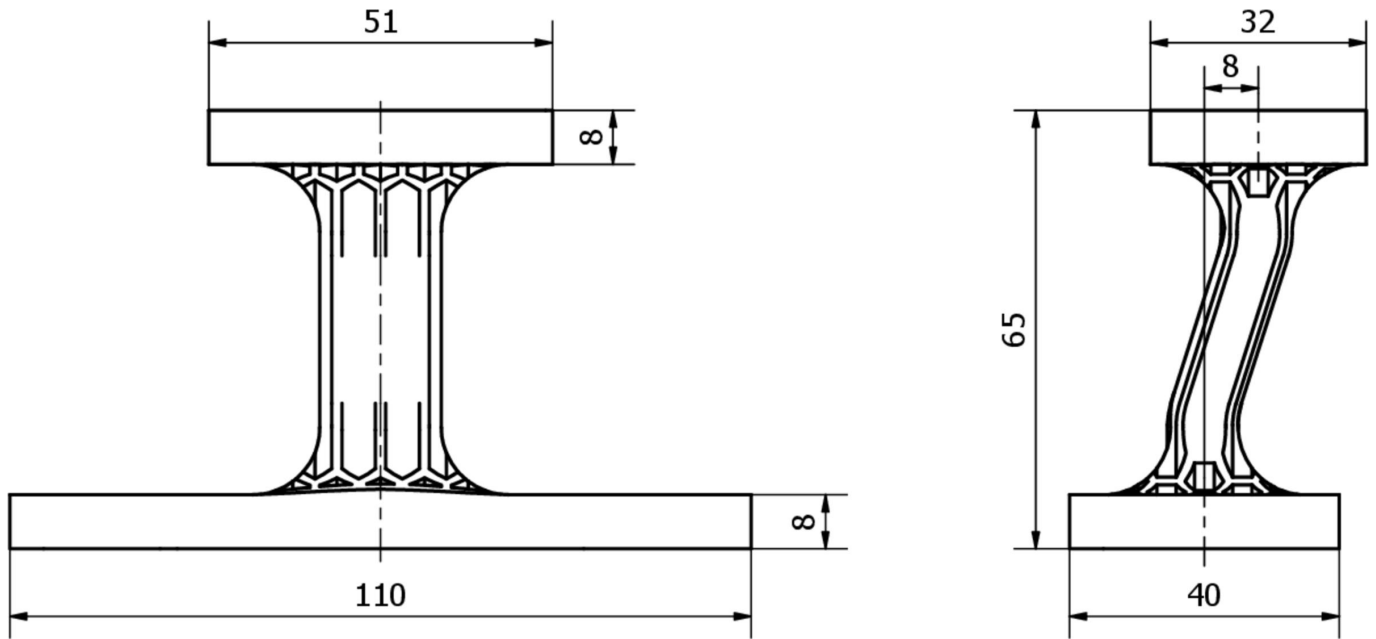

**Installation**

Mounting / installation may only be carried out by a qualified electrician!



**Disposal**

WEEE number according to § 6 para. 3  
ElektroG: 40951076

**Safety warnings**

- / Before initial operation, please make sure to follow all safety instructions that may be provided in the product information.
- / Never use these devices in applications where the safety of a person depends on their functionality.