

# AS000017

## Accessories • Mounting

Accessories Clamp bracket set, 124x69,5x12mm, stainless steel



for SMxx002x

### Mechanical features

Width	12 mm
Height	69.5 mm
Length	124 mm
Material	Stainless steel

### Other features

Features	partially with polyolefin coating
Version	Clamp holder

### Classification

ETIM 8	EC002024 Accessories/spare parts for command devices
--------	--

### More

IPF Product Group	900 accessories
packaging dimensions	150 x 100 x 25 mm
gross weight	94 g
Customs tariff number	73269098
WEEE number	40951076
POP-compliant	Yes
Reach-compliant	Yes
RoHS-compliant	Yes

**Dimensional drawing**

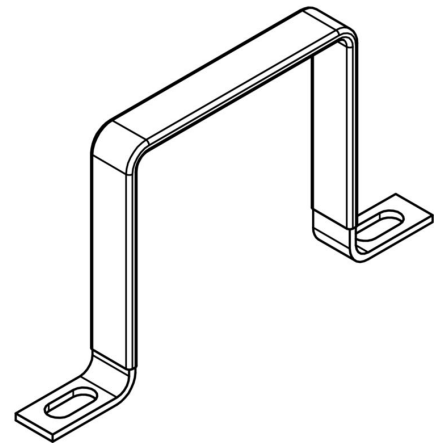
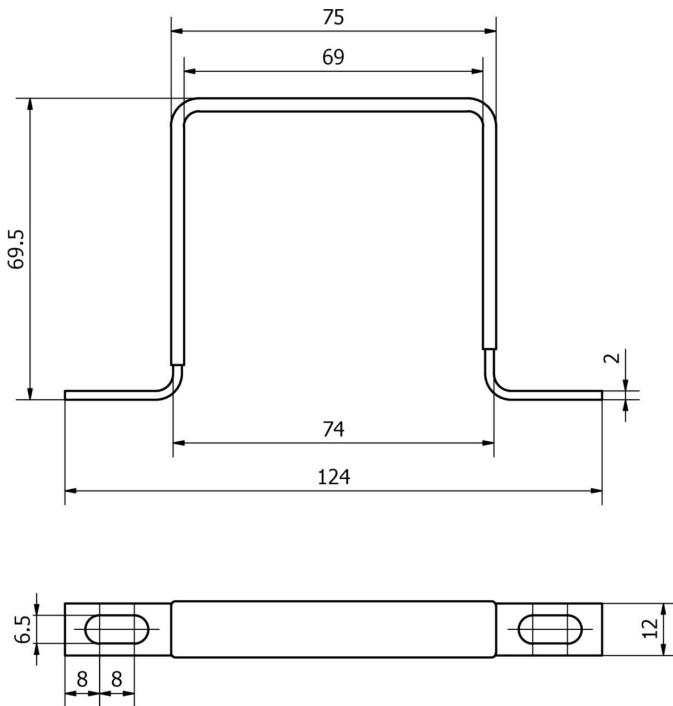

**Installation**

Mounting / installation may only be carried out by a qualified electrician!



**Disposal**

WEEE number according to § 6 para. 3  
ElektroG: 40951076

**Safety warnings**

- / Before initial operation, please make sure to follow all safety instructions that may be provided in the product information.
- / Never use these devices in applications where the safety of a person depends on their functionality.