

AV000037

Accessories • measuring wheel

accessories miscellaneous, Rubber with naps, 25mm wide, Aluminum



Mechanical features

Tightening torque	3 Nm
Width	25 mm
Diameter	159.15 mm
Shaft diameter A	6 mm
Surface	knurled
Material	Aluminum
Material of the coating	Plastic (NBR)
Ambient temperature	-10 - 50 °C

Classification

ETIM 8	EC002024 Accessories/spare parts for command devices
--------	--

More

IPF Product Group	900 accessories
packaging dimensions	170 x 170 x 35 mm
gross weight	290 g
Customs tariff number	76169990
WEEE number	40951076
OzDS-compliant	Yes
POP-compliant	Yes
Reach-compliant	Yes
RoHS-compliant	Yes

Dimensional drawing

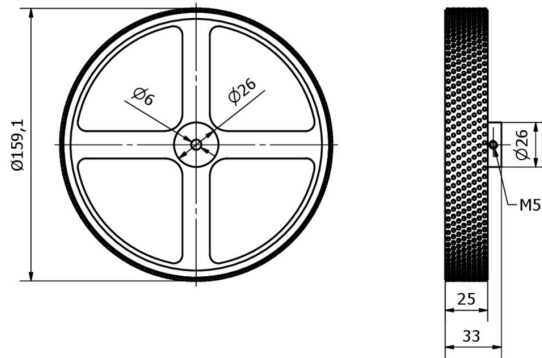

Installation

Mounting / installation may only be carried out by a qualified electrician!



Disposal

WEEE number according to § 6 para. 3
ElektroG: 40951076

Safety warnings

- / Before initial operation, please make sure to follow all safety instructions that may be provided in the product information.
- / Never use these devices in applications where the safety of a person depends on their functionality.