

# AV000137

## Accessories • Linear and angular measurement

accessories, Torque support, 7,7x65x51mm, Aluminum

including Spring washer, Screw

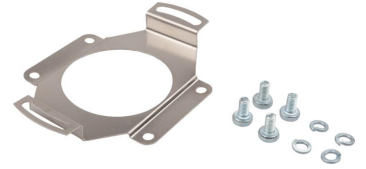

for fixing with screws

### Mechanical features

Width	51 mm
Height	7.7 mm
Length	65 mm
Mounting method	Screw mounting
Material	Aluminum

### Classification

ETIM 8	EC002625 Mounting accessories (control cabinet)
--------	---

### More

IPF Product Group	900 accessories
packaging dimensions	100 x 70 x 5 mm
gross weight	5 g
Customs tariff number	76169990
WEEE number	40951076
Reach-compliant	Yes
RoHS-compliant	Yes

**Dimensional drawing**

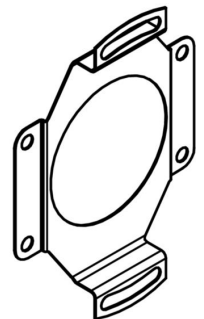
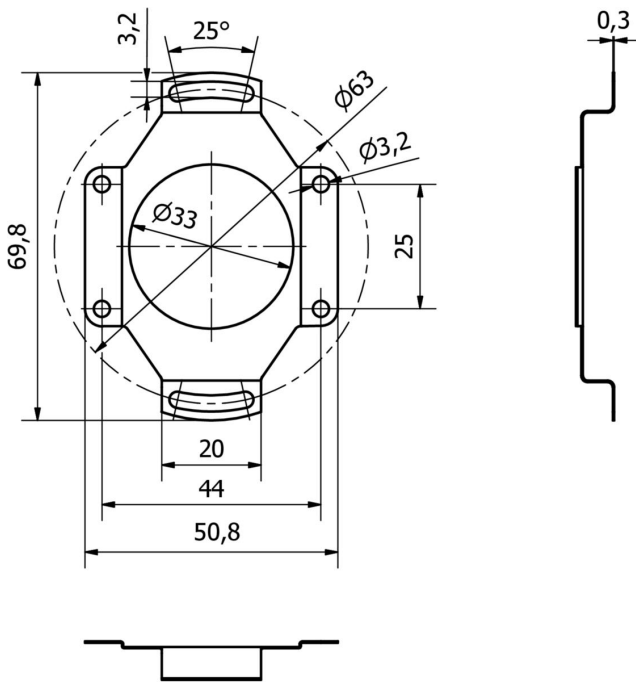

**Installation**

Mounting / installation may only be carried out by a qualified electrician!



**Disposal**

WEEE number according to § 6 para. 3  
ElektroG: 40951076

**Safety warnings**

- / Before initial operation, please make sure to follow all safety instructions that may be provided in the product information.
- / Never use these devices in applications where the safety of a person depends on their functionality.