

AY000159

Accessories • Installation - pipe installation system

Accessories sensor, mounting tube, Ø12mm 200long, aluminum anodized/anodized



This mounting system is suitable for mounting sensors anywhere. For the mounting tubes with a diameter of 12mm, which are available in lengths of 200 and 500mm, there are a variety of clamp holders with which the tubes can be securely fastened. The mounting clamp holder is equipped with an M6 inside thread. Both the mounting brackets and the universal mounting brackets with ball head can be attached to it. For the foot clamp holder AY000161 and the clamp holder AY000163, the magnetic AY000162 is also available, with which the mounting structure can be easily attached to a magnetic machine part.

Mechanical features

Diameter	12 mm
Length	200 mm
Surface	Anodized
Material	Aluminum

Other features

Version	Mounting tube
---------	---------------

Classification

ETIM 8	EC002024 Accessories/spare parts for command devices
--------	--

More

IPF Product Group	900 accessories
packaging dimensions	250 x 200 x 12 mm
gross weight	32 g
Customs tariff number	76090000
WEEE number	40951076
POP-compliant	Yes
Reach-compliant	Yes
RoHS-compliant	Yes

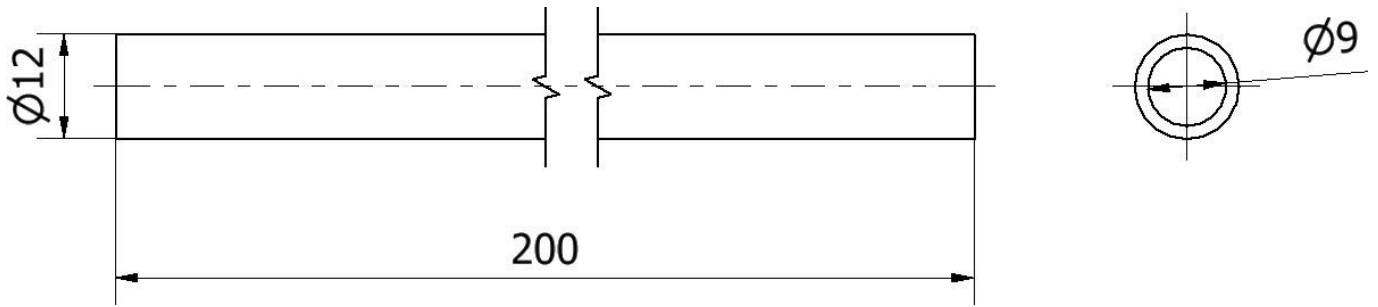
Dimensional drawing**Installation**

Mounting / installation may only be carried out by a qualified electrician!

**Disposal**

WEEE number according to § 6 para. 3
ElektroG: 40951076

Safety warnings

- / Before initial operation, please make sure to follow all safety instructions that may be provided in the product information.
- / Never use these devices in applications where the safety of a person depends on their functionality.