

FS926030

Accessories • conductive

Filling level sensor, conductive, 1" 1052long, G1", -10-100°C, connection to amplifier, terminals 3-pole, polyamide, ring POM+stainless steel 1.4571, IP65, probe 3x Ø4mm 1000long

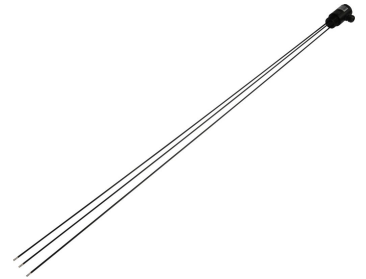

Filling level and level sensors operate according to different measuring principles. The selection of the sensor depends on the medium to be detected and the ambient conditions. The material flow in a vibratory bowl can be excellently queried with inductive filling level sensors whose pendulum is moved by the material in the pot. The detection of liquid or solid media is, for instance, possible with capacitive filling level sensor technology. These work according to the principle of the condensator, the medium changes the dielectricity between two electrodes. The resulting change is converted into a digital output signal. A further alternative for the detection of filling levels of conductive media is provided by conductive filling level relays. The resistance between reference and measuring electrode is determined. If a set threshold is exceeded, a relay output switches.

Electrical features

Number of probes	3
Type of switching function	Amplifier
Type of electrical connection	Clamped terminal connection
Type of switching output	Amplifier
Number of pins	3
Measurement principle	Conductive

Mechanical features

Type of process connection	G1 inch
Design	Round
Pressure resistance	10 bar
Diameter	40 mm
Probe diameter	4 mm
Thread length	15 mm
Height	52 mm
Length	1052 mm
Probe length	1000 mm
Medium temperature	-20 - 100 °C
Degree of protection (IP)	IP65
Active area material of sensor	Plastic (POM)
Housing material	Polyamide PA
Sensing element material	Stainless steel 1.4571
Thread dimension	1 inch
Ambient temperature	-10 - 100 °C

Classification

ETIM 8	EC001447 Level/level monitoring device
--------	--

More

IPF Product Group	350 filling level sensors (capacitive/conductive)
packaging dimensions	1170 x 70 x 50 mm
gross weight	498 g
Customs tariff number	85365019
WEEE number	40951076
Reach-compliant	Yes
RoHS-compliant	Yes

Connection

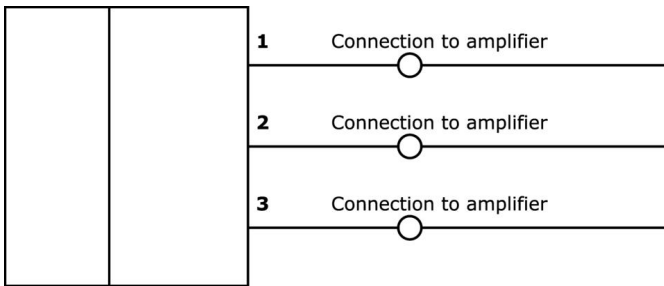

Dimensional drawing

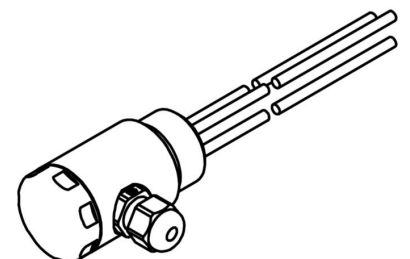
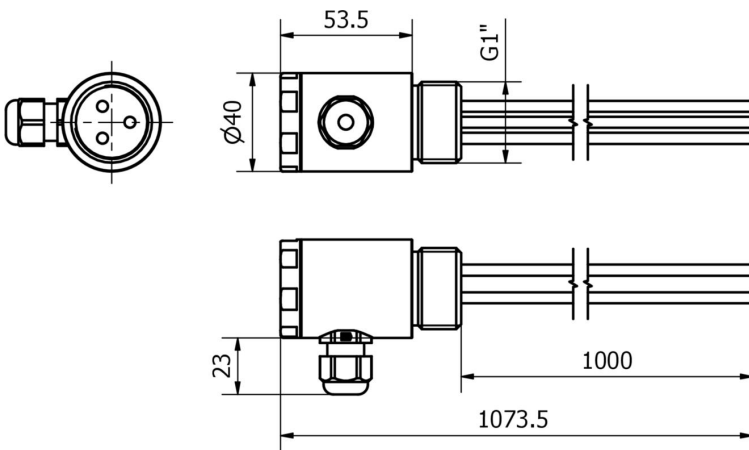

Extract accessories program**FV565900**

amplifier filling level, Conductive,
23x114x99mm, 2 Channels, 20-
253V DC, Clamp, IP20, Polyamide,
With LED display

FV565901

amplifier filling level, Conductive,
23x114x99mm, 2 Channels, 20-
253V DC, Clamp, IP20, Polyamide,
With LED display

You can find further accessories on our homepage

**Installation**

Mounting / installation may only be carried out by a qualified electrician!

**Disposal**

WEEE number according to § 6 para. 3
ElektroG: 40951076

Safety warnings

- / Before initial operation, please make sure to follow all safety instructions that may be provided in the product information.
- / Never use these devices in applications where the safety of a person depends on their functionality.