

FV565900

Filling level sensors • Conductive amplifier

amplifier filling level, Conductive, 23x114x99mm, 2 Channels, 20-253V DC, Clamp, IP20, Polyamide, With LED display



Filling level and level sensors operate according to different measuring principles. The selection of the sensor depends on the medium to be detected and the ambient conditions. The material flow in a vibratory bowl can be excellently queried with inductive filling level sensors whose pendulum is moved by the material in the pot. The detection of liquid or solid media is, for instance, possible with capacitive filling level sensor technology. These work according to the principle of the condensator, the medium changes the dielectricity between two electrodes. The resulting change is converted into a digital output signal. A further alternative for the detection of filling levels of conductive media is provided by conductive filling level relays. The resistance between reference and measuring electrode is determined. If a set threshold is exceeded, a relay output switches.

Electrical features

Number of channels	2
Number of contacts as change-over contact	2
Display	LED display
Type of electrical connection	Clamped terminal connection
Rated switching current	10000 mA
Power consumption	10 VA
Switching capacity	2500 VA
Switching voltage	250 V
Reverse polarity protection	Yes
Operating voltage (AC 50Hz)	20 - 253 V
Operating voltage (DC)	20 - 253 V
Galvanic separation between output to output	Yes
Galvanic isolation between supply voltage and all other current circuits	Yes
Measuring range Conductive	$\leq 200k\Omega$ or $\geq 5\mu S/cm$

Mechanical features

Design	Cuboid
Width	93.1 mm
Height	22.6 mm
Length	113.6 mm
Mounting method	Top hat rail
Degree of protection (IP)	IP20
Housing material	Polyamide PA
Ambient temperature	-40 - 70 °C

Other features

Version	Built-in device
---------	-----------------

Classification

ETIM 8	EC001485 Isolation amplifier
--------	------------------------------

More

IPF Product Group	350 filling level sensors (capacitive/conductive)
packaging dimensions	30 x 100 x 115 mm
gross weight	179 g
Customs tariff number	85365019
WEEE number	40951076
Reach-compliant	Yes
RoHS-compliant	Yes

Connection

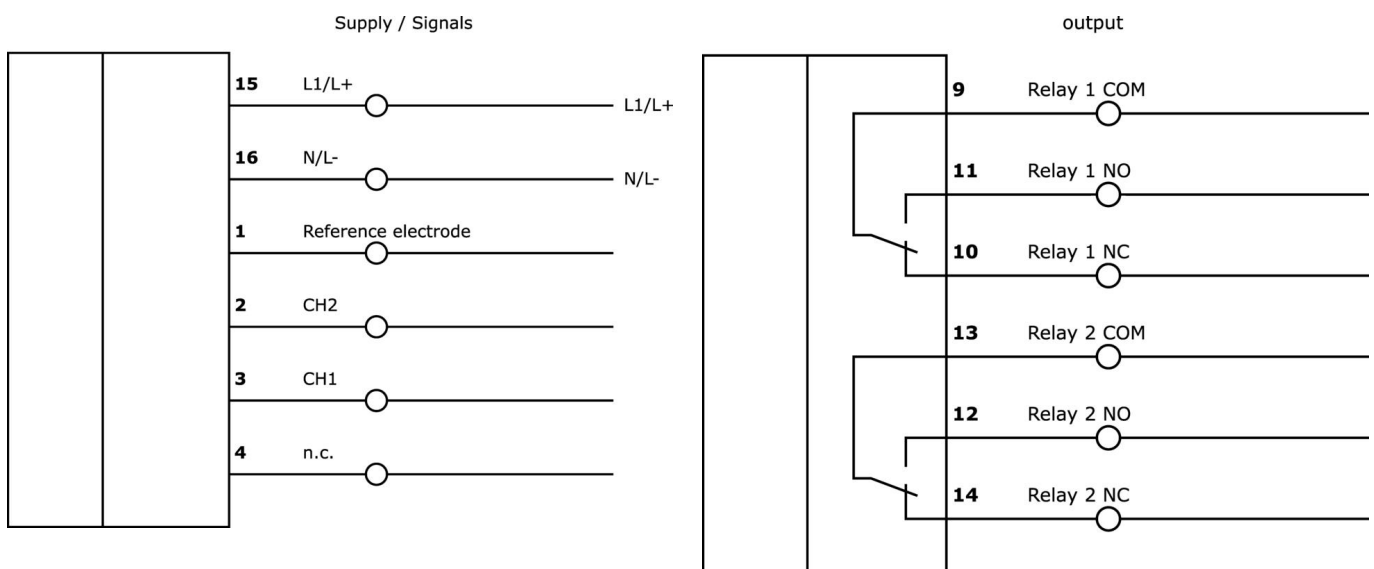

Dimensional drawing

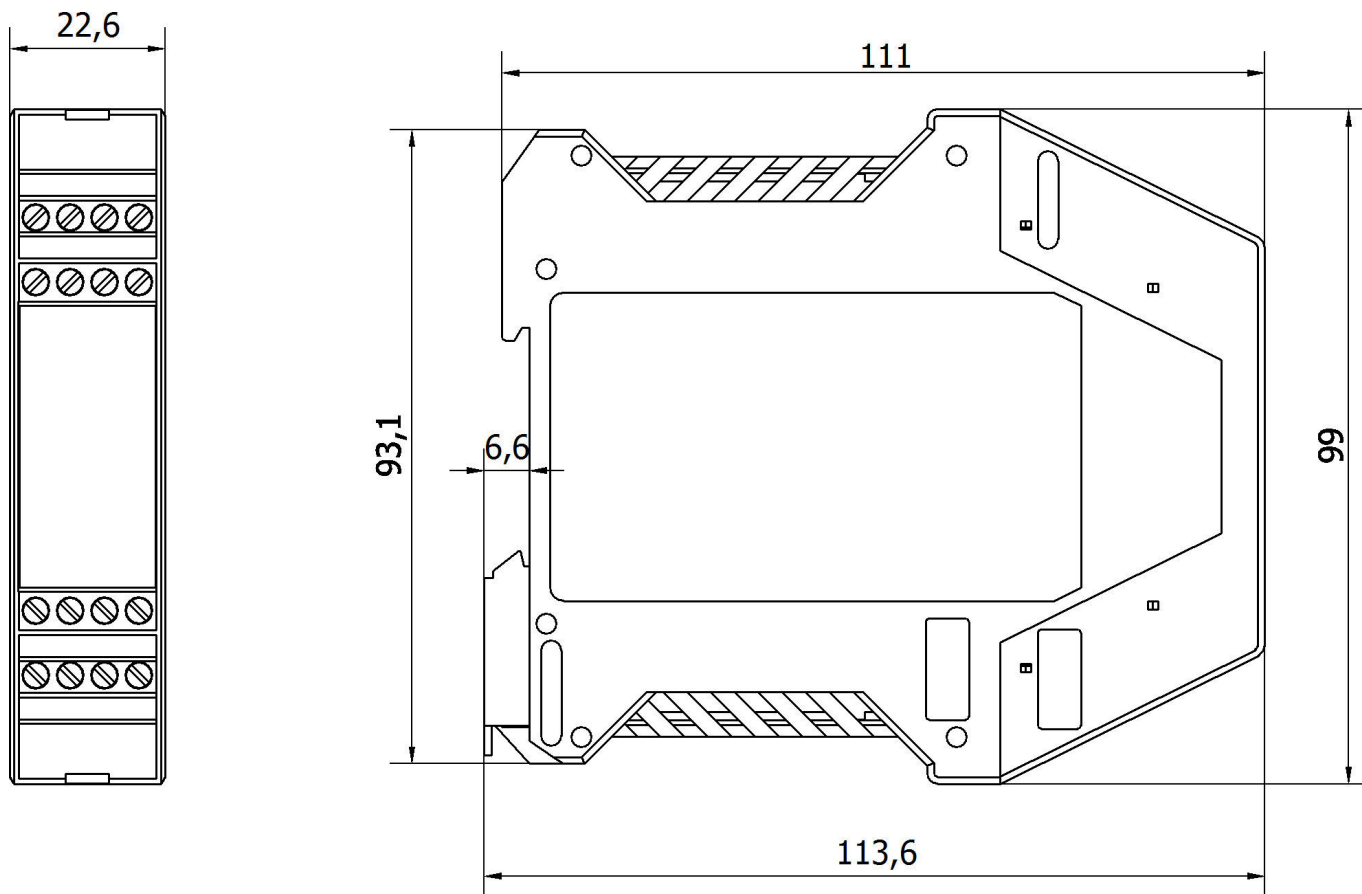

Extract accessories program

FS906000

Filling level sensor, conductive, 1/2" 552long, G 1/2", -40-150°C, connection to amplifier, terminals 1-pole, polyamide, ring POM+stainless steel 1.4571, IP65, probe 1x Ø4mm 500long

FS926030

Filling level sensor, conductive, 1" 1052long, G1", -10-100°C, connection to amplifier, terminals 3-pole, polyamide, ring POM+stainless steel 1.4571, IP65, probe 3x Ø4mm 1000long

NG400501



DC power supply, 1-phase, 125x114x40mm, 24-28V, 5A, 90-264V AC 50Hz, 90-264V AC 60Hz, 127-370V DC, screw connection, IP20, aluminum, stabilized, pulsed output voltage

You can find further accessories on our homepage



Installation

Mounting / installation may only be carried out by a qualified electrician!



Disposal

WEEE number according to § 6 para. 3 ElektroG: 40951076

Safety warnings

/ Before initial operation, please make sure to follow all safety instructions that may be provided in the product information.

/ Never use these devices in applications where the safety of a person depends on their functionality.