

LS102911

Fiber optic sensors • Fiber optic glass barrier

fiber optic barrier, 1m, head: Stainless steel 37long Ø4 Ø8, Light exit Axial, conductor: Glassfiber+Stainless steel, end piece: M12x1 Brass, -40-300°C



Fiber optics in combination with the appropriate fiber optic amplifier function as contactless and wear-free position switches that can also be used in harsh environmental conditions. They detect objects independent of their characteristics (e.g., shape, color, surface structure, material). Because the ends and heads of the fiber optics have small dimensions and the fiber optics are flexible, very elegant solutions can be created for detecting objects in places that are difficult to access. Fiber optics can be used without special precautions in potentially explosive areas and in zones with electrical and/or magnetic fields (high-voltage installations, electrical welding equipment) as their function is not thereby affected. Fiber optics are available in versions for implementing the function as through-beam sensor or diffuse reflection sensor.

Electrical features

Bending section of the sensing head	0 mm
Bending angle of the sensing head	90 °
Short-circuit protection	No
Sensing head length	37 mm
Reverse polarity protection	No

Mechanical features

Type of fiber	Multi
Design	Cylinder plain
Sensing head diameter 1	4
Sensing head diameter 2	8
Fiber diameter	2.3 mm
End piece diameter	14 mm
Fiber optic cable diameter, receiver end	6.7
Fiber optic cable diameter, transmitter end	6.7
Sensing head diameter	4 mm
Number of fibers	2
End piece thread pitch	1 mm
Length	1000 mm
End piece length	36 mm
Sheathing material	Stainless steel
End piece material	Brass
Fiber optics core material	Glass
Sensing head material	Stainless steel
Ejection control	Yes
Strong vibration / motion	Yes
Design of the fiber optic connection	screw fitting M12
Thread dimension of the end piece	M12
Ambient temperature	-40 - 300 °C

Optical features

Light exit	axial
------------	-------

Other features

Feeding technology	Yes
ardTE00_Anwendungen	Stanzwerkzeuge starke Verschmutzung

Classification

ETIM 8	EC002651 Fiber optic sensor/amplifier
--------	---------------------------------------

More

IPF Product Group	150 glass fibers
packaging dimensions	149 x 124 x 28 mm
gross weight	210 g
Customs tariff number	90011090
WEEE number	40951076
Reach-compliant	Yes
RoHS-compliant	Yes

Dimensional drawing

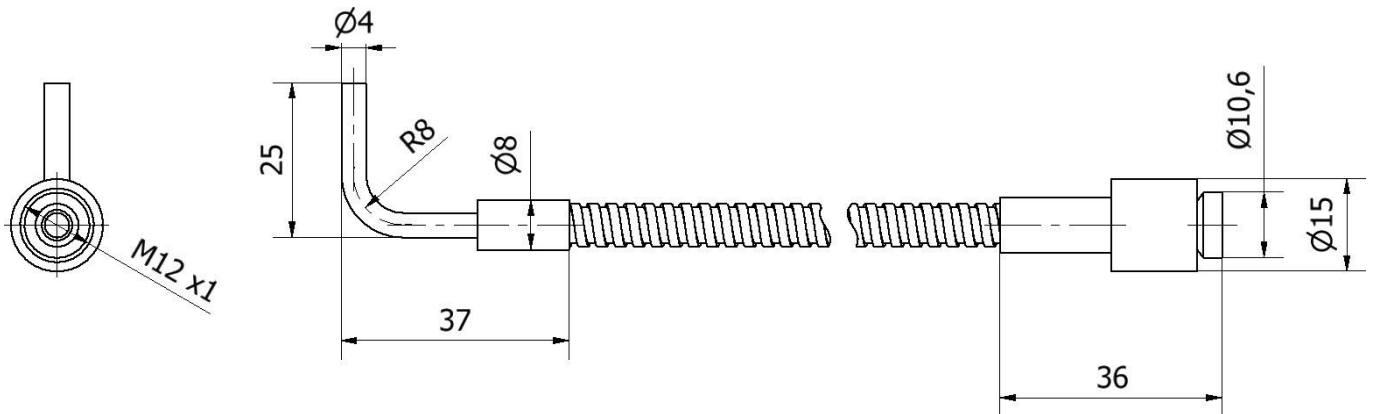

Installation

Mounting / installation may only be carried out by a qualified electrician!



Disposal

WEEE number according to § 6 para. 3
ElektroG: 40951076

Safety warnings

- / Before initial operation, please make sure to follow all safety instructions that may be provided in the product information.
- / Never use these devices in applications where the safety of a person depends on their functionality.