

## MW100105

### Linear and angular measurement • magnetic

linear measurement sensor, magnetic, 37x25x10mm, Relative, 100µm, Sn: 0.1-2, 5V, TTL level, Cable 4pin 2m PUR (Polyurethane), IP67, Plastic, 25m/s

including Spring washer

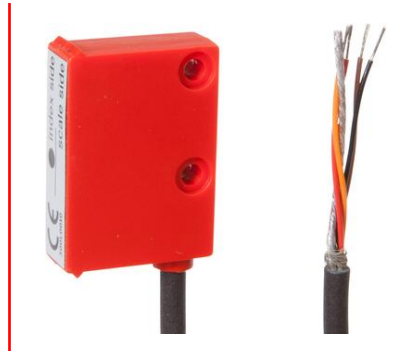

For length measurement, rotational speed or angle measurement, magnetic measuring systems are used. These systems operate in a way that the sensor moves without contact over a flexible magnetic tape, or it is situated above the rotating magnetized measuring wheel. The magnetic tape is applied to a 0.3mm thick steel strip and is located on the circumference of the various measuring wheels. The magnetization is carried out with defined pole pitches. By scanning of the magnetic poles an analog signal is generated, which is converted into digital square wave signals that can be processed by a downstream electronics and, if necessary, be displayed. The sensor detects the pitch of the strip and converts the information into a high-resolution path or rotation information. To read out the magnetic lines no direct contact is required. Magnetic sensors are insensitive to dirt, oils and moisture and relatively stable at shock and vibration. For users, this opens up a wide field of applications, e.g. for plants and systems in the timber industry, at linear axes, in outdoor areas or with machine tools.

#### Electrical features

Resolution	0.1 mm
Type of electrical connection	Cable
Type of switching output	TTL level
Operating principle	Relative
No-load current	20 mA
Number of pins	4
Reverse polarity protection	Yes
Operating voltage (DC)	5 V
Measuring range	0,1 - 2 mm

**Mechanical features**

Width	10 mm
Height	37 mm
Cable length	2 m
Storage temperature	-30 - 80 °C
Length	25 mm
Max. traverse speed	25 m/s
Shock resistance, acceleration	50 g
Shock resistance, pulse time	11 ms
Degree of protection (IP)	IP67
Vibration resistance, acceleration	10.2 g
Housing material	Plastic
Material of cable sheath	Plastic (PUR)
Vibration resistance Frequency	5 - 150 Hz
Ambient temperature	-10 - 70 °C
Line diameter	4.4 mm

**Other features**

Relative air humidity (non-condensing)	0 - 100 %
--	-----------

**Classification**

ETIM 8	EC001852 Displacement sensor
--------	------------------------------

**More**

IPF Product Group	235 magnetic linear measurement systems
packaging dimensions	149 x 124 x 28 mm
gross weight	80 g
Customs tariff number	90318020
WEEE number	40951076
Reach-compliant	Yes
RoHS-compliant	Yes

**Connection**

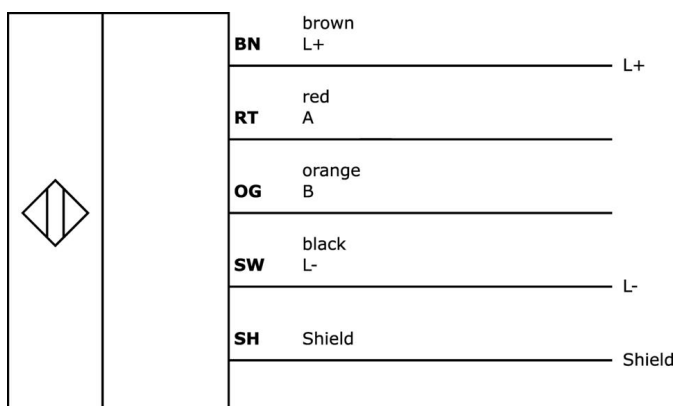

**Dimensional drawing**

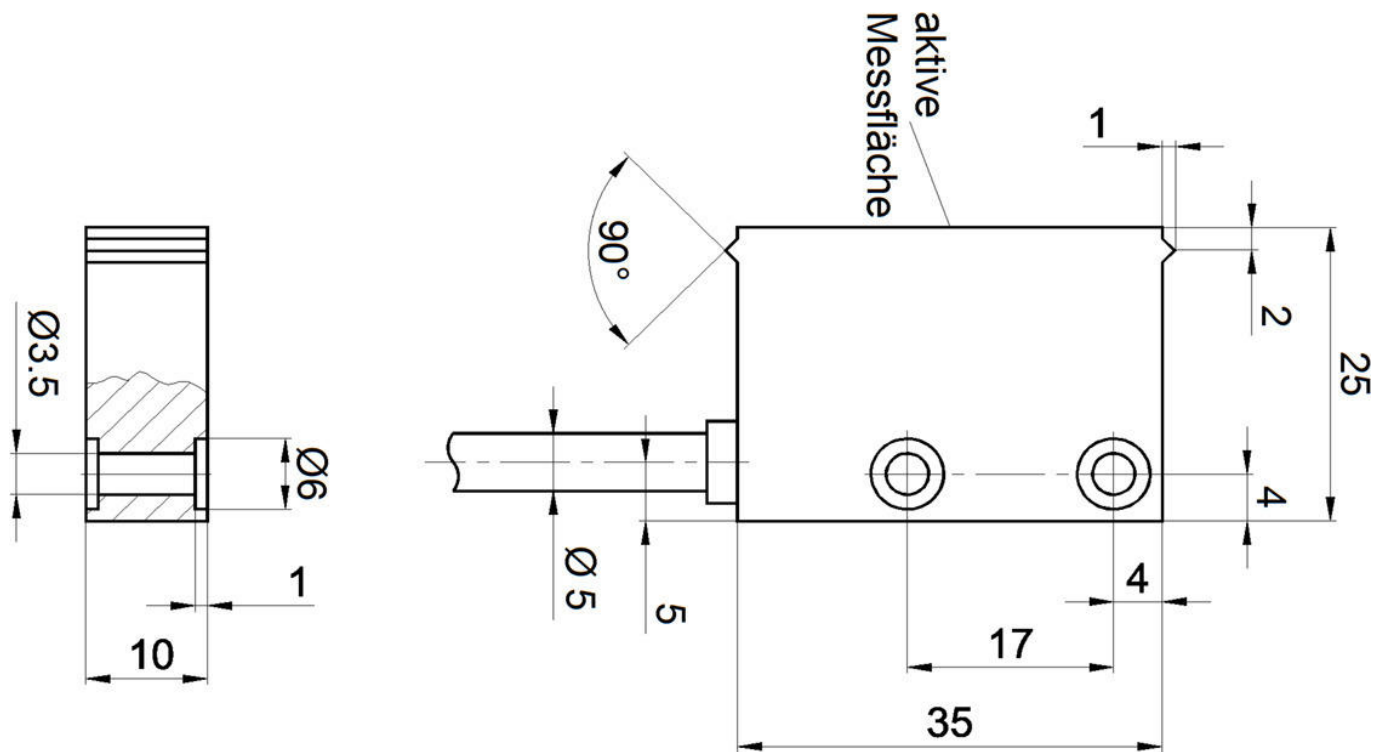

**Extract accessories program**

**AY000141**



Plastic sheath,  $\varnothing 17$ mm, Inner diameter 10mm, -40-250°C, Glass fiber with silicone rubber, Short-term resistance to weld spatter 1200°C, Tensile strength 400N, Flexible, Flame retardant, yard good

**AM000051**



accessories magnetic, Magnet ring,  $\varnothing 50$ mm, Hole diameter 9, Pin length 3.2mm, 64pin, Aluminum

**AM000055**

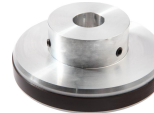

accessories magnetic, Magnet ring,  $\varnothing 102$ mm, Hole diameter 20, Pin length 3.2mm, 100pin, Aluminum

**AM000049**



accessories magnetic, magnetic strip, Width 10mm, pole length 3.2mm, resolution 0.1mm, Plastic+Stainless steel, yard good

You can find further accessories on our homepage



**Installation**

Mounting / installation may only be carried out by a qualified electrician!



**Disposal**

WEEE number according to § 6 para. 3 ElektroG: 40951076

**Safety warnings**

/ Before initial operation, please make sure to follow all safety instructions that may be provided in the product information.

/ Never use these devices in applications where the safety of a person depends on their functionality.