

MW991424

Linear and angular measurement • magnetic

Displacement sensor, magnetic, 15x27x7.8mm, relative, 10µm, Sn: 0.1-2, cable tail with plug connector 6-pin 3m PVC, IP67, aluminum, 5m/s

including Spring washer



For length measurement, rotational speed or angle measurement, magnetic measuring systems are used. These systems operate in a way that the sensor moves without contact over a flexible magnetic tape, or it is situated above the rotating magnetized measuring wheel. The magnetic tape is applied to a 0.3mm thick steel strip and is located on the circumference of the various measuring wheels. The magnetization is carried out with defined pole pitches. By scanning of the magnetic poles an analog signal is generated, which is converted into digital square wave signals that can be processed by a downstream electronics and, if necessary, be displayed. The sensor detects the pitch of the strip and converts the information into a high-resolution path or rotation information. To read out the magnetic lines no direct contact is required. Magnetic sensors are insensitive to dirt, oils and moisture and relatively stable at shock and vibration. For users, this opens up a wide field of applications, e.g. for plants and systems in the timber industry, at linear axes, in outdoor areas or with machine tools.

Electrical features

Resolution	0.01 mm
Type of electrical connection	Cable connector
Operating principle	Relative
Number of pins	6
Measuring range	0,1 - 2 mm

Mechanical features

Width	7.8 mm
Height	15 mm
Cable length	3 m
Storage temperature	-20 - 70 °C
Length	26.7 mm
Max. traverse speed	5 m/s
Shock resistance, acceleration	204 g
Shock resistance, pulse time	11 ms
Degree of protection (IP)	IP67
Vibration resistance, acceleration	20.4 g
Housing material	Aluminum
Material of cable sheath	Plastic (PVC)
Vibration resistance Frequency	50 - 2000 Hz
Ambient temperature	60 °C
Line diameter	5 mm

Other features

Relative air humidity (non-condensing)	0 - 100 %
--	-----------

Classification

ETIM 8	EC001852 Displacement sensor
--------	------------------------------

More

IPF Product Group	235 magnetic linear measurement systems
packaging dimensions	149 x 124 x 28 mm
gross weight	160 g
Customs tariff number	90318020
WEEE number	40951076
Reach-compliant	Yes
RoHS-compliant	Yes

Connection

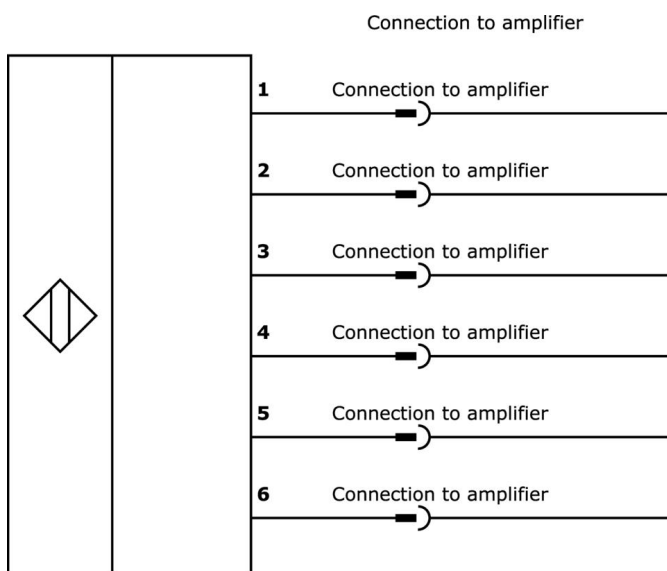

Extract accessories program

AY000141



Plastic sheath, Ø17mm, Inner diameter 10mm, -40-250°C, Glass fiber with silicone rubber, Short-term resistance to weld spatter 1200°C, Tensile strength 400N, Flexible, Flame retardant, yard good

AM000059



accessories magnetic, magnetic strip, Width 10mm, pole length 5mm, resolution 0.01mm, Plastic+Stainless steel, yard good

You can find further accessories on our homepage



Installation

Mounting / installation may only be carried out by a qualified electrician!



Disposal

WEEE number according to § 6 para. 3 ElektroG: 40951076

Safety warnings

- / Before initial operation, please make sure to follow all safety instructions that may be provided in the product information.
- / Never use these devices in applications where the safety of a person depends on their functionality.