

## OC539H21

### Camera systems • Process monitoring

Sensor optical, camera, color, 113x50x53mm, CCD(1/3"), 1280x960, focal distance variable, 5x PNP programmable/configurable, M12-connector 12pin, IP67, aluminum powder-coated+PMMA, C-mount, integrated flash controller, with Profinet



Camera sensors are used to simultaneously check various properties of objects (e.g., completeness, dimensional accuracy, position, damages, labeling). This takes place independent of the component position virtually in real time. Camera sensors are image processing systems that combine image sensor and image processing computer with image processing software in a metal housing. Depending on the version, lens and illumination unit are also integrated in the housing or must be additionally mounted. The camera sensors are set using an intuitive software program. On the device, object-specific check programs can be stored that contain the respective feature checks. These programs can be activated depending on the object that is to be inspected. The rugged housing design makes possible use under harsh environmental conditions.

#### Electrical features

Number of digital outputs	5
Number of digital inputs	5
Number of switching outputs	5
Type of switching function	Programmable/configurable
Type of electrical connection	Connector M12
Type of switching output	PNP
Rated switching current	100 mA
Property picture system	Color
Setting procedure	Application software
Error image memory	8
Short-circuit protection	Yes
No-load current	208 mA
Power consumption	5 VA
Number of pins	12
Reverse polarity protection	Yes
Type of plug-in contact, communication interface	Female (socket)
Type of plug-in connection, communication interface	Connector M12
Number of pins of interface connection	4
Supported communication interface	Ethernet   Profinet
Operating voltage (DC)	18 - 30 V
For interchangeable lens (C-mount)	Yes
Integrated flash controller for external illumination	Yes
ardSOCA_ElektrischerAnschluss	M12 12-pin plug connector
ardSOCA_Betriebsspannung	18-30VDC

**Mechanical features**

Width	53 mm
Height	113 mm
Length	50 mm
Surface	With powder coating
Degree of protection (IP)	IP67
Active area material of sensor	Plastic (PMMA)
Housing material	Aluminum
Ambient temperature	5 - 55 °C
ardSOCA_Abmessungen	50x53x113mm

**Optical features**

Resolution of image recorder	1280x960 px
Image recorder	CCD(1/3")
Dimensional accuracy	Yes
Measuring time for high resolution	31 fps
Object evaluation regardless of position	Yes
Pick and place	Yes
For geometry	distance   count edges   circle detection   point position determining   angle measurement
For part location	on edges   on contours   at text lines   on circles
For feature comparison	color arrangement   color identification   size of area   count surfaces   compare contours   count contour points   compare pattern

**Other features**

Relative air humidity (non-condensing)	0 - 90 %
Shock resistance in acc. with EN 60068-2-27	Yes
Vibration resistance in acc. with IEC 60068-2-6 / IEC 60068-2-64	Yes

**Classification**

ETIM 8	EC001511 Camera for surveillance system
--------	---

**More**

IPF Product Group	715 camera sensors
packaging dimensions	200 x 140 x 150 mm
gross weight	547 g
Customs tariff number	90314990
WEEE number	40951076
OzDS-compliant	Yes
POP-compliant	Yes
Reach-compliant	Yes
RoHS-compliant	Yes

**Connection**

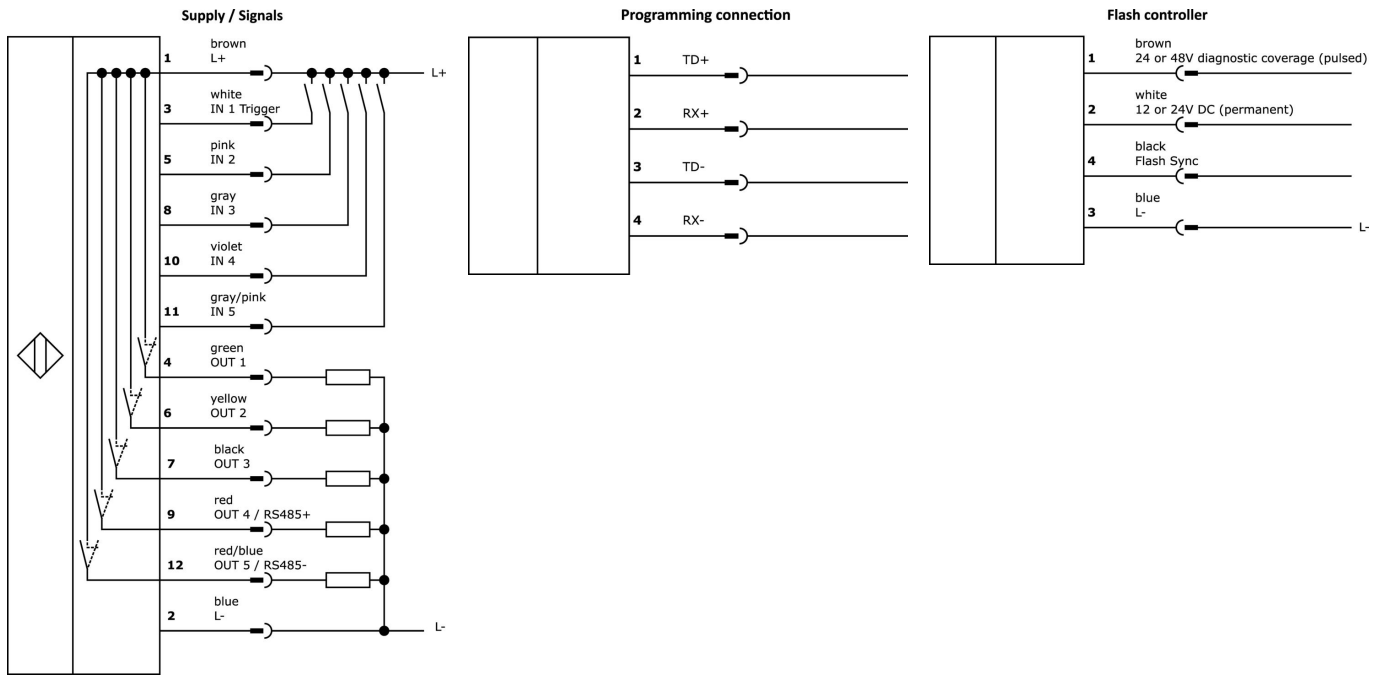

**Dimensional drawing**

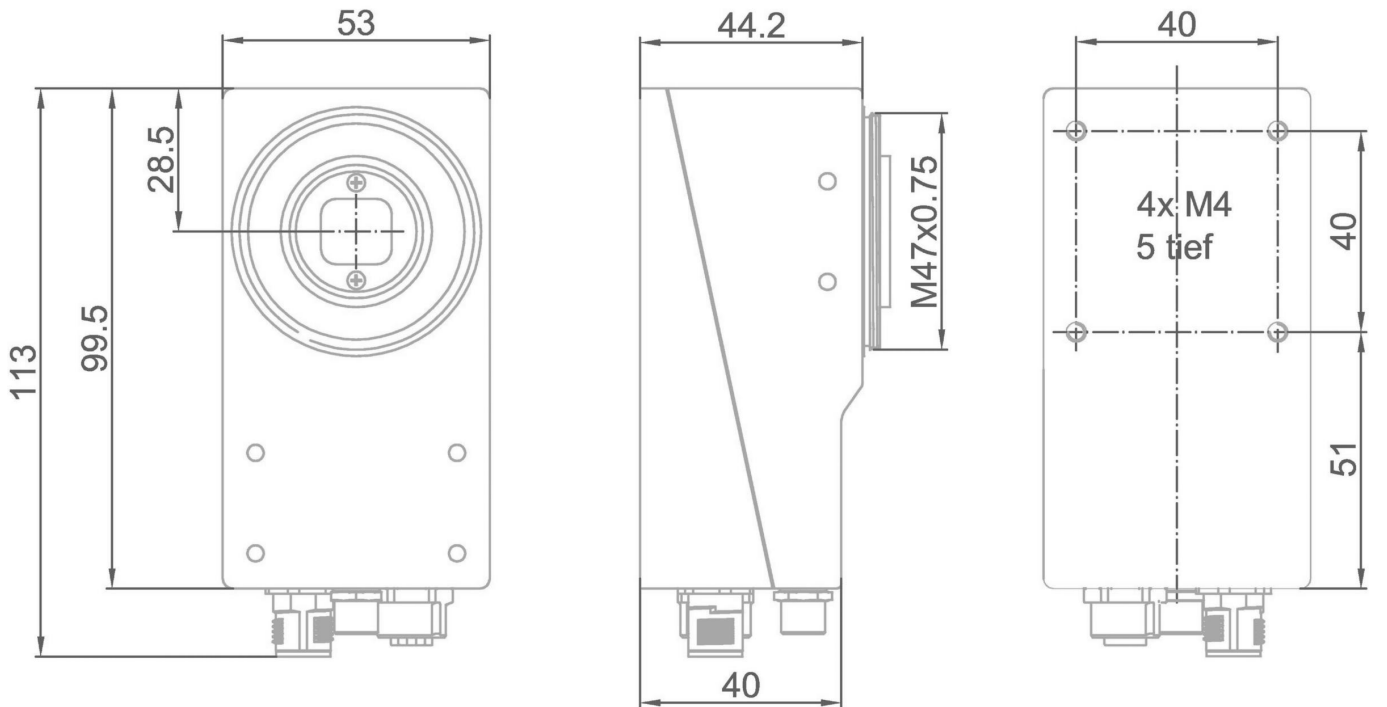

**Extract accessories program**

**EF750170**



LED dark field light,  
130x141x12mm, inner diameter  
75mm, white light, 6W, 5000K, 22-  
26V DC, M8 connector 4-pin, IP54,  
aluminum+PMMA

**EF750670**



LED dark field light,  
130x141x12mm, inner diameter  
75mm, blue light, 6W, 465nm, 22-  
26V DC, M8 connector 4-pin, IP54,  
aluminum+PMMA

**AO000523**



accessories optical, Interference /  
polarizing filter, 12x57x58mm,  
Other+Acrylic glass

**EE500170**



LED dome light, 100x100x52 mm,  
white light, 6W, 5000K, 23-25V  
DC, M8 connector 4-pin, IP20,  
aluminum

**EE500770**



LED dome light, 100x100x52 mm,  
red light, 3W, 625 nm, 23-25V DC,  
M8 connector 4-pin, IP20,  
aluminum

**ED1E0770**



LED transmitted light,  
150x120x12mm, red light  
unpolarized, 9W, 625nm, 24V DC,  
M8 connector 4-pin, IP54,  
aluminum+PMMA

**ED1E0170**



LED transmitted light,  
150x120x12mm, white light, 11W,  
5000K, 24V DC, M8 connector 4-  
pin, IP54, aluminum+PMMA

**AO000319**



LED line light, camera, 14x100mm,  
infrared light, 3.6W, 10-30V DC,  
M5 connector, IP50,  
aluminum+plastic

**AO98E124**



LED line light, camera,  
30x60x497mm, white light, 21.  
6W, 5000K, 24V, M8 connector 3-  
pin, IP40, aluminum+acrylic glass

You can find further accessories on our homepage



**Installation**

Mounting / installation may only be carried  
out by a qualified electrician!



**Disposal**

WEEE number according to § 6 para. 3  
ElektroG: 40951076

**Safety warnings**

/ Before initial operation, please make sure to follow all safety instructions that may be provided in the product information.

/ Never use these devices in applications where the safety of a person depends on their functionality.

/ Any software, drivers or IODD files that may be required to operate your device can be downloaded free of charge from our homepage: [www.ipf-electronic.com](http://www.ipf-electronic.com)