

OF659195

Optical sensors • Color sensors

sensor optical, color, 82x65x65mm, White light, True color, Sn: 50-500, 22-26V DC, 5x PNP/NPN Push-pull, Connector M9 8pin, IP64, Aluminum Anodised+Glass, $\Delta E \geq 0.5$, 40kHz, 31 colors



The functioning of the color sensors is based on the evaluation of the red, green and blue components of the light reflected by the objects to be measured, or from the emitted radiation of the 'self-luminous' object (for example, LEDs, automobile tail lights, halogen lamps, fluorescent lamps, etc.). For this purpose, a so-called 3-fold receiver is integrated in the unit next to an on / off switchable white light or UV-light. This receiver works according to the True Color principle. This means that the evaluation of the light hitting the receiver is similar to the color perception of the human eye. This is a prerequisite for the reliable differentiation of objects or luminous objects by their color and brightness. For testing fluorescent materials the use of sensors with UV-light source is recommended. The use under adverse environmental conditions is possible through the use of additional fiber optics. The interaction between a precise detection and a high switching frequency distinguishes the devices. Thus, they are an ideal tool for process and quality control.

Electrical features

Number of digital inputs	1
Number of switching outputs	5
Display	LED display
Type of switching function	Normally closed (n.o. for PNP) Normally closed (n.c. for NPN) - Adjustable
Type of electrical connection	Connector M9
Type of switching output	Push-pull
Rated switching current	100 mA
Setting procedure	Parameterization Teach-In
Pulse stretching	100 ms
No-load current	160 mA
Max. number of measurements for averaging	32768
Measurement frequency in flash mode	5000 Hz
Measurement frequency in constant light operation	35000 Hz
Measurement frequency in alternating light operation	20000 Hz
Number of pins	8
Switching frequency	40000 Hz
Protection class	III
Temperature drift	$\Delta X/\Delta T$; $\Delta Y/\Delta T$ typ. 0.2 digits/°C (< 0.01% / °C)
Reverse polarity protection	Yes
Type of plug-in contact, communication interface	Female (socket)
Type of plug-in connection, communication interface	Connector M5
Number of pins of interface connection	4
Selectable amplifier stages	8
Overload protection	Yes
Supported communication interface	RS232
Operating voltage (DC)	21,6 - 26,4 V
Measuring range	50 - 500 mm
Time function	Yes
Input function	Teach-in Trigger
Measurement frequency	5000 - 35000 Hz

Mechanical features

Design	Cuboid
Width	65 mm
Height	82 mm
Storage temperature	-20 - 85 °C
Length	65 mm
Surface	teflon coated
Degree of protection (IP)	IP64
Degree of protection (IP) of evaluation electronics	IP64
Degree of protection (IP), front side	IP67
Active area material of sensor	glass
Housing material	Aluminum
Number of colors	31
Ambient temperature	-20 - 55 °C

Optical features

Color distance	$\Delta E \geq 0.5$
Color spaces	X Y INT siM (Lab)
Light source	White light
Max. ambient light	5000 lx
Measuring method for color detection	Active tristimulus method
Nominal operating distance	200 mm
Constant light operation	Yes
True color	Yes
Alternating light operation	Yes
Number of colors	31
focus	200 mm
Light spot diameter at focal point	25 mm

Other features

Reference distance	200
--------------------	-----

Classification

ETIM 8	EC001817 Color probe
--------	----------------------

More

IPF Product Group	104 color sensors
packaging dimensions	210 x 138 x 95 mm
gross weight	452 g
Customs tariff number	85365019
WEEE number	40951076
POP-compliant	Yes
Reach-compliant	Yes
RoHS-compliant	Yes

Important notes

/ The value of the measurement frequency refers to the maximum of the slowest and the fastest operational mode.

Connection

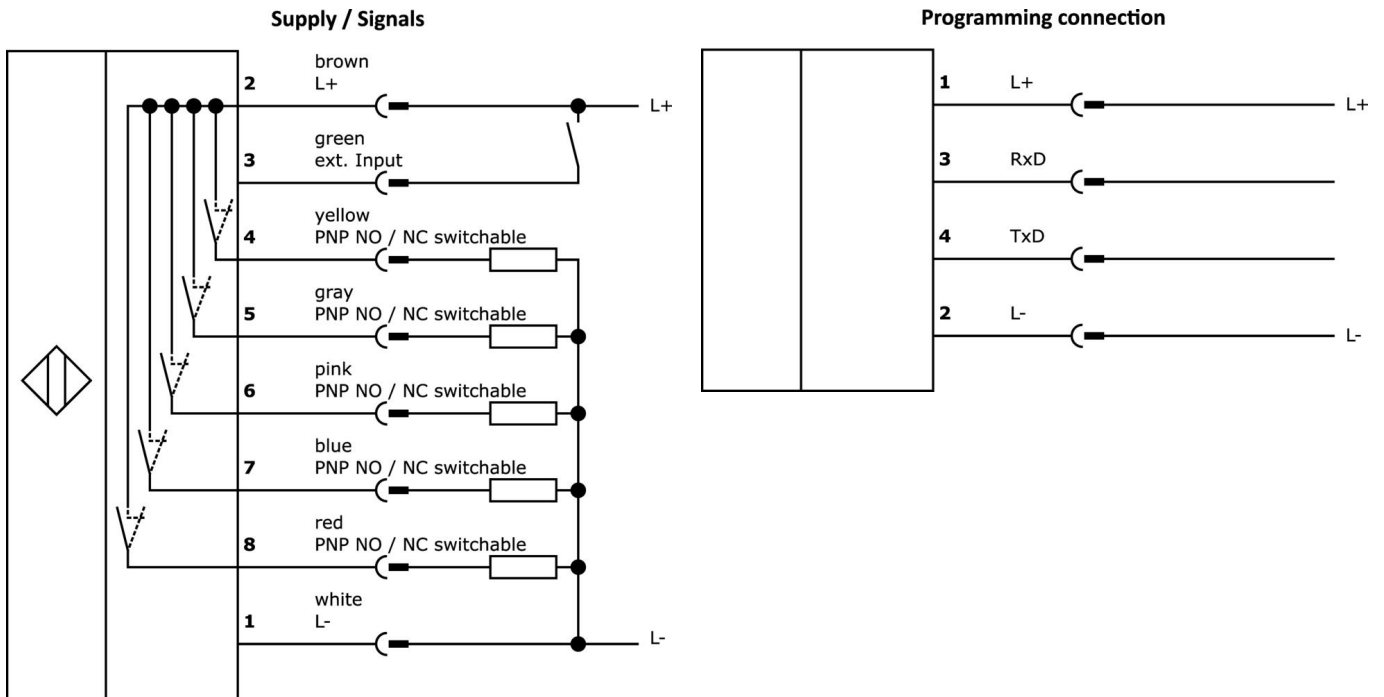

Extract accessories program

VK000053



Screw plug, M5, Plastic, Black

VK207F44



Connection cable RS232/Sub-D, 2m, M5 Male (connector) Straight, D-Sub Male (connector) 9pin Straight, PUR (Polyurethane)

VK207U40



Connection cable RS232/USB, 2m, M5 Male (connector) Angular, USB-A Male (connector) Straight, PUR (Polyurethane)

VK207U44



Connection cable RS232/USB, 2m, M5 Male (connector) Straight, USB-A Male (connector) Straight, PUR (Polyurethane)

VKSI0297



Connection cable RS232/Ethernet, 0.5m, M5 Male (connector) 4pin Straight, M12 Male (connector) 4pin Straight, D-coding, PUR (Polyurethane), Aluminum

VK207B41



Connection cable, 2m, M9 connector 8-pin angular, free cable end, 8x0.14mm², PUR (polyurethane), 125V, IP67, shielded, oils and cooling lubricants, welding area

VK207B45



Connection cable, 2m, M9 Male (connector) 8pin Straight, Free conductor end, 8x0.14mm², PUR (Polyurethane), 125V, IP67, Shielded, Oil and cooling lubricants, Welding area

You can find further accessories on our homepage



Installation

Mounting / installation may only be carried out by a qualified electrician!



Disposal

WEEE number according to § 6 para. 3 ElektroG: 40951076

Safety warnings

- /** Before initial operation, please make sure to follow all safety instructions that may be provided in the product information.
- /** Never use these devices in applications where the safety of a person depends on their functionality.
- /** Any software, drivers or IODD files that may be required to operate your device can be downloaded free of charge from our homepage: www.ipf-electronic.com