

OT180425

Optical sensors • Diffuse reflection sensors with intensity differentiation

sensor optical, diffuse-reflection sensor, M18x1 64long, Sn: 40-600, 10-35V DC, 2x PNP Anticoincidence, Connector M12 4pin, IP67, Brass Chrome-plated+Glass, 1kHz, Polarity free red light, Point, Manual adjustment

including Nut, Toothed washer



Optical sensors function contactlessly. They detect objects independent of their characteristics (e.g., shape, color, surface structure, material). The basic operating principle is based on the transmission and reception of light. There are three different versions: 1. The through-beam sensor consists of two separate devices, a transmitter and a receiver that are aligned with one another. If the light beam between the two devices is interrupted, the switching output integrated in the receiver changes its status. 2. With the retro-reflective sensor, the transmitter and receiver are located in one device. The emitted light beam is reflected back to the receiver by a reflector that is to be mounted opposite the device. As soon as the light beam is interrupted, the switching output integrated in the device changes its status. 3. With the diffuse reflection sensor, the transmitter and receiver are in one device. The emitted light beam is reflected by the object that is to be detected. As soon as the receiver detects the reflected light, the switching output integrated in the device changes its status.

Electrical features

Response/decay time	0.5 ms
Number of switching outputs	2
Display	LED display
Type of switching function	Exclusive-OR
Type of electrical connection	Connector M12
Type of switching output	PNP
Rated switching current	200 mA
Readiness delay	60 ms
Setting procedure	Manual adjustment
Relative hysteresis	10 %
Short-circuit protection	Yes
No-load current	20 mA
Number of pins	4
Switching distance	40 - 600 mm
Switching frequency	1000 Hz
Protection class	III
Voltage drop	2 V
Clock frequency of the transmitter	15 kHz
Scanning function	Light-/dark-on mode
Reverse polarity protection	Yes
Decay time	0.5 ms
Operating voltage (DC)	10 - 35 V

Mechanical features

Design	Cylinder, screw-thread
Thread length	42 mm
Thread pitch	1 mm
Length	63.5 mm
Maximum tightening torque	20 Nm
Surface	Chrome-plated
Degree of protection (IP)	IP67
Active area material of sensor	glass
Housing material	Brass
Thread dimension	M18
Ambient temperature	-25 - 55 °C

Optical features

Light source	Polarity free red light
Light exit	axial
Light beam form	Point
Wavelength of the sensor	660 nm

Other features

Feeding technology	Yes
Reference medium / object	Material with 90% reflectivity

Classification

ETIM 8	EC001821 Light sensor energetic
--------	---------------------------------

More

IPF Product Group	100 optical sensors
packaging dimensions	210 x 185 x 19 mm
gross weight	67 g
Customs tariff number	85365019
WEEE number	40951076
Reach-compliant	Yes
RoHS-compliant	Yes

Connection

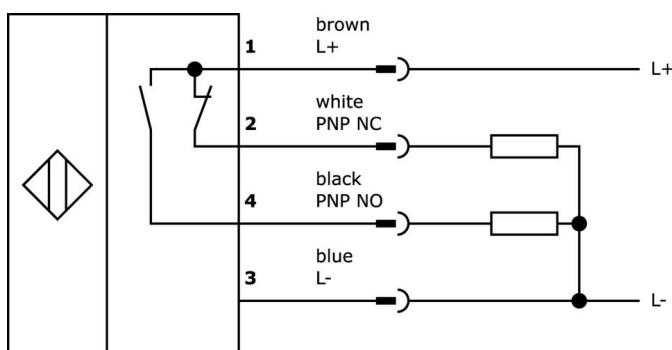

Dimensional drawing

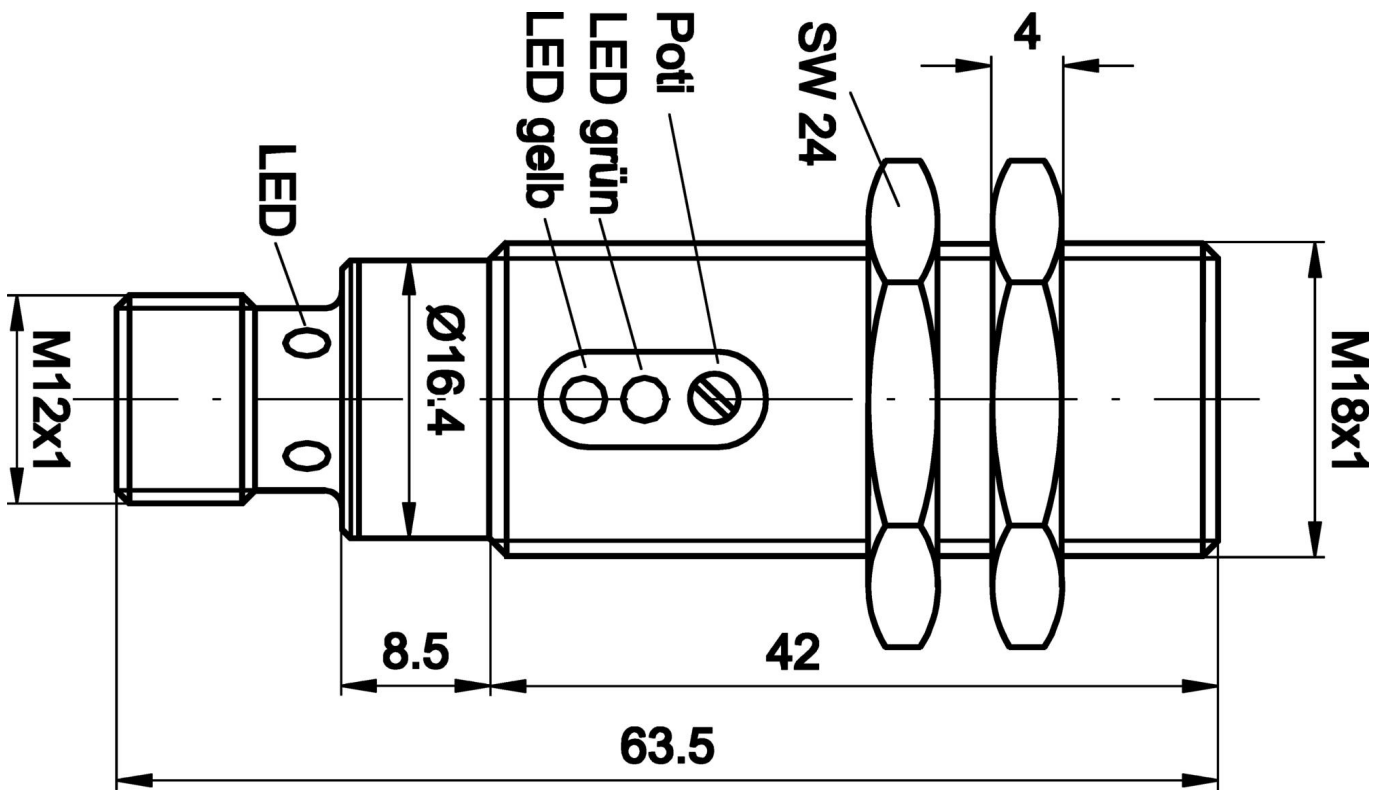

Extract accessories program

VK030F21



Connection cable, 0.3m, M12 socket 4-pin angular, M12 connector 4-pin straight, 4x0.34mm², 240V, IP67, suitable for trailing chain and torsion resistant, oils and cooling lubricants, welding area, silicone-free

VK030F25



Connection cable, 0.3m, M12 socket 4-pin straight, M12 connector 4-pin straight, 4x0.34mm², PUR (polyurethane), 240V, IP67, suitable for trailing chain and torsion resistant, oils and cooling lubricants, welding area, silicone-free

VK205321



Connection cable, 2m, M12 Female (socket) 4pin Angular, Free conductor end, 4x0.34mm², PUR (Polyurethane), Ø5.5mm, 250V, -25-90°C, IP67, Shielded, Suitable for trailing chain and torsion resistant, Oil and cooling lubricants, Welding area, Silicon...

VK205325



Connection cable, 2m, M12 Female (socket) 4pin Straight, Free conductor end, 4x0.34mm², PUR (Polyurethane), Ø5.5mm, 250V, -25-90°C, IP67, Shielded, Suitable for trailing chain and torsion resistant, Oil and cooling lubricants, Welding area, Silico...

VK003020



Cable socket, angular, self-assembly, screw connection, Ø3-6.5mm, 4A, 240V, -25-90°C, M12 socket 4-pin, IP67, PBT

VK003024



Cable socket, Straight, Suitable for self-assembly, Screw connection, Ø3-6.5mm, 4A, 240V, -25-90°C, M12 Female (socket) 4pin, IP67, PBT

AY000162



Accessories, magnetic, Ø43mm, neodymium-iron-boron, inside thread M5, rubber

AY000159



accessories sensor, Mounting pipe, Ø12mm 200long, Aluminum Anodised

VK200321



Connection cable, 2m, M12 Female (socket) 4pin Angular, Free conductor end, 4x0.34mm², PUR (Polyurethane), Ø4.7mm, 250V, -40-90°C, IP67, Suitable for trailing chain and torsion resistant, Oil and cooling lubricants, Welding area, Silicone-free

You can find further accessories on our homepage



Installation

Mounting / installation may only be carried out by a qualified electrician!



Disposal

WEEE number according to § 6 para. 3 ElektroG: 40951076

Safety warnings

/ Before initial operation, please make sure to follow all safety instructions that may be provided in the product information.

/ Never use these devices in applications where the safety of a person depends on their functionality.