

PR310370

Laser sensors • Retro-reflective sensors

Sensor laser, reflex, 42x20x11mm, Sn: 100-12000, 10-30V DC, PNP programmable/configurable, M8 plug-in connector 4-pin, IP67, plastic, ABS+PMMA, 2kHz, laser diode, red light, dot, manual setting, with polarizing filter

- / plastic housing
- / Switching output no/nc switchable
- / M8 plug connection



Laser class 1 polarizing filter

Optical sensors operate contactless. They detect objects regardless of their nature (e.g. shape, color, surface structure, material). The basic mode of operation is based on the transmission and reception of light. Three versions are distinguished: 1. the through-beam sensor consists of two separate devices, a transmitter and a receiver, which are aligned with each other. When the light beam between the two devices is interrupted, the switching output integrated in the receiver changes its status. In the case of the reflex light barrier, the transmitter and receiver are located in one device. The transmitted light beam is reflected onto the receiver by a reflector to be mounted opposite. As soon as the light beam is interrupted, the switching output integrated in the device changes its status. With diffuse reflection sensors, the transmitter and receiver are located in one device. The transmitted light beam is reflected by the object to be detected. As soon as the receiver detects the reflected light, the switching output integrated in the device changes its status.

Electrical features

Response/decay time	0.25 ms
Number of switching outputs	1
Display	LED display
Type of switching function	Programmable/configurable
Type of electrical connection	Connector M8
Type of switching output	PNP
Rated switching current	100 mA
Setting procedure	Manual adjustment Potentiometer
Short-circuit protection	Yes
No-load current	35 mA
Number of pins	4
Reaction time	0.25 ms
Residual ripple	10 %
Switching distance	100 - 12000 mm
Switching frequency	2000 Hz
Voltage drop	2 V
Scanning function	Light-/dark-on mode
Reverse polarity protection	Yes
Decay time	0.25 ms
Operating voltage (DC)	10 - 30 V
With polarizing filter	Yes

Mechanical features

Design	Cuboid
Width	10.8 mm
Height	42.3 mm
Storage temperature	-40 - 70 °C
Length	19.5 mm
Maximum tightening torque	0.4 Nm
Shock resistance, acceleration	30 g
Shock resistance, pulse time	11 ms
Degree of protection (IP)	IP67
Active area material of sensor	Plastic (PMMA)
Housing material	Plastic (ABS)
Vibration resistance Amplitude	0.5 mm
Vibration resistance Frequency	10 - 55 Hz
Ambient temperature	-25 - 55 °C

Optical features

Laser class	Class 1
Light source	Laser diode, red light
Light beam form	Point
Wavelength of the sensor	650 nm

Other features

Reference medium / object	AO000007
---------------------------	----------

Classification

ETIM 8	
--------	--

More

IPF Product Group	160 laser sensor
packaging dimensions	160 x 123 x 15 mm
gross weight	14 g
Customs tariff number	85365019
WEEE number	40951076
POP-compliant	Yes
Reach-compliant	Yes
RoHS-compliant	Yes

Connection

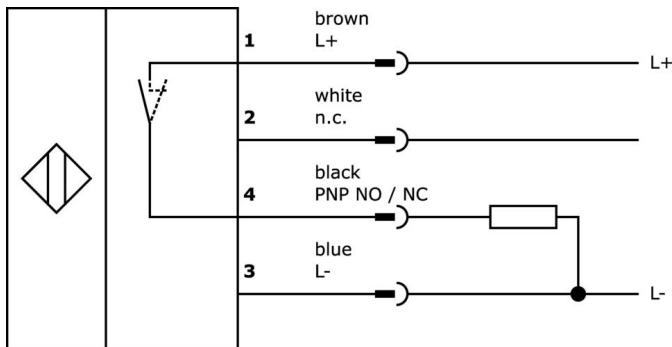

Dimensional drawing

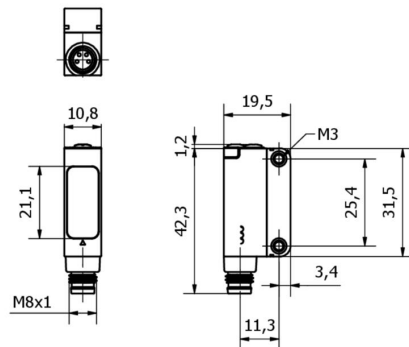

Extract accessories program

AP000027

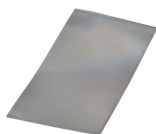

accessories laser, reflector, 100x50mm, Self-adhesive, -40-70°C, Plastic+Plastic, Polarized, Punchable and cuttable

AP000035



accessories laser, reflector, 6x59x20mm, Screw hole, 2x \varnothing 4.5mm, -40-70°C, IP67, PMMA+PMMA, Polarized, Microprisms

VK200371



Connection cable, 2m, M8 Female (socket) 4pin Angular, Free conductor end, 4x0.34mm², PUR (Polyurethane), \varnothing 4.7mm, 30V, -30-90°C, IP67, Suitable for trailing chain and torsion resistant, Oil and cooling lubricants, Welding area, Silicone-free

VK200375



Connection cable, 2m, M8 Female (socket) 4pin Straight, Free conductor end, 4x0.34mm², PUR (Polyurethane), \varnothing 4.7mm, 30V, -30-90°C, IP67, Suitable for trailing chain and torsion resistant, Oil and cooling lubricants, Welding area, Silicone-free

VK003071



Cable socket, Angular, Suitable for self-assembly, Soldering connection, \varnothing 3.5-5mm, 4A, 30V, -40-85°C, M8 Female (socket) 4pin, IP67, Brass

VK003075



Cable socket, Straight, Suitable for self-assembly, Soldering connection, \varnothing 3.5-5mm, 4A, 30V, -40-85°C, M8 Female (socket) 4pin, IP67, Brass

VK030F81



Connection cable, 0.3m, M8 socket 4-pin angular, M12 connector 4-pin straight, 4x0.34mm², PUR (polyurethane), 60V, IP67, suitable for trailing chain and torsion resistant, oils and cooling lubricants, welding area, silicone-free

VK030F85



Connection cable, 0.3m, M8 socket 4-pin straight, M12 connector 4-pin straight, 4x0.34mm², PUR (polyurethane), 60V, IP67, suitable for trailing chain and torsion resistant, oils and cooling lubricants, welding area, silicone-free

AO000004



accessories optical, reflector, \varnothing 20mm 6high, Self-adhesive, PMMA+PMMA, Polarized

You can find further accessories on our homepage



Installation

Mounting / installation may only be carried out by a qualified electrician!



Disposal

WEEE number according to § 6 para. 3 ElektroG: 40951076

Safety warnings

/ Before initial operation, please make sure to follow all safety instructions that may be provided in the product information.

/ Never use these devices in applications where the safety of a person depends on their functionality.