

AO000220 ... AO000235

Instruction Manual

Lens shield for safety light curtains

GENERAL INFORMATION

This accessory for safety light curtains, composed of a PMMA Altuglas plate that can be mounted on the front glass, ensures an effective protection against dust, chips and incandescent drops, deriving from material working near the safety light curtain. The accessory can be easily installed thanks to the fixing brackets supplied in the package that exploit the side groove of the safety light curtain.

Each package contains what is necessary to protect a single unit (TX or RX).

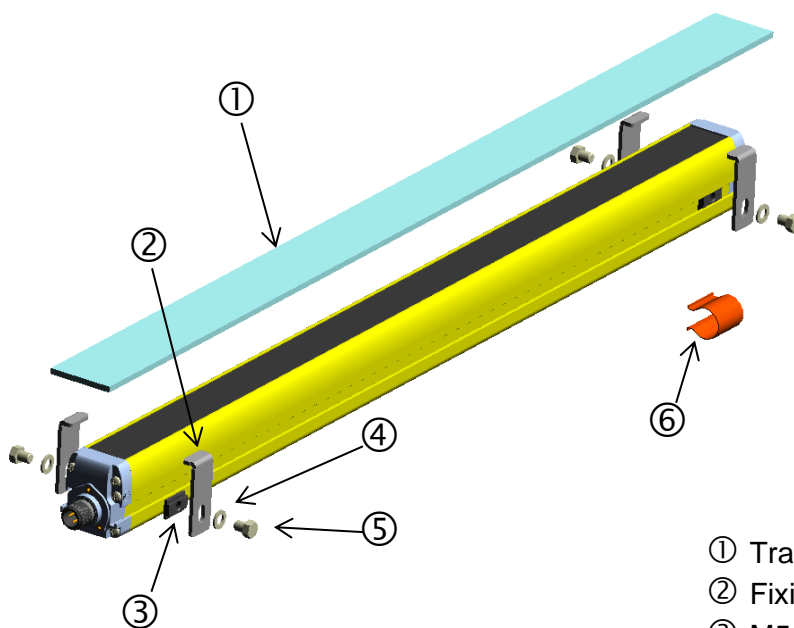
Package Contents

- ① Transparent PMMA plate (5 pieces)
- ② Fixing bracket *
- ③ M5 nut
- ④ UNI 6592 Di = 5.3 washer
- ⑤ TE M5x6 UNI 5739 screws
- ⑥ Elastic blocking spring

*②, ③, ④, ⑤, ⑥ parts

- 4 pieces for:
OY3201x0 ... OY3201x6
OY360110
OY360111
OY360112
- 6 pieces for:
OY3201x7 ... OY3201xC
OY360113

FIXING INSTRUCTIONS

Build the subassembly, shown in Fig. 1 and 2, screwing ⑤ screw to the ③ nut but not completely in order to leave space for ② and ③ parts (refer to Fig. 2).

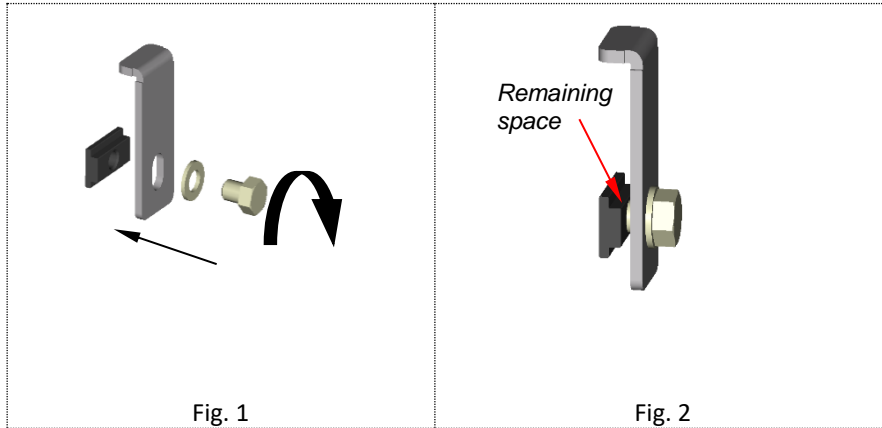

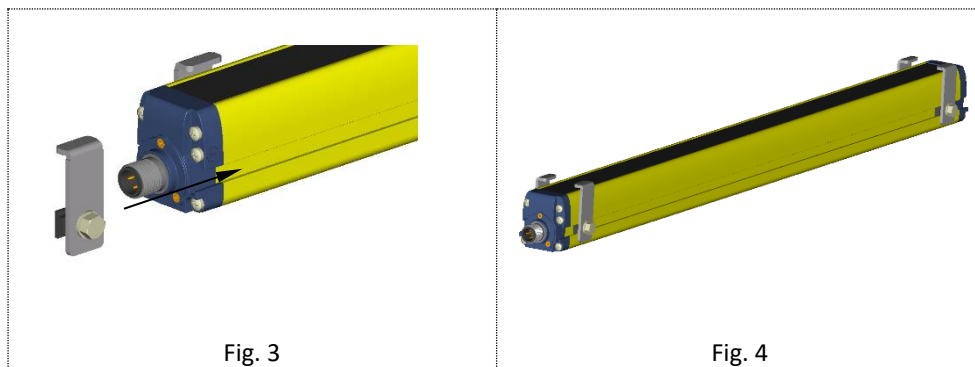

Slide the subassemblies in the product groove (OY32, OY35 or OY36 series) as shown in Fig. 3, to obtain, for example, the Fig. 4 condition. Please refer to the specific datasheet for the recommended fixing positions.

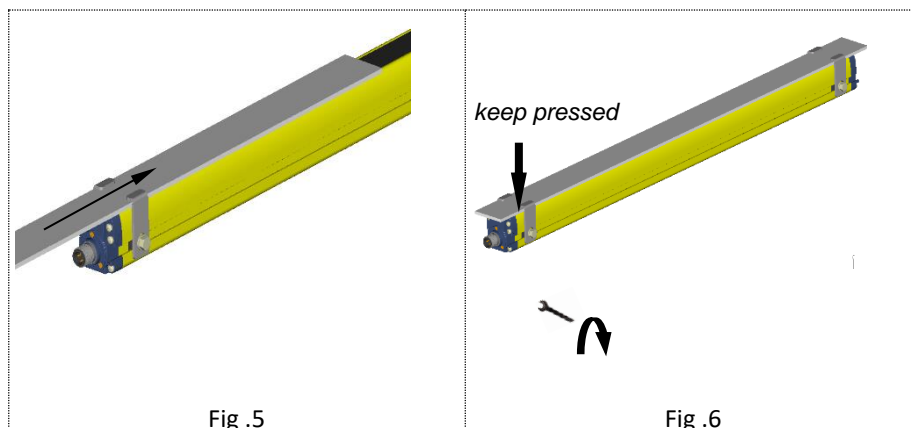

Insert the transparent plate and slide it along the binary under the fixing brackets. Once positioned correctly, tighten the screws with the N° 8 key, pressing the fixing bracket on the plate, until all the fixing brackets are blocked safely. In case of replacement, untighten the ⑤ screws without removing them, unslide the plate and then replace it.

An accessory kit of 4 elastic fasteners (⑥) is available to avoid nut (③) sliding inside the groove in vertical mounting.



 **NOTE** The maximum operating distance of the ESPE is reduced of 10% for each couple of "LENS SHIELD" used (one for TX unit and one RX unit).

DIMENSIONS

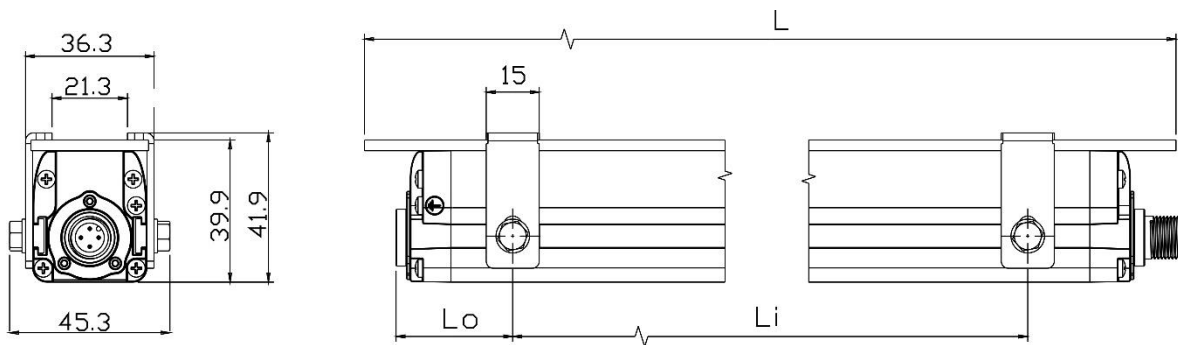

Article-No.	Description	For Light-Curtain	L (mm)	Li (mm)	Lo (mm)
AO000220	Lens shield H = 150mm	OY3201x0	245	160	30
AO000221	Lens shield H = 300mm	OY3201x1	392	345	45
AO000222	Lens shield H = 450mm	OY3201x2	540	400	60
AO000223	Lens shield H = 600mm	OY3201x3	686	520	75
AO000224	Lens shield H = 750mm	OY3201x4	832	590	115
AO000225	Lens shield H = 900mm	OY3201x5	960	640	175
AO000226	Lens shield H = 1050mm	OY3201x6	1126	740	200
AO000227	Lens shield H = 1200mm	OY3201x7	1274	445	200
AO000228	Lens shield H = 1350mm	OY3201x8	1422	520	200
AO000229	Lens shield H = 1500mm	OY3201x9	1568	595	200
AO000230	Lens shield H = 1650mm	OY3201xA	1715	670	200
AO000231	Lens shield H = 1800mm	OY3201xC	1860	745	200
AO000232	Lens shield H = 500mm	OY360110	642	490	75
AO000233	Lens shield H = 800mm	OY360111	942	640	175
AO000234	Lens shield H = 900mm	OY360112	1042	660	200
AO000235	Lens shield H = 1200mm	OY360113	1342	480	200