

Original operating Instructions for the safety relay for safety  
light curtains

**AO000299**



### Table of contents

Symbol and Notes Statement	Page 2
General Notes	Page 3
Designated use	Page 3
Safety Notes	Page 3
Function Diagram	Page 5
Block Diagram	Page 5
Main Features	Page 5
Approvals and Markings	Page 5
Applications	Page 6
Indicators	Page 6
Notes	Page 6
Circuit Diagram	Page 6
Connection Terminals	Page 6
Technical Data	Page 7
Characteristics	Page 8
Application examples	Page 9
Labeling and Connections	Page 10
Dimensions	Page 11
Unit Programming	Page 11
Safety related data	Page 12
Troubleshooting	Page 13
Maintenance and repairs	Page 13
EC Declaration of Conformity	Page 14



Before installing, operating or maintaining this device, these instructions must be carefully read and understood.



The installation must only be done by a qualified electrician!



Do not dispose of household garbage!  
The device must be disposed of in compliance with nationally applicable rules and requirements.



Storage for future reference.

To help you understand and find specific text passages and notes in the operating instructions, we have important information and information marked with symbols.

### Symbol and Notes Statement



DANGER

**DANGER:**  
Indicates that death or severe personal injury will result if proper precautions are not taken.



WARNING

**WARNING:**  
Indicates that death or severe personal injury can result if proper precautions are not taken.



CAUTION

**CAUTION:**  
Indicates that a minor personal injury can result if proper precautions are not taken.

**INFO:**  
Referred information to help you make best use of the product.



**ATTENTION:**  
Warns against actions that can cause damage or malfunction of the device, the device environment or the hardware / software result.

### General Notes

The product hereby described was developed to perform safety functions as a part of a whole installation or machine. A complete safety system normally includes sensors, evaluation units, signals and logical modules for safe disconnections. The manufacturer of the installation or machine is responsible for ensuring proper functioning of the whole system. ipf cannot guarantee all the specifications of an installation or machine that was not designed by ipf. The total concept of the control system into which the device is integrated must be

validated by the user. ipf also takes over no liability for recommendations which are given or implied in the following description. The following description implies no modification of the general ipf terms of delivery, warranty or liability claims.

### Designated use

The AO000299 is used for safe interruption of a safety circuit. It can be used to protect people and machines in applications with light curtains.

When used in accordance with its intended purpose and following these operating instructions, this device presents no known residual risks. Nonobservance may lead to personal injuries and damages to property.

### Safety Notes



#### **Risk of electrocution!**

##### **Danger to life or risk of serious injuries.**

- Disconnect the system and device from the power supply and ensure they remain disconnected during electrical installation.
- The device may only be used for the applications described in the mutually applicable operating instructions / data sheet. The notes in the respective documentation must be heeded. The permissible ambient conditions must be observed.
- The contact protection of the elements connected and the insulation of the supply cables must be designed in accordance with the requirements in the operating instructions / data sheet.
- Note the VDE and local regulations, particularly those related to protective measures.



#### **Risk of fire or other thermal hazards!**

##### **Danger to life, risk of serious injuries or property damage.**

- The device may only be used for the applications described in the mutually applicable operating instructions / data sheet. The notes in the respective documentation must be heeded. The permissible ambient conditions must be observed. In particular, the current limit curve must be heeded.
- The device may only be installed and put into operation by experts who are familiar with this technical documentation and the applicable health and safety and accident prevention regulations.

**Functional error!****Danger to life, risk of serious injuries or property damage.**

- The device may only be used for the applications described in the mutually applicable operating instructions / data sheet. The notes in the respective documentation must be heeded. The permissible ambient conditions must be observed.
- The device may only be installed and put into operation by experts who are familiar with this technical documentation and the applicable health and safety and accident prevention regulations.

**Installation fault!****Danger to life, risk of serious injuries or property damage.**

- Make sure of sufficient protection circuitry at all output contacts for capacitive and inductive loads.

**Attention!**

- The safety function must be triggered during commissioning.
- If a line fault occurs after the voltage has been connected to S12, S22, the unit will be activated because this line fault is similar to the normal On-function.
- Switch S1 must not be set while device is under supply voltage.
- AUTOMATIC START !  
According to IEC/EN 60 204-1 part 9.2.5.4.2 and 10.8.3 it is not allowed to restart automatically after emergency stop. Therefore the machine control has to disable the automatic start after emergency stop.
- Opening the device or implementing unauthorized changes voids any warranty.

**Function Diagram**

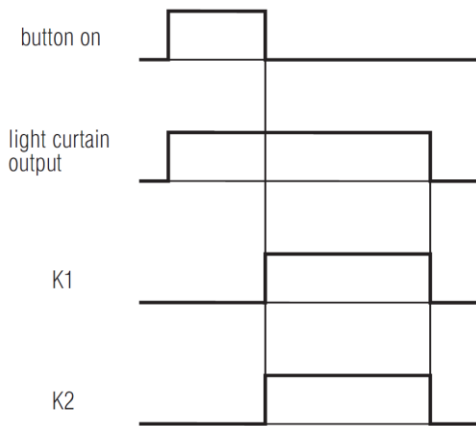

**Block Diagram**

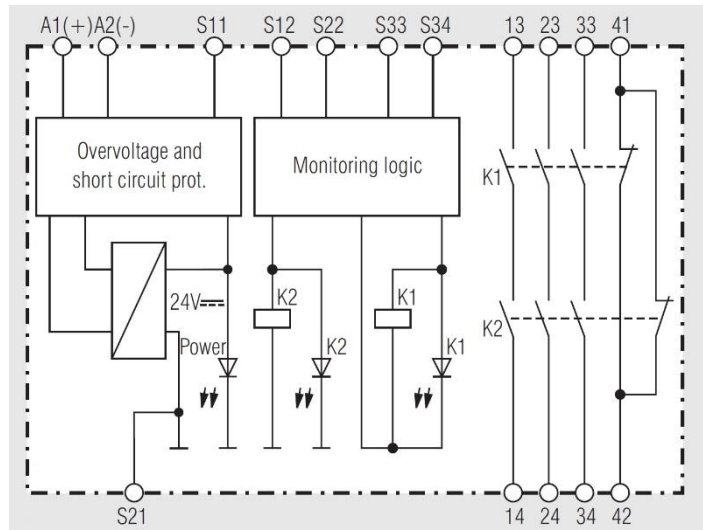

**Main Features**

- According to:
  - Performance Level (PL) e and category 4 to EN ISO 13849-1:2008
  - SIL Claimed Level (SIL CL) 3 to IEC/EN 62061
  - Safety Integrity Level (SIL) 3 to IEC/EN 61508
- According to EN 50156-2 for furnaces
- For light curtains with symmetric or asymmetric outputs, adjustment with switch S1
- Output: 3 x no, 1 x nc (the nc-contact can only be used for monitoring)
- Single and 2-channel operation
- Line fault detection on On-button (monitored start)
- Manual restart or automatic restart, switch S22
- LED indicator for state of operation
- LED indicator for channel 1 and 2 and power
- Wire connection: also 2 x 1.5 mm<sup>2</sup> stranded ferruled, or 2 x 2.5 mm<sup>2</sup> solid DIN 46 228-1/-2/-3/-4, fixed screw terminals
- Width 22,5mm

**Approvals and Markings**



**Applications**

Protection of people and machines

- Light curtain controller for light curtains with selftesting (Type 4) according to IEC/EN 61 496-1
- Usage in furnace application in continuous operation acc. to EN 50156-1

**Indicators**

upper LED: on when supply connected  
 lower LEDs: on when relay K1 and K2 energized

**Notes**

Line fault detection on On-button:

The line fault detection is only active when S12 and S22 are switched simultaneously. If The On-button is closed before S12, S22 is connected to voltage (also when line fault across On-Button), the output contacts will not close. A line fault across the On-button which occurred after activation of the relay, will be detected with the next activation and the output contacts will not close.

When using light curtains with asymmetric outputs (one output + switching, one output - switching) the MINUS switching output has to be connected to S22 and the Plus switching to S12.

**Circuit Diagram**

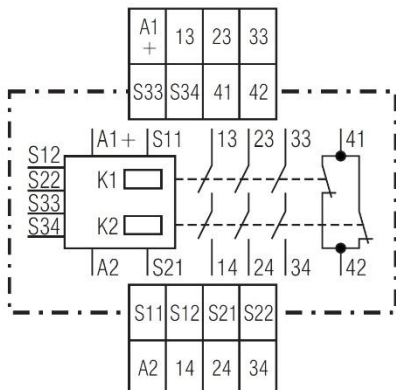

**Connection Terminals**

Terminal designation	Signal designation
A1 +	Supply Voltage +
A2 -	Supply Voltage -
S12, S22, S33, S34	Control Inputs
S11, S21	Reference points to measure the control voltage
13, 14, 23, 24, 33, 34	Forcibly guided NO contacts for release circuit
41, 42	Forcibly guided NC contact (indicator output)

**Technical Data**

Input Circuitit	
Nominal Voltage U <sub>N</sub>	24V DC

Voltage Range	0,90 ... 1,1 U <sub>N</sub>
Nominal consumption	approx. 1,7W
Min. Off-time	250ms
Control voltage on S11 at U <sub>N</sub>	22,5V DC
Control current over S12, S22	typ. 35mA at U <sub>N</sub>
Min. voltage on S12, S22 When relay activated	21V DC
Short circuit protection	internal PTC
Overvoltage protection	internal VDR

**Output**

Contacts	3 NO, 1 NC The NO contacts are safety contacts. <b>The NC contacts 41-42 can only be used for monitoring.</b>		
Contact type	Relay, forcibly guided		
Operate delay (typ.) at U <sub>N</sub>			
Manual start	20ms		
Automatic start	350ms		
Release delay (typ.) at U <sub>N</sub>			
Disconnecting S12, S22	15ms		
Nominal output voltage	max. 250V AC DC: see limit curve for arc-free operation		
Switching of low loads (contact 5µm Au)	≥ 100mV ≥ 1mA		
Thermal Current I <sub>th</sub> :	max. 8A per contact (see current limit curve)		
Switching capacity			
to AC 15	NO-contacts	2A / 230V AC	IEC/EN 60 947-5-1
	NC-contacts	2A / 230V AC	IEC/EN 60 947-5-1
to DC 13	NO-contacts	2A / 24V DC	IEC/EN 60 947-5-1
	NC-contacts	2A / 24V DC	IEC/EN 60 947-5-1
Electrical contact life to 5A, 230V AC, cosφ = 1	> 2,2 x10 <sup>5</sup> switching cycles		
Permissible operating frequency	max. 1.200 operating cycles / h		
Short circuit strength			
max. fuse rating	10A gG / gL	IEC/EN 60 947-5-1	
line circuit breaker	B 6A		
Mechanical Contact Life	> 20 x 10 <sup>6</sup> switching cycles		

**General Data**

Operating mode	Continuous operation	
Temperature range		
operation	-25 ... +55°C	
storage	-40 ... +85°C	
Altitude	< 2.000m	
Luft- und Kriechstrecken		
Bemessungsstoßspannung	4kV	
Verschmutzungsgrad	2 (Basis insulation)	IEC 60 664-1
EMC		
Interference suppression	Limit value class B	EN 55 011
Degree of Protection		
Housing	IP40	
Terminals	IP20	
Housing Material	Thermoplastic with V0-behaviour according to UL Subject 94	
Vibration resistance	Amplitude 0,35mm, Frequency 10 ... 55Hz	IEC/EN 60068-2-6
Climate resistance	25 / 055 / 04	IEC/EN 60068-1
Terminal designation	EN 50 005	
Wire fixing	Plus-Minus terminal screws M3,5 Box terminals with wire protection	
Mounting	DIN rail	IEC/EN 60 715
Weight	220g	

**Characteristics**

Arc limit curve under resistive load

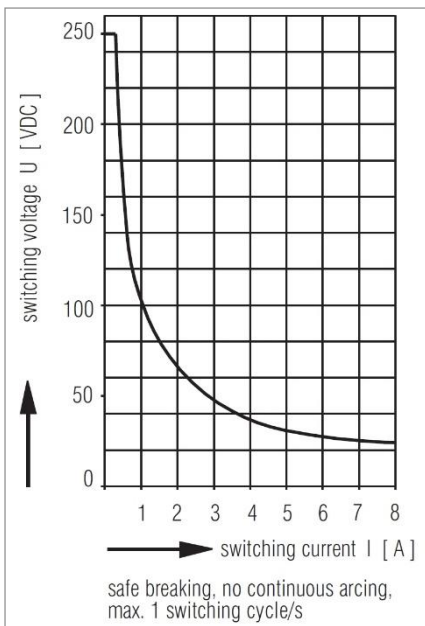

Total current limit curve

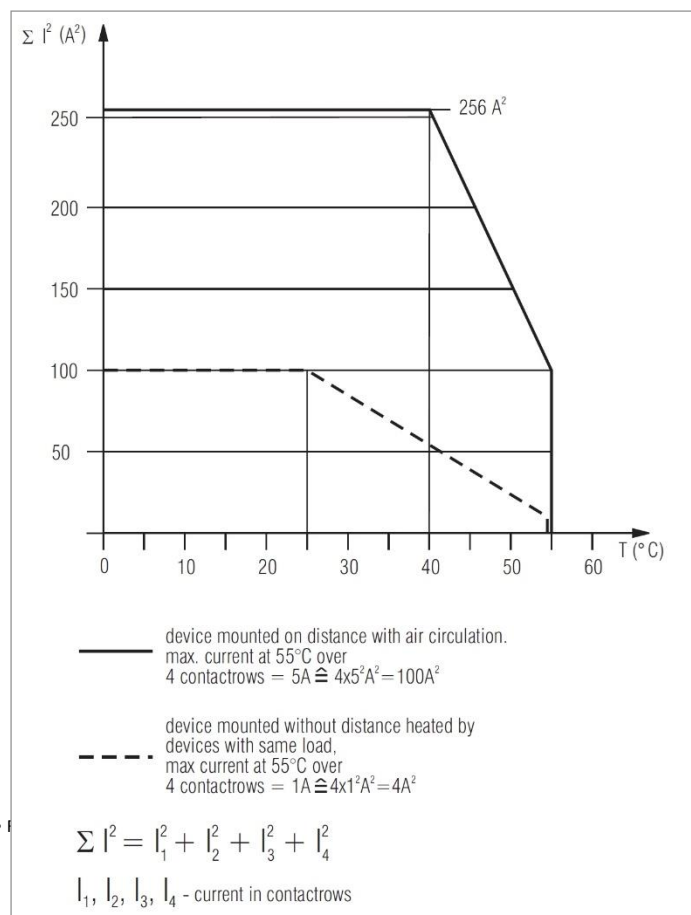

**Application examples**

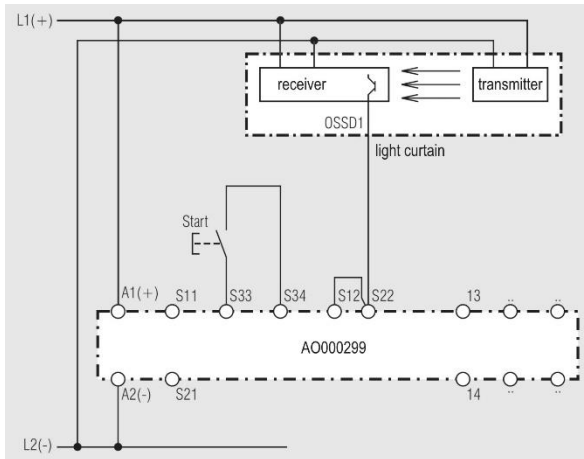

Single channel connection of light curtains with self-test according to EN 61 496-1.

Note: Refer to “Unit Programming”!

Switches in Position:

S1: “symmetric”

S2: “manual”

If you want to use the function „automatic start“, connect S33 with S34 and push the button S2 to „Auto-Start“.

Suited up to SIL2, Performance Level d, Cat. 2

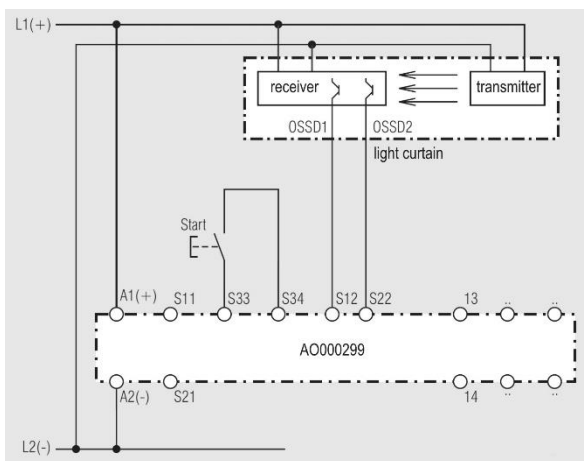

2 channel connection of light curtains with self-test according to EN 61 496-1.

Cross fault detection in the light curtain.

Note: Refer to “Unit Programming”!

Switches in Positions:

S1: With symmetric outputs on light curtains switch S1 in position “symmetric”.

With asymmetric outputs on light curtains switch S1 in position “asymmetric”.

S2: “manual”

Suited up to SIL3, Performance Level e, Cat. 4

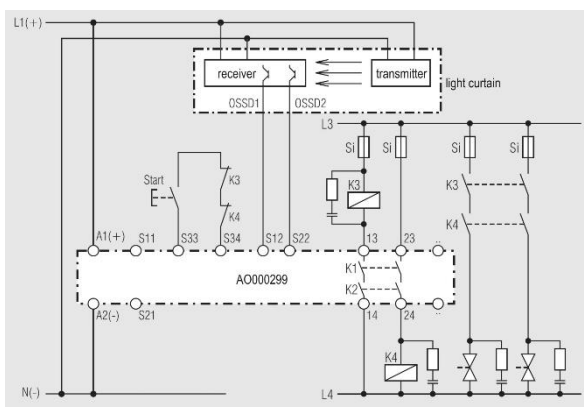

Contact reinforcement and contact extension by external contactors.

Note: Refer to “Unit Programming”!

Switches in Positions:

S1: With symmetric outputs on light curtains switch S1 in position “symmetric”.

With asymmetric outputs on light curtains switch S1 in position “asymmetric”.

S2: “manual”

Suited up to SIL3, Performance Level e, Cat. 4

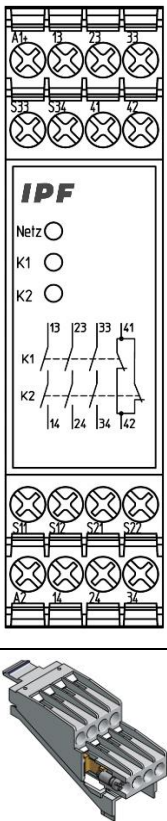
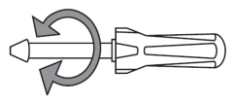
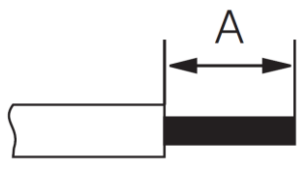
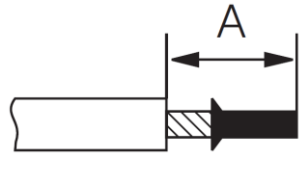
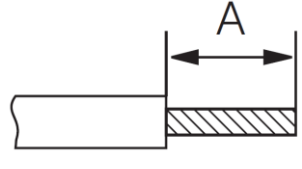

**Labeling and connections**

	 <p>The diagram shows a terminal block with two rows of terminals. The top row terminals are labeled 13, 23, 33, 41. The bottom row terminals are labeled 14, 24, 34, 42. A legend indicates: Netz (power), K1, and K2. Below the legend is a schematic showing two relays, K1 and K2, with their respective terminals. A 3D perspective view of the terminal block is shown below the diagram.</p>
	<p>∅ 4 mm / PZ 1 0,8 Nm 7 LB. IN</p>
 <p>Diagram showing a wire with a length 'A' inserted into a terminal. The wire is inserted to the end of the terminal.</p>	<p>A = 8mm 1 x 0,5 ... 4 mm<sup>2</sup> 1 x AWG 20 to 12 2 x 0,5 ... 2,5 mm<sup>2</sup> 2 x AWG 20 to 14</p>
 <p>Diagram showing a wire with a length 'A' inserted into a terminal. The wire is inserted to the end of the terminal, with a shaded area indicating the contact point.</p>	<p>A = 8mm 1 x 0,5 ... 2,5 mm<sup>2</sup> 1 x AWG 20 to 14 2 x 0,5 ... 1,5mm<sup>2</sup> 2 x AWG 20 to 16</p>
 <p>Diagram showing a wire with a length 'A' inserted into a terminal. The wire is inserted to the end of the terminal, with a shaded area indicating the contact point.</p>	<p>A = 8mm 1 x 0,5 ... 4mm<sup>2</sup> 1 x AWG 20 to 12 2 x 0,5 ... 2,5mm<sup>2</sup> 2 x AWG 20 to 14</p>

**Dimensions (in mm)**

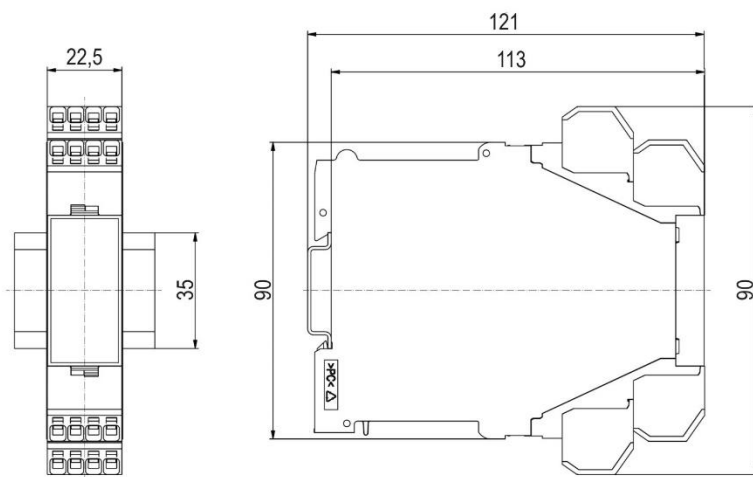

**Unit Programming**

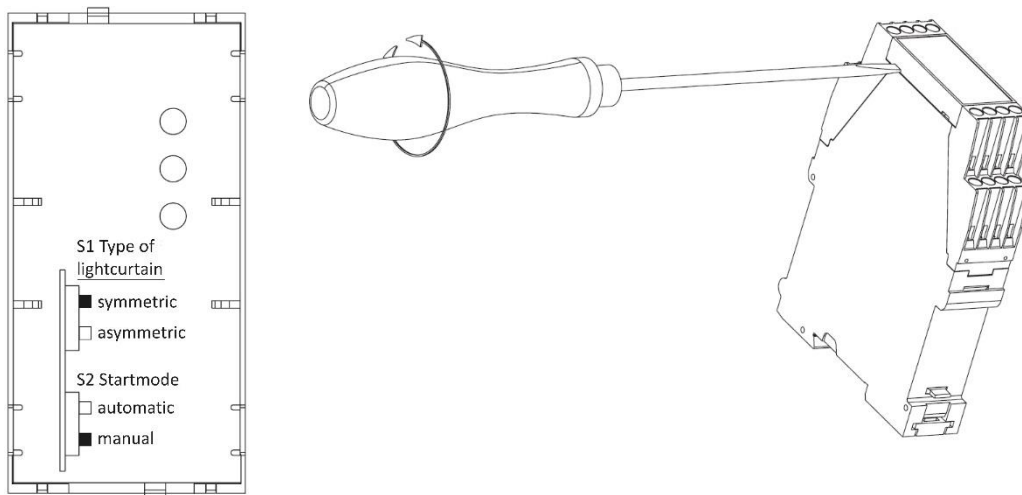

To set the switches S1 and S2 please remove the cover of the AO000299 in assistance of a screwdriver etc. (see illustration).

The Drawing shows setting at the state of delivery.

Disconnect the unit before setting of S1!

**Safety Related Data**

**EN ISO 13849-1**

Category	4
PL	e
MTTF <sub>d</sub>	216,7a (year)
DC <sub>avg</sub>	99,0%
d <sub>op</sub>	365d/a (days/year)
h <sub>op</sub>	24h/d (hours/day)
t <sub>cycle</sub>	3600s/cycle (≅ 1/h)

**IEC/EN 62061**

**IEC/EN 61508**

**IEC/EN 61511**

SIL CL	3 (IEC/EN 62061)
SIL	3 (IEC/EN 61508, IEC/EN 61511)
HFT (hardware failure tolerance)	1
DC	99,0%
PFH <sub>D</sub>	1,1 x 10 <sup>-10</sup> h <sup>-1</sup>
PFDAVG	8,2 x 10 <sup>-5</sup> (Low Demand Mode)
T <sub>1</sub>	20a (year)

Demand to our device based on the evaluated necessary safety level of the application at High Demand Mode		Intervall for cyclic test of the safety function
Acc. to EN ISO 13849-1	PL e with Cat. 3 or Cat. 4	once per month
	PL d with Cat. 3	once per year
Acc. to IEC/EN 62061, IEC/EN 61508	SIL CL 3, SIL 3 with HFT = 1	once per month
	SIL CL 2, SIL 2 with HFT = 1	once per year



The safety relevant data of the complete system has to be determined by the manufacturer of the system.

**Troubleshooting**

<b>Failure:</b>	<b>Potential Course:</b>	<b>Action:</b>
LED „Power“ does not light up	- Power supply not connected	- Switch on the power supply!
LED „K1“ lights up, but „K2“ remains off	- Safety relay K1 is welded - A 1-channel switch-off occurred on S12	- Replace the device! - Switch channel off on S22!
LED „K2“ lights up, but „K1“ remains off	- Safety relay K2 is welded - A 1-channel switch-off occurred on S22	- Replace the device! - Switch channel off on S12!
Device cannot be activated	Manual Start Mode: - Line fault on start-button  Automatic Start Mode: - S33-S34 not bridged - A safety relay is welded - Incorrect setting of switch S1	- Disconnect power supply and remove fault!  - Connect S33 with S34! - Replace the device! - Control switch S1 und bring it in the correct position!

**Maintenance and repairs**

- The device contains no parts that require maintenance
- In case of failure, do not open the device but send it to the manufacturer for repair.

**EC-Declaration of Conformity**

The

**ipf electronic gmbh**  
**Kalver Str. 27**  
**D – 58515 Lüdenscheid**

declares hereby that the following product:

product description: safety switching device for electro-sensitive protective devices  
type designation: **AO000299**

conforms to the following European Standards:

EMC Directive:	2014/30/EU
Machinery Directive:	2006/42/EC
RoHS Directive:	2011/65/EU
Basis of testing:	DIN EN ISO 13849-1 :2008 DIN EN 62061 :2013 DIN EN 60947-5-1 :2010 DIN EN 60204-1 :2009 DIN EN ISO 13850 :2008 DIN EN 50178 :1998 DIN EN61508-1 :2011

The product has been validated by the following testing institutes:

TÜV Rheinland Industrie Service GmbH  
Alboinstraße 56  
D - 12103 Berlin

Name of the documentation representative: Jörg Hesse  
Adress of the documentation representative: see adress of the manufacturer

Lüdenscheid, 20.04.2016

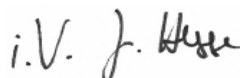

Jörg Hesse  
quality management representative

This declaration confirms the conformity of the mentioned directives but does not comprise any guarantee of the product characteristics. The safety directives of the product documentation are to be considered.

# EC Type-Examination Certificate



Product Safety  
Functional  
Safety

www.tuv.com  
ID 0600000000

**Reg.-Nr./No.: 01/205/5153.01/15**

<b>Prüfgegenstand</b> <b>Product tested</b>	Nachschaltgerät für berührungslos wirkende Schutzeinrichtungen Safety relay unit for safety light curtains	<b>Zertifikatsinhaber</b> <b>Certificate holder</b>	ipf electronic gmbh Kalver Str. 27 58515 Lüdenscheid Germany
<b>Typbezeichnung</b> <b>Type designation</b>	AO000299		
<b>Prüfgrundlagen</b> <b>Codes and standards</b>	EN ISO 13849-1:2008 + AC:2009 EN 62061:2005 + AC:2010 + A1:2013 EN ISO 13850:2008	EN 60947-5-1:2004 + AC:2005 + A1:2009 EN 60204-1:2006 + A1:2009 + AC:2010 (in extracts) EN 50178:1997	
<b>Bestimmungsgemäße Verwendung</b> <b>Intended application</b>	Das Gerät erfüllt die Anforderungen der Prüfgrundlagen (Kat. 4 / PL e nach EN ISO 13849-1, SIL CL 3 nach EN 62061) und kann in Anwendungen bis PL e und SIL 3 eingesetzt werden. The device complies with the requirements of the relevant standards (Cat. 4 / PL e acc. to EN ISO 13849-1, SIL CL 3 acc. to EN 62061) and can be used in applications up to PL e and SIL 3.		
<b>Besondere Bedingungen</b> <b>Specific requirements</b>	Die Hinweise in der zugehörigen Installations- und Betriebsanleitung sind zu beachten. The instructions of the associated Installation and Operating Manual shall be considered.		

Es wird bestätigt, dass der Prüfgegenstand mit den Anforderungen nach Anhang I der Richtlinie 2006/42/EG über Maschinen übereinstimmt.  
It is confirmed, that the product under test complies with the requirements for machines defined in Annex I of the EC Directive 2006/42/EC.

Gültig bis / Valid until 2020-11-02

Der Ausstellung dieses Zertifikates liegt eine Prüfung zugrunde, deren Ergebnisse im Bericht Nr. 968/EZ 518.01/15 vom 02.11.2015 dokumentiert sind.

Dieses Zertifikat ist nur gültig für Erzeugnisse, die mit dem Prüfgegenstand übereinstimmen. Es wird ungültig bei jeglicher Änderung der Prüfgrundlagen für den angegebenen Verwendungszweck.

The issue of this certificate is based upon an examination, whose results are documented in Report No. 968/EZ 518.01/15 dated 2015-11-02.

This certificate is valid only for products which are identical with the product tested. It becomes invalid at any change of the codes and standards forming the basis of testing for the intended application.

Berlin, 2015-11-02



Notified Body for Machinery, NB 0035

*E. Frejno*  
Dipl.-Ing. Eberhard Frejno

www.fs-products.com  
www.tuv.com

**TÜVRheinland®**  
Genau. Richtig.