

**DW34312x**  
pressure sensor



**table of contents**

safety instructions	page 3
controls and indicating elements	page 4
description of the operating elements	page 5
menu / overview	page 6
operation modes of the switching outputs	page 8
switch-point with release position	page 8
switch-point with hysteresis	page 9
window function with release position	page 9
window function with hysteresis	page 10
operating modes	page 11
programming	page 12
list of parameters	page 12
mounting and electrical connection	page 15
initial operation / operation	page 16
factory settings / technical data	page 17
dimensional drawings / list of articles	page 18

**safety instructions**

Read the product description before installing the unit. Ensure that the product is suitable for your application without any restrictions.

Non-adherence to the operating instructions or technical data can lead to personal injury and/or damage to property.

In all applications check compliance of the product materials (see technical data) with the media to be measured.

Do never touch the pressure membrane with the fingers or any other object. The membrane can be damaged irreparably!

Never use these articles in applications where the safety of a person depends on their functionality!

**controls and indicating elements**

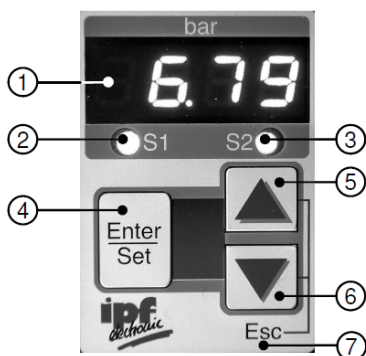

	description	function	symbol
1	4-digit display	displays the current system pressure parameter, parameter values	
2	LED red S1	displays the switching state of output 1 lights, if the output is switched	-
3	LED red S2	displays the switching state of output 2 lights, if the output is switched	-
4	programming button Enter/ Set	selection of menus and parameters setting and saving of parameters	
5	arrow key up	setting the parameter values increasing the value (fast, keep the button pressed stepwise by pressing the button short)	
6	arrow key down	setting the parameter values decreasing the value (fast, keep the button pressed stepwise by pressing the button short)	
7	ESC	finishing programming without saving key lock: press both the arrow keys at the same time	

**description of the operational controls**

**display**

4-digit lighted LED display

symbolic description:



shows the current system pressure (RUN-Mode), menu name, parameters and parameter values.



blinking display in RUN-Mode: fault report (Error).

3 x blinking in PROGRAMM mode: saving current value after pressing Enter/Set button.



The indication on the display depends on the programmed function. If one of these functions is selected in the enhanced Menu, the indication will be shown on the display.

**program button Enter/Set**

symbol:



Selection of menus and submenus as well as confirming and saving of parameter values. **Short** pressing in the RUN-Mode → starting up the base menu.

**arrow keys**

symbol:



Increasing and decreasing the parameter values and scrolling of the menu. Pressing the button continuously, the value increases or decreases in „fast-forward“ mode. Pushing the button → the value changes step by step.

**ESC- button**

symbol:



Pressing both arrow keys + **at the same time** results in the **ESC** function. With the ESC function you can step backwards inside the menu and parameters without saving the settings.

In order to leave all menus and submenus please press the **ESC**-button again and again until you are back in the RUN-mode.

**key lock**

If the device is in the RUN-Mode and you press the arrow keys + at the same time for at least 5 seconds, the key lock will be activated.

The display shows „sLOC“, blinking 3 times.

Now the adjusted settings can be read but not be changed.

For cancelling the key lock please press both arrow keys + for at least 5 seconds again.

**menu / overview**

**1. level**

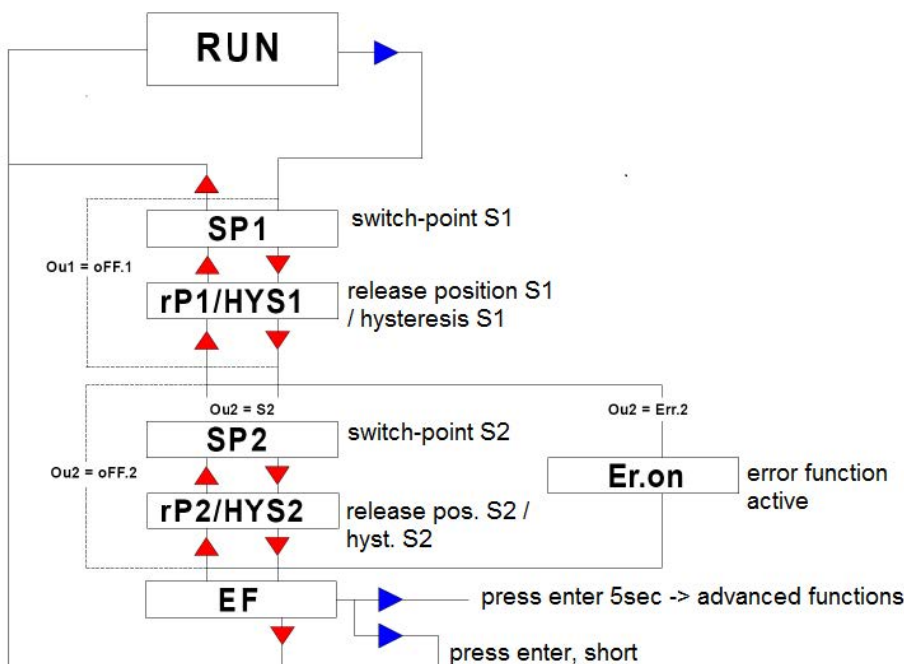

## 2. level

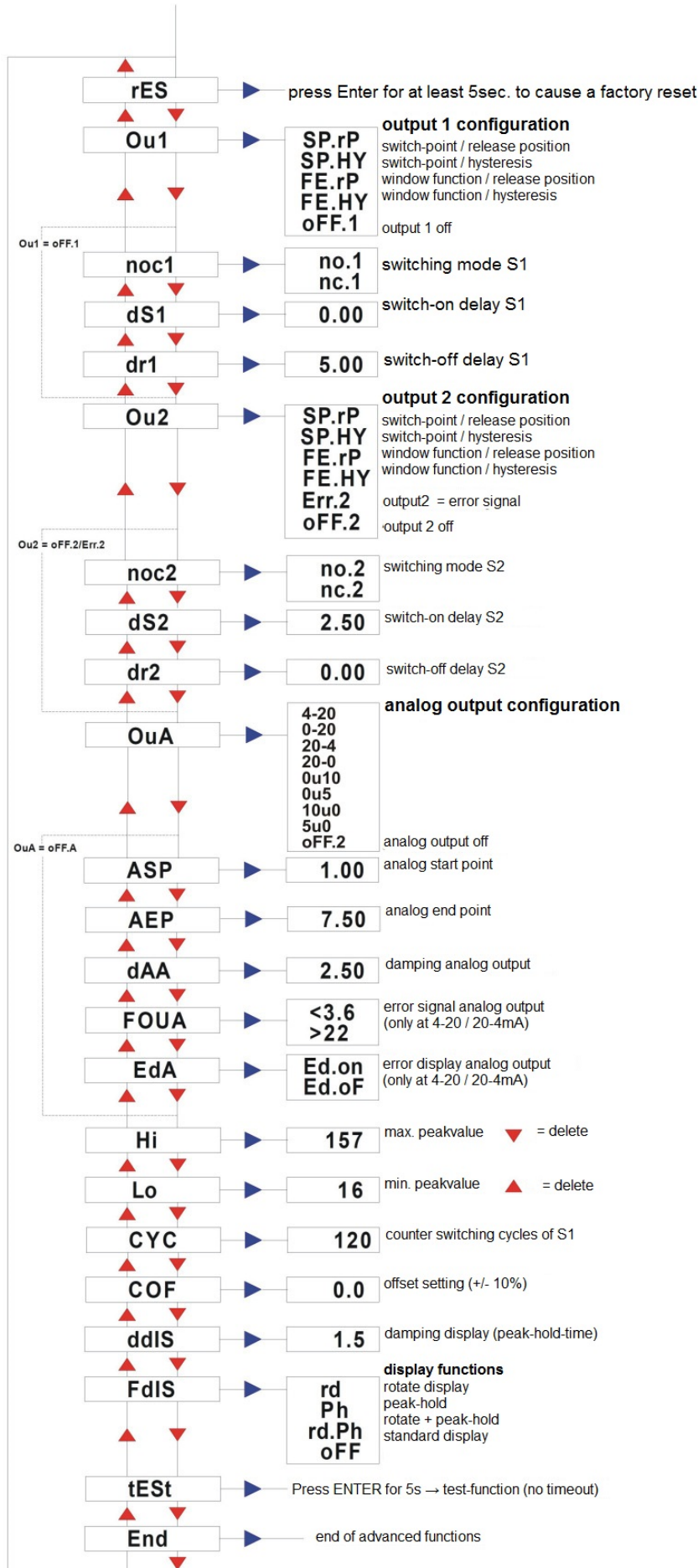







## operating modes

### **RUN-mode**

Normal operating mode.

At power on the unit is in the Run mode. It carries out its measurement and evaluation functions and provides output signals according to the set parameters.

The display shows the current system pressure. The red LEDs indicate the switching state of the outputs.

### **display mode**

Display and setting of switch-points, release positions and hysteresis.

When the *Enter/Set* button is pressed briefly, the unit passes to the main menu. The internal sensing, processing and output functions of the unit continue as if in Run mode. The parameter values can be read and adjusted.

Pressing the arrow key „downwards“ briefly, scrolls through the adjustable parameters. Pressing the *Enter/Set* button briefly, indicates the adjusted parameter value.

Pressing the arrow key „downwards“ or „upwards“ briefly, changes the parameter value step by step. Pressing the arrow key continuously changes the value fast.

Pressing the *Enter/Set* button saves the adjusted value, the display blinks three times. The unit now operates with the „new adjusted“ value.

Returning to the RUN-Mode: Press the *ESC* button.

### **enhanced menu/ programming mode**

Setting of the parameter values and programming the main functions.

The unit changes to the programming mode if „EF“ is set in the main menu and the *Enter/Set* button is pressed for at least 5sec.

The internal sensing, processing and output functions of the unit continue as if in Run mode.





Pressing the arrow key „downwards“ briefly, scrolls through the adjustable parameters.

Pressing the *Enter/Set* button briefly, indicates the adjusted parameter value

Pressing the arrow key „downwards“ or „upwards“ briefly, changes the parameter value step by step. Pressing the arrow key continuously changes the value fast.

Pressing the *Enter/Set* button saves the adjusted value, the display blinks three times. The unit now operates with the „new adjusted“ value.



Returning to the RUN-Mode: Press the *ESC* button several times.

programming		
button	display	description
 1X	<b>SP1</b>	Press the Enter/Set button briefly to get into the main menu. Press the Enter/Set button again. The current value for switch-point S1 will be displayed.* Set the parameter value with the arrow keys. Confirm the set value with the Enter/Set button.
 1X	<b>rP1 / HYS1</b>	Press the Enter/Set button. The current value for the release position S1 respectively the hysteresis will be displayed.* Set the requested value with the arrow keys. Confirm the value with the Enter/Set button.
 1X		Output 2 is set as switching output <b>SP2 / rP2</b> respectively <b>HYS2</b> . Changes can be made as described above. Output 2 gives an error signal: <b>Er.On</b> As soon as the Outputs become inactive, <b>EF</b> will be displayed.
 1X	<b>EF</b>	Press Enter/Set or  briefly to get into the RUN Mode. Press the Enter/Set button continuously for min. 5sec to get into the advanced functions. A point is blinking in the display as long as the button is pressed. Changes inside the menu items can be made as described above. The possible menu items can be seen in the parameter list.

\*a flashing point on the display indicates that a value can be changed. After confirming the set value the displayed value will blink three times.

parameter list	
<b>SP1</b>	switch-point S1
<b>HYS1 / rP1</b>	hysteresis S1 / release poosition S1
<b>SP2</b>	switch-point S2
<b>HYS2 / rP2</b>	hysteresis S2 / release position S2
<b>EF</b>	This menu item encloses a sub menu which contains further parameters. Press the Enter/Set for at least 5sec to get access to these parameters.
<b>rES</b>	Reset (getting back to the factory settings) Press the Enter/Set button at least for 5sec to reset the system. Thereafter the unit returns into the RUN Mode automatically.

<p><b>Ou 1</b></p>	<p>Configuration of output1:                  Four switching functions are possible:  <b>SP.HY</b> switch-point / hysteresis  <b>SP.rP</b> switch-point / release position  <b>FE.HY</b> window function / hysteresis  <b>FE. rP</b> window function / release position  <b>oFF.1</b> output 1 „off“</p>
<p><b>noc 1</b></p>	<p><i>noc 1 is only active if in Ou 1 a switching function is set.</i>                  Function of switching output S1:  <b>no.1</b> (normally open)  <b>nc.1</b> (normally closed)</p>
<p><b>ds 1</b></p>	<p><i>ds 1 is only active if in Ou 1 a switching function is set.</i>                  on-delay timer function S1</p>
<p><b>dr 1</b></p>	<p><i>ds 1 is only active if in Ou 1 a switching function is set.</i>                  off-delay timer function S1</p>
<p><b>Ou 2</b></p>	<p>Configuration output 2:                  Four switching functions, the error signal or 4 analog functions are possible:  <b>SP.HY</b> switch-point / hysteresis  <b>SP.rP</b> switch-point / release position  <b>FE.HY</b> window function / hysteresis  <b>FE. rP</b> window function / release position  <b>Err. 2</b> error signal  <b>oFF.2</b> output 2 „off“</p>
<p><b>noc 2</b></p>	<p><i>noc 2 is only active if Ou 2 is set as switching function.</i>                  Function of switching output S2:  <b>no.2</b> (normally open)  <b>nc.2</b> (normally closed)</p>
<p><b>dS 2</b></p>	<p><i>dS 2 is only active if Ou 2 is set as switching function.</i>                  ready-on delay-time S2</p>
<p><b>dr 2</b></p>	<p><i>dr 2 is only active if Ou 2 is set as switching function.</i>                  ready-on delay-time S2</p>
<p><b>Ou A</b></p>	<p>analog output configuration:                  4-20 analog signal 4-20mA                  0-20 analog signal 0-20mA                  20-4 analog signal 20-4mA                  20-0 analog signal 20-4mA                  0u10 analog signal 0-10V                  0u5 analog signal 0-5V                  10u0 analog signal 10-0V                  5u0 analog signal 5-0V                  oFF.A analog output off</p>

<b>ASP</b>	<i>ASP is only active if in Ou 2 an analog signal was set.</i> Analog starting point: The pressure value (low pressure) where the analog output starts.
<b>AEP</b>	<i>AEP is only active if in Ou 2 an analog signal was set.</i> Analog end point: The pressure value (higher pressure), where the analog signal ends. <b>Note:</b> The minimum range between starting point and end point is 20% of the measuring range for the DW34 type.
<b>dAA</b>	<i>dAA is only active if in Ou A an analog signal was set.</i> Damping the analog output: This function filters peak values of short duration or high-frequency dAA-value = response time. Period of time between the changing of the pressure and the analog signal in seconds.
<b>FOUA</b>	<i>FOUA is only active if in Ou A an analog signal was set.</i> Error signal of the analog output. The analog output signal is <3.6mA or >22mA (for 4-20mA/ 20-4mA only)
<b>EdA</b>	Error display of the analog output. (for 4...20mA/ 20...4mA only)
<b>HI</b>	saving the max. pressure value of the system. The highest value is displayed.  = delete memory
<b>LO</b>	Saving the min. pressure value of the system. The lowest value is displayed.  = delete memory.
<b>CYC</b>	counter switching cycles of S!
<b>COF</b>	zero-point calibration The internal measurand (operating value of the sensor) is offset compared to the real measurand. adjustment range: +/-10% of the measuring span.
<b>ddIS</b>	Damping of the display (Peak-Hold-Time)
<b>FdIS</b>	Display functions: <b>rd</b> rotate display <b>Ph</b> peak-hold. Temporary display of peak values <b>Rd. Ph</b> rotate display + peak hold <b>oFF</b> standard display

<b>tEst</b>	<p>Press Enter/Set button for 5sec, then test-function (no timeout)                  With the Test-function you can check the adjusted parameters without influence for the system.                  The display starts with indicating the current pressure.                  Due to the arrow keys the displayed value can be increased or decreased. All parameters react as if the real pressure would increase or decrease.                  Leave the Test Mode with ESC.</p>
<b>END</b>	<p>End of enhanced functions.                  Press the Enter/Set button twice to get into the RUN mode again.</p>

The units come with an optical interface that allows all parameters to be set and adjusted by a PC or notebook.

The suitable interface cable and Windows-Software can be ordered with the article number AD000011.

With the Software you are able to adjust all functions described above.

**mounting and electrical connection**

Before mounting and removing the unit: Make sure that no pressure is applied to the system.

Mount the pressure sensor DW34 on a G1/2 – process connection.

After mounting the sensor mechanically, the control panel can be rotated by 350°.

Do not touch the opening of the pressure connection with finger or a sharp object.

This causes irreparable damage to the mebrane!

The unit must be connected by a suitably qualified electrician. The national and international regulations for the installation of electrical equipment must be observed.

Voltage supply to EN50178.

Disconnect power before connecting the unit as follows:

<p>+U<sub>B</sub>: brown (2)                  GND: blue (7)                  analog output: green (3)                  switching output S1: yellow (4)                  switching output S2: grey (5)</p>	<p>N.C. white (1)                  N.C. pink (6)                  N.C. red (8)</p>
---	--

**NOTE:** Use a shielded cable socket (e.g. VK205A21), in order to avoid interferences.

**implementing / operation**

After mounting, electrical connection and programming, please check the safety of the unit.

Fault indications during operation

display	cause	effect on the outputs	elemination
<b>OL</b>	overload exceeding the measuring range (sensor-limit) > 120%Pnominal		-limit the system pressure to Pnominal. If necessary use a unit with higher measuring range
<b>UL</b>	underload system pressure is lower than the measuring range		
<b>SC1</b>	short-circuit S1	analog output= error signal*	- check wiring - check load of S1
<b>SC2</b>	short-circuit S2	analog output= error signal*	- check wiring - check load of S2.
<b>SC</b>	short-circuit S1 and S2	analog output= error signal	- check wiring - check load
<b>ERR</b>	sensor defect, internal error	-S1 and S2 are switched off - analog output = error signal*	contact manufacturer
<b>AO</b>	if current output is selected: analog-output open  if voltage output is selected: short-circuit or voltage is applied		- check wiring - check burden resistance. <b>NOTE:</b> If this indication is undesired, the menu item Eda can be set <b>Ed.of.</b>

\* the error signal of the analog output appears only, if in Ou2 an analog signal (4...20mA or 20...4mA) was set.  
The error signal (< 3.6mA or >22mA) can be set in menu item FOuA.

factory settings	
OU 1	SP.rP
OU 2	4 ... 20
SP 1	50% of nominal pressure
rP 1	10% of nominal pressure
SP 2	75% of nominal pressure
rP 2	10% of nominal pressure

## Technical Data

pressure range [bar]	see list of articles
excess pressure [bar]	150% of nominal pressure ( $P_N$ )
pressure detection	peak value memory every 2msec (display via PC)
operating voltage $U_B$	12 ... 32V DC, reverse polarity protection (15 ... 32V DC, if operated with voltage output)
voltage drop	< 2V
current consumption	< 60mA
switching outputs	2 x pnp-switching, no/nc, 250mA short-circuit protection
time delay	0 to 20sec, on-/off-delay adjustable separately
adjustment range switch- point release position	1 ... 100% of $P_N$ , 0 ... 99% of $P_N$
sampling frequency	max. 125Hz
repeatability	< $\pm 0.1\%$ of accumulated value
current output	0/4 ... 20mA, 20 ... 0/4mA, start- and end-point selectable
burden	max. $R_L [\Omega] = (U_B - 8V) / 20mA$
voltage output	0 ... 5/10V, 5/10 ... 0V, start- and end point selectable
burden	min. 5k $\Omega$
error recognition	analog outp. if line breakage (current) - short-circuit (voltage, $\geq 1V$ )
rise time	5msec (10% ... 90% of $P_N$ )
damping	0 ... 20sec, adjustable
linearity deviation system	max. $\pm 0.25\%$ of $P_N$
pressure display	4 x 7 segment LED-display
switching function display	2x LED red
display damping	0 ... 20sec, adjustable
operating temperature	-20 °C ... +80 °C
temperature drift	< $\pm 0.2\%$ / 10K (-10 °C ... +70 °C)
conn. to pressure system	DW35: G1/4A, SW 22 (DW36: G1/8, SW22)
sensor head material	stainless steel 1.4435
housing material	PA6.6, polyester
degree of protection	IP65 acc. EN 60529
electrical connection	M12 connector, 8-pin
optical interface	9600 Baud, via optical adapter at USB-port

**dimensional drawings**

fig.1: DW34xxxx

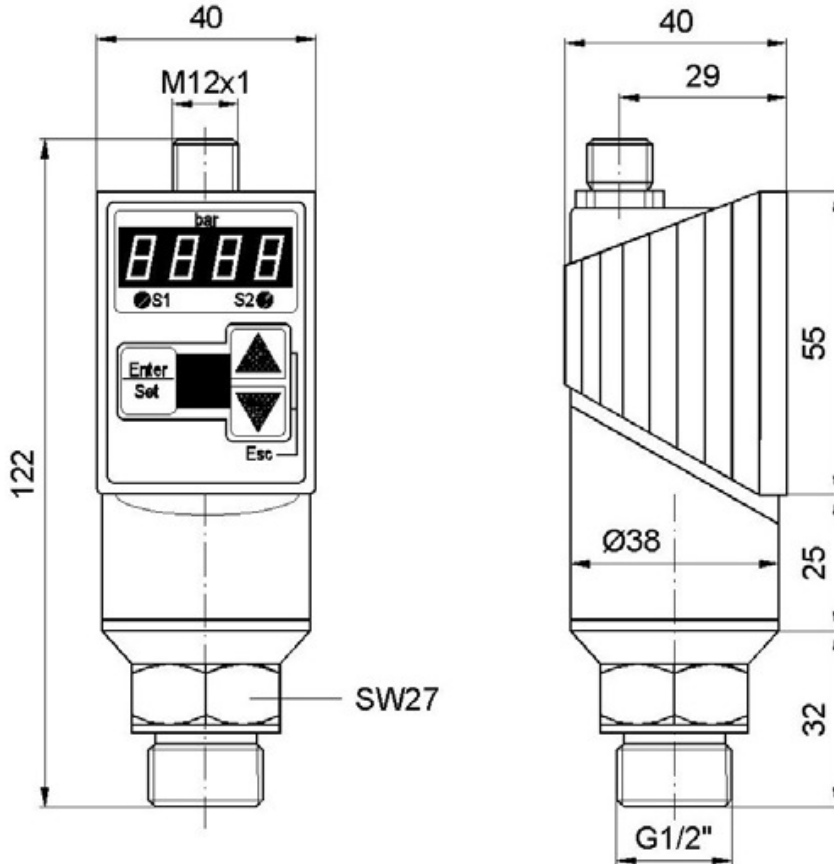

**list of articles**

article-no	design	description	housing	voltage	output	connection	fig.
DW34312D	34-G1/2A	10bar, stainless steel	polyester/V4A	12-32V DC	pnnp,no/nc,analog	M12-conn8pin	1
DW34312F	34-G1/2A	50bar, stainless steel	polyester/V4A	12-32V DC	pnnp,no/nc,analog	M12-conn8pin	1
DW343124	34-G1/2A	100bar, stainless steel	polyester/V4A	12-32V DC	pnnp,no/nc,analog	M12-conn8pin	1
DW34312G	34-G1/2A	200bar, stainless steel	polyester/V4A	12-32V DC	pnnp,no/nc,analog	M12-conn8pin	1
DW343126	34-G1/2A	400bar, stainless steel	polyester/V4A	12-32V DC	pnnp,no/nc,analog	M12-conn8pin	1
DW343127	34-G1/2A	600bar, stainless steel	polyester/V4A	12-32V DC	pnnp,no/nc,analog	M12-conn8pin	1
DW34312K	34-G1/2A	-1...+10bar, stainless st.	polyester/V4A	12-32V DC	pnnp,no/nc,analog	M12-conn8pin	1
AY000060		accessory		mounting clip			w/o
AD000011		accessory		optical interface	connection USB, software	1.5m cable	w/o

Other pressure ranges and versions on request.