

**MW208120**

**Table of contents**

**1** Warranty information ..... Page 1

**2** Identification ..... Page 1

**3** Installation..... Page 2

**3.1** Mounting the magnetic strip.....Page 2

**3.2** Mounting the magnetic sensor .....Page 3

**4** Electrical connection ..... Page 4

**4.1** Pin assignment.....Page 4

**5** Commissioning..... Page 5

**5.1** SSI-interface.....Page 5

**5.2** Zero-setting .....Page 5

**6** Maintenance..... Page 6

**7** Trouble shooting..... Page 6

**8** List of commands / service mode ..... Page 6

**9** Technical data..... Page 8

**9.1** Sensor MW208120.....Page 8

**9.2** Magnetic strip AM000069.....Page 9

**1. Warranty information**

In order to carry out installation correctly, we strongly recommend this document is read very carefully. This will ensure your own safety and the operating reliability of the device.

Your device has been quality controlled, tested and is ready for use. Please observe all warnings and information which are marked either directly on the device or specified in this document.

Warranty can only be claimed for components supplied by ipf electronic gmbh. If the system is used together with other products, there is no warranty for the complete system.

Repairs should be carried out only at our works. If any information is missing or unclear, please contact the ipf electronic gmbh.

**2. Identification**

**Magnetic strip:** The magnetic strip with the article no. AM000069 has a width of 20mm.

**Magnetic sensor:** The device type with the article no. you can find on the label.

### 3. Installation

For mounting, the degree of protection specified must be observed. Protect the unit, if necessary, against environmental influences such as sprayed water, dust, knocks, extreme temperatures.

**Attention!** When mounting sensor and magnetic strip please observe that both components are correctly aligned and that the mounting tolerances are respected (see fig. 7).

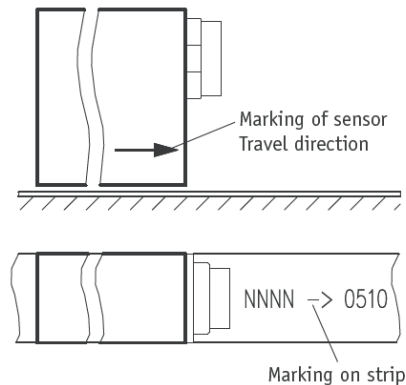

Fig. 1: Alignment

#### 3.1 Mounting the magnetic strip

The mounting surface/measuring track must be flat. Buckles or bumps will lead to inaccurate measurement results. Please protect the magnetic strip from mechanical damage (e.g. against shocks and vibration).

For technical reasons the strip should be approx. 85mm longer than the actual measuring distance.

**Attention!** To guarantee **optimal adhesion**, oil, grease dust etc. must be removed by using cleansing agents which evaporate without leaving residues. Suitable cleansing agents are e.g. ketones (acetone) or alcohols; the companies Loctite and 3M can both supply such cleansing liquid. Make sure that the surface to be glued is dry and apply the strip with maximum pressure. Glueing should preferably be carried out at temperatures between 20°C to 30°C and in dry atmosphere.



**Advice:** When applying long pieces of magnetic strip do not immediately remove the complete protective foil, but rather peel back a short part from the end sufficient to fix the strip. Now align the strip. As the protective strip is then peeled back and out press the tape firmly onto the mounting surface. A wall paper roller wheel could be used to assist in applying pressure onto the magnetic strip when fixing it in position).

#### Mounting steps

- Carefully clean the mounting surface (1).
- Remove protective foil (2) from the adhesive side of the magnetic tape (3).
- Stick down the magnetic strip (4).
- Carefully clean the surface of the magnetic strip.
- Remove the protective foil (6) from the adhesive tape on the cover strip (5).
- Fix cover strip (both ends should slightly overlap).
- Also fix cover strip's ends to avoid unintentional peeling.

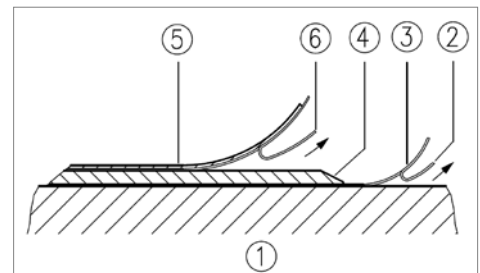

Fig. 2: Mounting the magnetic strip

**Attention!** Do not expose the magnetic strip to magnetic fields. Any direct contact of the magnetic strip with magnetic fields (e.g. adhesive magnets or other permanent magnets) is to be avoided. The same applies to the sensor during operation.



**Mounting examples**

Mounting with chamfered ends (fig. 3) is not recommended unless the strip is installed in a safe and protected place without environmental influences. In less protected mounting locations the strip may peel. There we recommend mounting accord. to fig. 4 and fig. 5.

Mounting in a groove (fig. 6) best protects the magnetic strip. The groove should be deep enough to totally embed the magnetic strip.

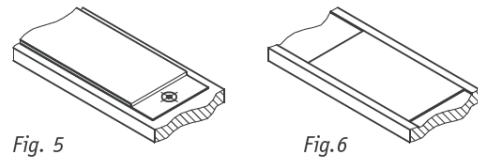
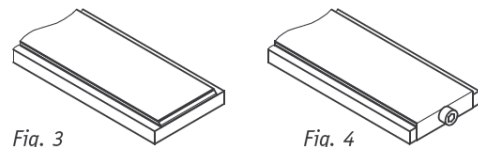

**3.2 Mounting the magnetic sensor**

When mounting the magnetic sensor, ensure that the arrow on the sensor heads in the same direction as the arrows on the magnetic strip (fig. 1).

The sensor's position relative to the magnetic strip is exactly defined. The correct gap between sensor and magnetic strip must be maintained over the total travel distance, irrespective whether the strip or sensor moves (fig. 7).

Within the defined limits (fig. 7), errors due to deviation are less important than errors resulting from strip and sensor tolerances.

The max. allowable distance between sensor and magnetic strip (without cover strip) is 1mm. When using a cover strip, the gap is reduced by the thickness of the cover strip including its adhesive tape. The Sensor must not touch the magnetic strip.

An accumulation of the different possible mounting tolerances should be avoided.

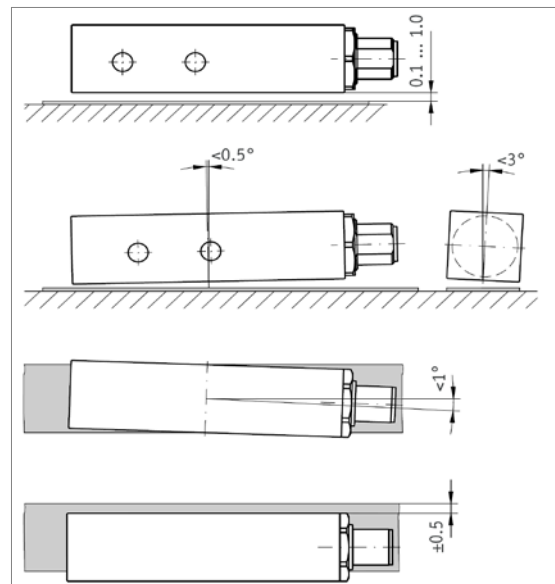

Fig. 7: Mounting tolerances

**4. Electrical connection**

- Switch power off before any plug is inserted or removed!!
- Wiring must only be carried out with power off!
- Provide stranded wires with ferrules!
- Check all lines and connections before switching on the equipment.

**Interference and distortion**

All connections are protected against the effects of interference. The location should be selected to ensure that no capacitive or inductive interferences can affect the encoder or the connection lines! Suitable wiring layout and choice of cable can minimize the effects of interference (e.g. interference caused by SMPS, motors, cyclic controls and contactors).

**Necessary measures:**

- Only screened cable should be used. Screen should be connected to earth at both ends. Cross section of the lines 0,25mm<sup>2</sup>
- Wiring to screen and to ground (0V) must be via a good earth point having a large surface area for minimum impedance.
- Contactor coils must be linked with spark suppression.

Power supply: 10 ... 30V DC

Power consumption: < 3W

**4.1 Pin assignment**

PIN	color	Signal	
		SSI (RS422)	RS485
1	white	Zeroing/Config.	Calibration
2	brown	+U <sub>B</sub>	+U <sub>B</sub>
3	green	Data+	DÜA
4	yellow	Data-	DÜB
5	gray	GND	GND
6	pink	Cycle+	N.C.
7	blue	Cycle-	N.C.
8	red	N.C.	N.C.

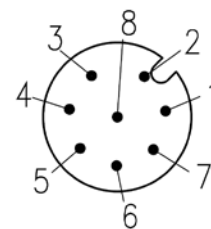

Viewing site = Plug-in side

The connection is made via an 8-pin M12-cable socket, e.g. VK205A25.

## 5. Commissioning

After mounting tape and sensor and after correct wiring, the system is ready for use. Alignment of sensor and tape is carried out by the manufacturer before the material leaves the factory.

Input Zeroing/Configuration serves for determining whether the SSI or RS485 output is active. Simultaneous operation of the two output circuits is not possible! The output circuit is adjusted while the operating voltage is being switched on, and it is controlled during the time of switching on via the assignment of the "zeroing/configuration" input.

Output circuit	Assignment input Zeroing / Configuration
RS485	+U <sub>B</sub> (24VDC)
SSI	GND

**Attention!** The input should never be operated open to avoid potential interferences.

The "zeroing / configuration" input can be used for calibrating during SSI operation. For this purpose, this input must be applied to the operating voltage +UB for at least 2 seconds.

In the RS485 operation mode, various parameters besides the position value can be read out and/or modified.

It is recommended to operate the device with the SSI-interface with the display devices WP054900 or WP054905! (Adjustment 25 bits, hi bit:24, lo bit: 02)

### 5.1 SSI-interface

The integrated SSI-interface of the MW208120 allows a synchronous output of the position value. Its data format comprises a width of 24 bit which are either issued as Gray or binary codes. All following bits (25, 26...) are issued as "0". Operation with the WP054900 and WP054905 is possible.

Data and cycle signals correspond to RS422. The typical SSI monoflop time is 20...25µs, which gives a min. cycle rate of 62.5kHz.

Cable length 10m: max. cycle rate 800kHz

Cable length 100m: max. cycle rate 250kHz

Cable length 200m: max. cycle 125kHz

Please note that the possible max. cycle rate and data integrity mainly depend on the length of the connection line.

### 5.2 Zero-setting

- a) SSI operation: Activate the zeroing input (see chapter 4.1) with +24VDC (for more than 2 seconds).
- b) RS 485: By interface command „I“ (see chapter 8)

## 6. Maintenance

We recommend cleaning the magnetic strip's surface from time to time with a soft cloth in the event of heavy soiling caused by dust, chips, humidity, etc.

## 7. Trouble shooting

Below there are some typical errors which may occur during installation and operation:

- Sensor not or incorrectly connected (for pin connection see chapter 4).
- Tolerance for the gap between magnetic sensor and magnetic strip not observed over the total travel distance. Sensor touches strip (see fig. 7).
- Counter able squeezed / interrupted / cut by sharp edges.
- Sensor's active side not mounted towards the magnetic strip (see fig. 7).
- Sensor and magnetic strip have been incorrectly aligned (see chapter 1).
- Magnetic fields near the measuring surface distort the measuring values. If required, provide for adequate screening.
- Wrong measuring values due to EMC interferences (see chapter 4).

## 8. List of commands / service modes

Parameters: 4800 (default) ... 115200 Baud, no parity, 8Bit, 1 start bit, 1 stop bit

Data code: ASCII (unless specified differently)

Value range: 2/3 Byte: 0...65535 / 0...± 223

The standard mode serves for test purposes, automatic configuration, and for computer coupling. Via the RS232 serial interface, the MW208120 can be operated directly from a computer or terminal. The interface must have the following settings:

4800 baud, no parity, 8 bit word length, 1 start bit, 1 stop bit, no handshake.

Generally, the PC (or the terminal) sends an uppercase letter, together with additional parameters, if required. The MW208120 sends a reply with a concluding <CR>.

Command	Length	Reply	Description
a0	2/8	"MSA510/1>"	Device type / software
a1	2/7	"V0.03>"	Software version
b	1/8	"012345"	non-offset band value
cxy	3/5	"3f0b"	Read out EEPROM values Hex-ASCII; xy 00 ... 63 dec
dxyklmn	7/2	">"	Write EEPROM cell Hex-ASCII; xy 00 ... 63 dez, klmn = Hex-ASCII
ey	2/10	"+xxxxxxx>"	Issue parameter y = address (0...3) x = decimal value y = 0: position value y = 1: zero position value y = 2: calibration value y = 3: range limit
fy+xxxxxxx	10/2	">"	Enter parameter y = address (1...3) x = decimal value (±0...9999999) y = 1: zero position value (de-fault=0) y = 2: calibration value (de-fault=0) y = 3: range limit (default=0)
g	1/9	"0/ 10>"	Read out resolution Here: 10mm
hx	2/2	">"	Write resolution (non-volatile): x = 0: 10mm x = 1: 1mm x = 2: 0.1mm x = 3: 0.01mm x = 4: 1i x = 5: 0.1i x = 6: 0.01i x = 7: 0.001i
i	1/8	"Adr.23>"	Send SIKONETZ3-address (de-fault 01)
jxy	3/2	">"	Hand over SIKONETZ3-address (2-digit, eg. 03)
k	1/-	" "	Software-RESET
l	1/2	">"	Zero-setting
nx	2/2	">"	Write output code; 0 = Gray 1 = Binary
p	1/4	"0x>"	Device status (for internal purposes)
q	1/8	"004800"	Read out baudrate
r	1/2	">"	Start alignment (only for use in our factory!)
s	1/2	">"	Set device to original state; default values (alignment is retained!): counting direction: upward code: gray-code zero-point value: 0 resolution: 0.01mm
tx	2/2	">"	Write counting direction (non-volatile) x=0: upward x=1: downward
ux	2/2	"xy"	Read out internal values (only for use in our factory!)
vklnop	7/2	">"	Write baudrate (volatile) "klmnop": 004800, 009600, 019200, 038400, 057200 or 115200
w	1/3	"xyz"	Read out hexadecimal position value
y	1/6	"0x3b>"	Read out flag register (for internal purposes)
z	1/10	"+1234567>"	Read out ASCII position value

**9. Technical data**

**9.1 Sensor MW208120**

operating voltage $U_B$	10 ... 30V DC, reverse polarity protected
current consumption	< 125mA
type of output	SSI
clock-pulse rate	<500kHz
cycle period	<650µs
resolution	0.01mm
system accuracy	$\pm (0.05 + 0.03 \times L)$ mm (L in m)
repeat accuracy	max. 0.01mm
distance sensor / strip	max. 1mm
linear traverse speed	max. 5m/s
housing	aluminum
ambient temperature	0 ... 60°C
humidity	100% rF, condensation permitted
vibration resistance	10g / 50Hz
safety class	3 acc. to IEC 801
protection class	IP65 acc. to EN60529
max. measuring length	5120mm
connection	M12-connector, 8-pin (suitable cable socket e.g. VK205A25)

**Dimensional drawing**

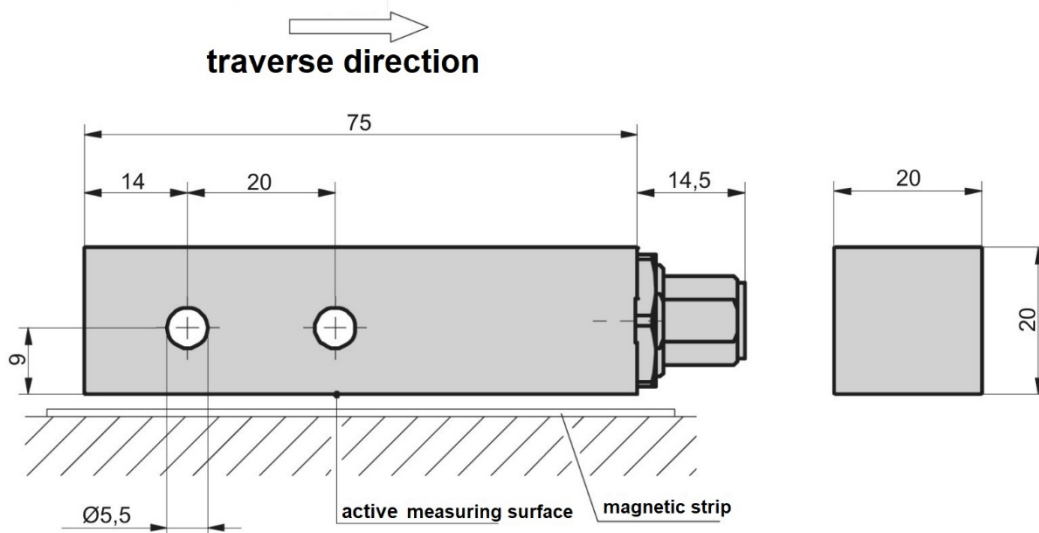

**9.2 Magnetic strip AM000069**

strip length	max. 5120mm
strip width	20mm
thickness	1.4mm w/o cover strip
accuracy class	±50µm at 20 °C
temperature coefficient	(11±1) x 10 <sup>-6</sup> /K
operating temperature	-20 ... +70 °C
storage temperature	-40 ... +70 °C
air humidity	100 % rF, condensation permitted
mounting	adhesive bond, pre-mounted double-sided adhesive tape
material cover strip	stainless steel

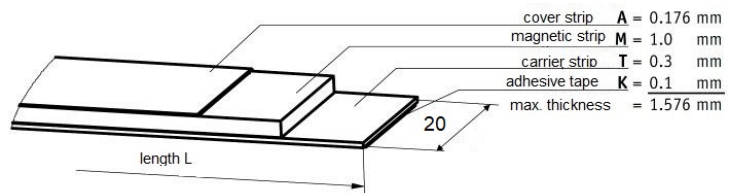

**Safety warning:** Never use these devices in applications where the safety of a person depends on their functionality.