

OL10034x / OL10134x

Table of contents

Product description.....	page 2
Safety instructions for the amplifier OL10.....	page 2
Safety instructions for plastic fibre optics.....	page 2
Technical data.....	page 3
Mounting the amplifier.....	page 4
Removing the amplifier.....	page 4
Connection of the fibre optics.....	page 4
Electrical connection.....	page 4
Cascading amplifiers.....	page 5
Part description.....	page 6
Wiring diagrams.....	page 6
Main functions and basic settings.....	page 7
Limit Teaching.....	page 8
2-Level Teaching.....	page 9
Fine adjustment.....	page 10
Output mode (light-on / dark-on).....	page 11
Timer function.....	page 12
Programming mode PRO.....	page 13
PRO 1.....	page 13
PRO 2.....	page 15
PRO 3.....	page 15
PRO 4.....	page 16
PRO 5.....	page 16
Error indication.....	page 17
Code setting table.....	page 17

Product description

The OL10 series are amplifiers for plastic fibre optics. The adjustment is carried out by the **Jog-switch** and the **Mode** pushbutton. Fine adjustment can be done in the **PRO** mode.

Safety instructions for the amplifier OL10

- Make sure to carry out the wiring in the power supply off condition.
- Verify that the supply voltage variation is within the rating.
- Take care that if a voltage exceeding the rated range is applied, or if an AC power supply is directly connected, the sensor may get burnt or damaged.
- In case noise generating equipment (switching regulator, inverter motor, etc.) is used in the vicinity of this product, connect the frame ground (F.G.) terminal of the equipment to an actual ground.
- If power is supplied from a commercial switching regulator, ensure that the frame ground (F.G.) terminal of the power supply is connected to an actual ground.
- Do not use during the initial transient time (0.5 sec.) after the power supply is switched on.
- Make sure to use an isolation transformer for the DC power supply. If an autotransformer (single winding transformer) is used, this product or the power supply may get damaged.
- In case a surge is generated in the used power supply, connect a surge absorber to the supply and absorb the surge.
- Take care that short-circuit or wrong wiring of the load may burn or damage the sensor.
- Do not run the wires together with high-voltage lines or power lines or put them in the same raceway. This can cause malfunction due to induction.
- Make sure to use the optional quick-connection cable for the connection of the amplifier. Extension up to total 100m is possible with 0.3mm², or more, cable. However, in order to reduce noise, make the wiring as short as possible.
- Take care that the sensor is not directly exposed to fluorescent light from a rapid-starter lamp or a high frequency lighting device, as it may affect the sensing performance.
- This sensor is suitable for indoor use only.
- Avoid dust, dirt, and steam.
- When the fiber head gets dusty or dirty etc. the sensitivity deteriorates. To keep stable detection, wipe the fiber head to remove dust or dirt etc. and carry out sensitivity teaching periodically.
- Take care that the product does not come in direct contact with organic solvents, such as, thinner etc.
- This sensor cannot be used in an environment containing inflammable or explosive gases.
- Never disassemble or modify the sensor.

Safety instructions for fibre optics

- Take care that the product does not come in direct contact with organic solvents, such as, thinner etc.(except for chemical resistant fibres)
- Avoid strong traction on the fibre optics.
- Please use a soft cloth for cleaning the detecting surfaces only.
- The bend radius may be 25mm minimum. Exceeding the minimum bend radius will cause the light level within the fibre to dim. For fibres with smaller bend radiuses than 25mm please note the stated value.
- When cutting the cuttable fibres please do use the suitable fibre cutter AL000007. Double coated fibres must not be cutted at the double coated areas.
- Note: Do only cut one fibre at a time. Do not use the cutter twice.
- The bend radius of metal coated sensing heads must be 10mm minimum. (Please note that the coating of fibres with angular sensing head, fibres with small beam angles and fibres with extremely small diameters are not bendable).
- The fibre adapters for the confectionable fibres are part of the delivery. Please do use the shorter one.

- Please avoid the influence of fluorescent light of lamps with starters, or devices which emit high frequent light. This causes an influence for the sensing range.
- The mounting torque must not exceed the values mentioned in the table below.

mounting with nut		mounting with M3-screw		mounting with adjusting screw	
M3	0,39Nm	LS207018	0.58Nm	LS207208 / LT107205	0.20Nm
M4	0,58Nm	LT207020		LS207002	0.19Nm
M5	0,98Nm			LS107015 / LS207016 LS207014 / LT207016	0.19Nm (range 10mm)
M6	0,98Nm			LT207015	0.34Nm (range 7mm)
M14	1,47Nm			others	0.29Nm

Technical data

article-no.	OL100340 (red light) OL100341 (blue light) OL100342 (green light) OL100343 (infrared light)
response time	0,065 / 0,15 / 0,25 / 2ms programmable
timer functions	rise delay-, decay delay time, one-Shot 0.5 to 500ms adjustable
current consumption	< 40mA
voltage drop	< 2.5V
operating voltage	12 to 24V DC ± 10%
max. current load	100mA (when cascading more than 5 devices 50mA)
switching output	pnp, no/nc programmable
sensing range Sn	depending on the fibre optic used
hysteresis	programmable in 3 ways
digital display	4 digit, 7-segment red LED
status display	orange LED
stand-by function display	green LED (glows when status is stable)
MODE-display	run: green LED, all other functions yellow LED
data transmission	via infra red window, max. 16 amplifiers
material	housing: ABS / coverage: polycarbonate / switch: acrylic
system of protection	IP 40
ambient temperature	-10 °C to +55 °C
electrical connection	connector, matching cable, see list of articles
transmitting element	modulated LED, see list of articles
cable socket 3 wires (master)	2m: AL000013 5m: AL000014
cable socket 1 wire (slave)	2m: AL000017 5m: AL000018
accessories	standard rail AL000015 reduction sleeve AL000016

Mounting the amplifier

1. Fit the rear part of the mounting section of the amplifier on a 35mm width DIN rail.
2. Press down the front part of the mounting section of the amplifier on the 35mm width DIN rail.

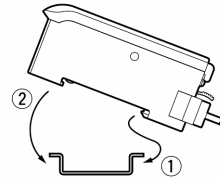

Removing the amplifier

1. Push the amplifier forward.
2. Lift up the front part of the amplifier to remove it.

Note: Take care that if the front part is lifted up without pushing the amplifier forward, the hook on the rear portion of the mounting section is likely to break.

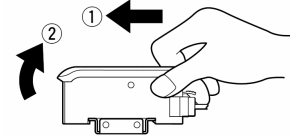

How to connect the fibre cables

1. Snap the fibre lock lever down.
2. Insert the fibre cables slowly into the inlets until they stop. (note 1)
3. Return the fibre lock lever to the original position, until it stops.
4. Snap the fibre lock lever up again.

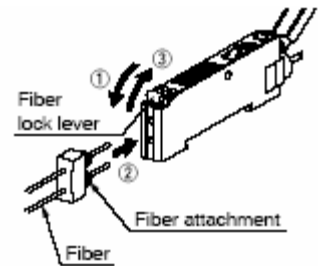

Note: In case the fibre cables are not inserted to a position where they stop, the sensing becomes unstable.

Electrical connection

Connection method

1. Holding the connector of the quick-connection cable, align its projection with the groove at the top portion of the amplifier connector.
2. Insert the connector till a click is felt.

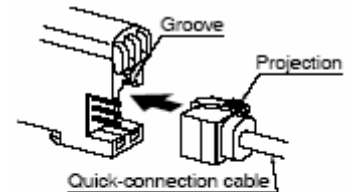

Disconnection method

Pressing the projection at the top of the quick connection cable connector, pull out the connector.

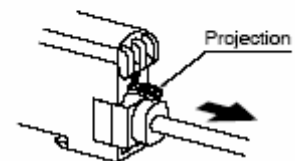

Note: Take care that if the connector is pulled out without pressing the projection, the projection may break. Do not use a quick-connection cable whose projection has broken. Further, do not pull by holding the cable, as this can cause a cable-break.

Cascading amplifiers

- A Make sure to add or remove the amplifiers in the power supply off condition.
- Make sure to check the allowable ambient temperature, as it depends on the number of amplifiers connected in cascade.
- In case two, or more, amplifiers are connected in cascade, make sure to mount them on a DIN rail.
- When connecting in cascade, mount the amplifiers close to each other, fitting them between the optional end plates mounted at the two ends. SUB mode can be set.
- Up to maximum 15 amplifiers can be added (total 16 amplifiers connected in cascade).
- When connecting more than two amplifiers in cascade, use the sub cable AL000017 (2m) or AL000018 (5m) as the quick-connection cable for the second amplifier onwards.

Cascading method

1. Mount the amplifiers, one by one, on the 35mm width DIN rail. (For details refer to „**Mounting the amplifier**“.)
2. Slide the amplifiers next to each other, and connect the quick-connection cables.
3. Mount the optional end plates at both the ends to hold the amplifiers between their flat sides.
4. Tighten the screws to fix the end plates.

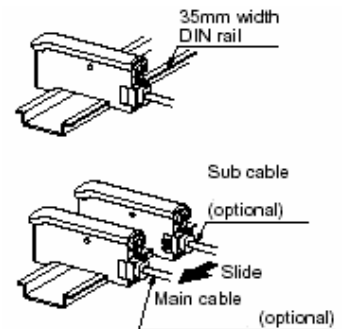

Dismantling method

1. Loosen the screws of the end plates.
2. Remove the end plates.
3. Slide the amplifiers and remove them one by one. (For details, refer to „**Removing the amplifier**“.)

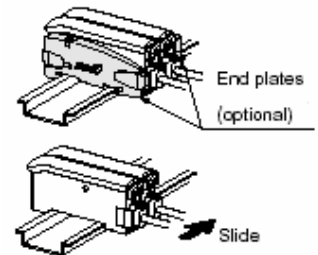

Part description

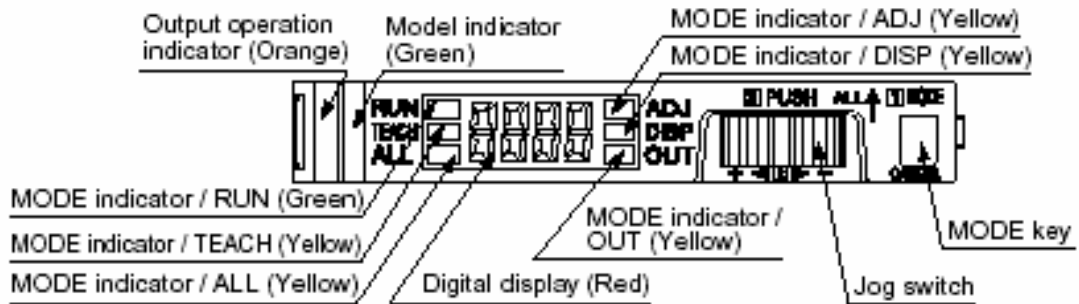

I/O Circuit Diagrams

PNP output type

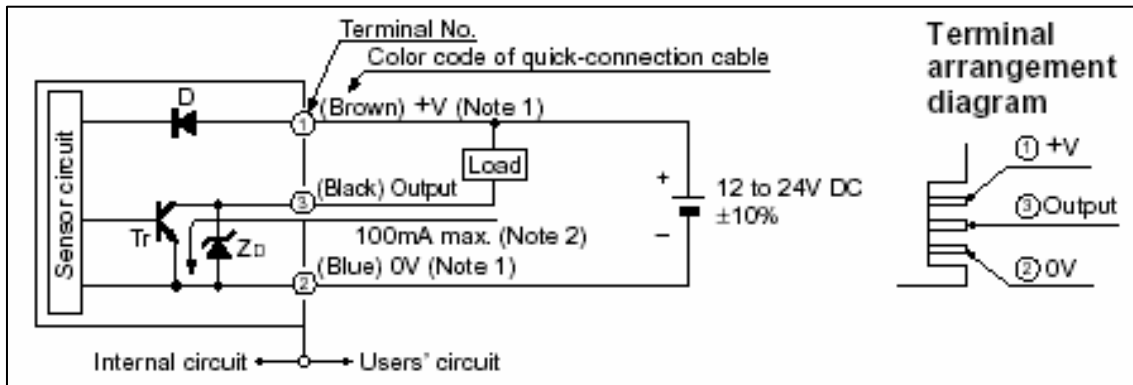

NPN output type

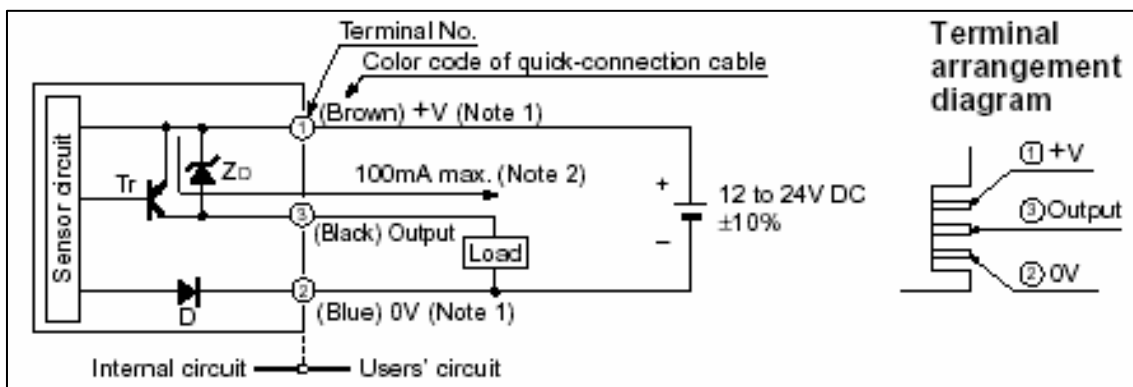

- Symbols:** D1, D2: Reverse supply polarity protection diode
 ZD1, ZD2: Surge absorption zener diode
 Tr: PNP- / NPN output transistor

Note 1: The quick-connection sub cable does not have +V (brown) and 0V (blue). The power is supplied from the connector of the main cable.

Note2: 50mA max. if five, or more, amplifiers are connected together.

Main functions and basic settings

Each mode can be selected using the large MODE key. Detailed functions and settings can be chosen using the large jog switch.

RUN – mode

The received light intensity is displayed (range 0 to 4000)



TEACH – mode

The threshold values can be set by either 2-level teaching or limit teaching, when the MODE indicator / TEACH (yellow) lights up.

Page 8

1. limit teaching

This is the method of setting the threshold value by teaching only the object absent condition (stable incident light condition). This is used for detection in the presence of a background body or for detection of small objects.

2. 2-level teaching

This is the method of setting the threshold value by teaching two levels, corresponding to the object present and object absent conditions. Normally, setting is done by this method.

ADJ : threshold value fine adjustment

If the adjusted threshold does not lead to reasonable results, you can carry out a manual a fine adjustment.

page10

L/D ON : light-on or dark-on mode

Select light-on or dark-on mode.

dark-on: the output switches if the current value is under the threshold.

light-on: the output switches if the current value is over the threshold.

page 11

TIMER : time delay

Enable and disable the time delay function.

page 12

PRO : PRO-Mode

In the PRO-Mode more sensitive detection and fine settings can be performed.

page 13

Limit Teaching

Limit Teaching

Teaches only the status condition in which no sensing object is within sensing range (status in which incident light intensity is stable). This method is used to set a threshold value for conducting sensing in the presence of a background, or when extremely small objects are to be detected.

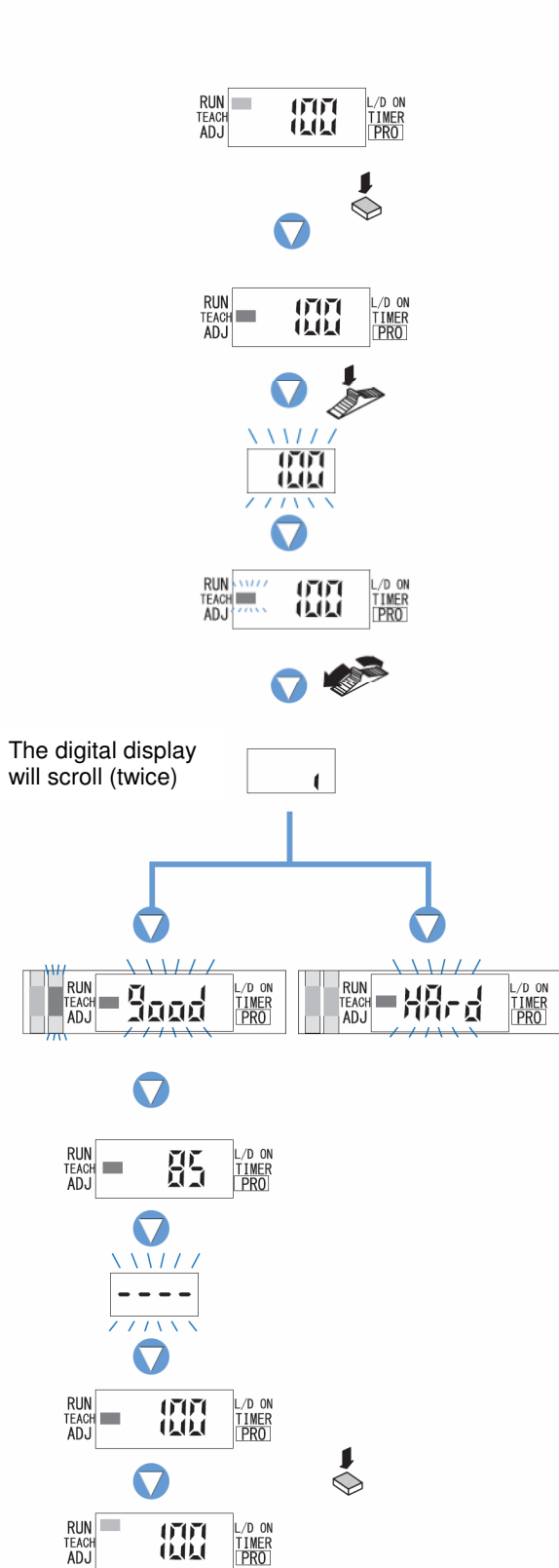

Press the Mode key once to select TEACH mode

Press the JOG switch (absent object)

The digital display will blink and indicate the incident light intensity reading, then the MODE indicator/TEACH (yellow) will blink.

Turn the [Jog switch] in the '+' or '-' direction.

When using thru-beam fibre

If the switch is turned toward the '-' direction, the digital display will Scroll from the left to the right (twice) and the threshold value will be shifted down by approximately 15 %, to a value lower than the incident light intensity reading.

When using reflective fibre

If the switch is turned toward the '+' direction, the digital display will Scroll from the left to the right (twice) and the threshold value will be shifted down by approximately 15 %, to a value lower than the incident light intensity reading.

* The initial factory-set value of the shift amount is approximately 15 %.

The sensing stability status will be displayed.

- When stable sensing can be performed →The digital display will blink the word 'good'.
- When stable sensing cannot be performed →The digital display will blink the word 'hard'.

The 'threshold value' setting will be displayed

The digital display will blink

the incident light intensity will again be displayed, indicating that configuration is now complete.

Press the [MODE key] 5 times or keep it pressed for 2 sec. or more, the amplifier will return to 'RUN mode' (normal sensing operation).

2-level Teaching

2-level Teaching

2-level teaching is a method of setting the 'threshold value' by teaching the amplifier two different status conditions - sensing object present and sensing object absent. The 'threshold value' is usually set using this method.

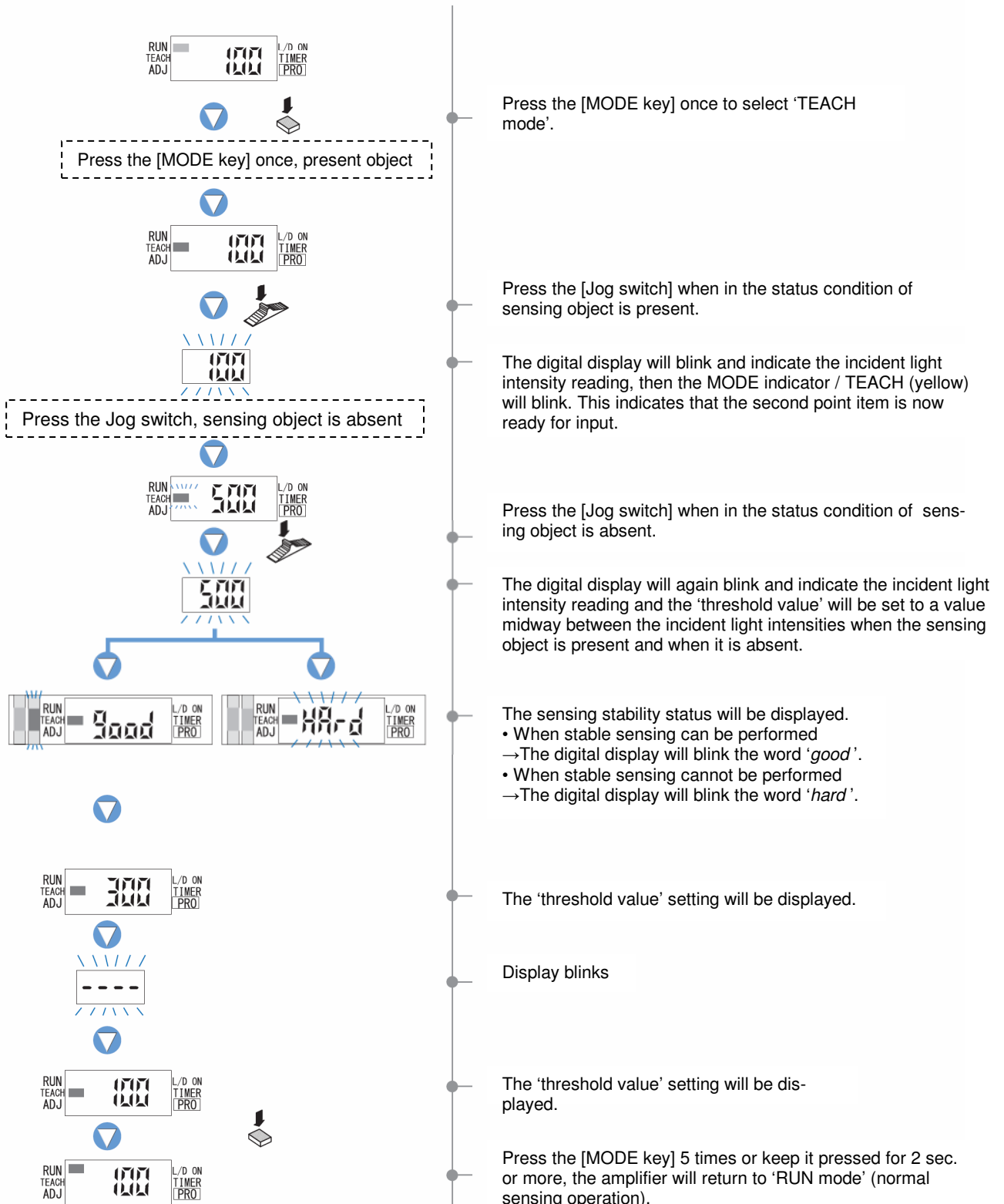

Threshold Value Fine Adjustment Mode (Adjust)

This mode allows fine adjustment of the 'threshold value' setting.

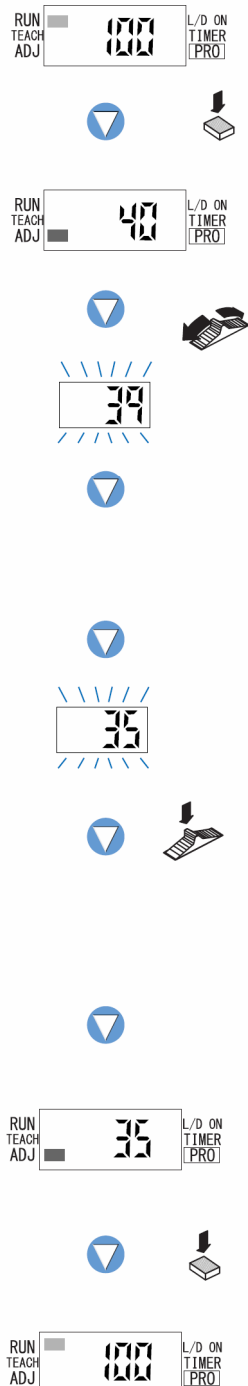

Press the [MODE key] twice to select 'threshold value fine adjustment mode'.

The current 'threshold value' will be displayed.

If the [Jog switch] is turned toward the '+' or '-' direction, the 'threshold value' will change and the new value will blink.

If the [Jog switch] is pressed, the digital display will quickly blink 3 times, confirming the setting of the currently displayed 'threshold value'.

Press the [MODE key] 4 times or keep it pressed for 2 sec. or more, the amplifier will return to 'RUN mode' (normal sensing operation).

Output Operation Setting Mode

This mode allows the selection of output operation from either L-ON (Light-ON) or D-ON (Dark-ON).

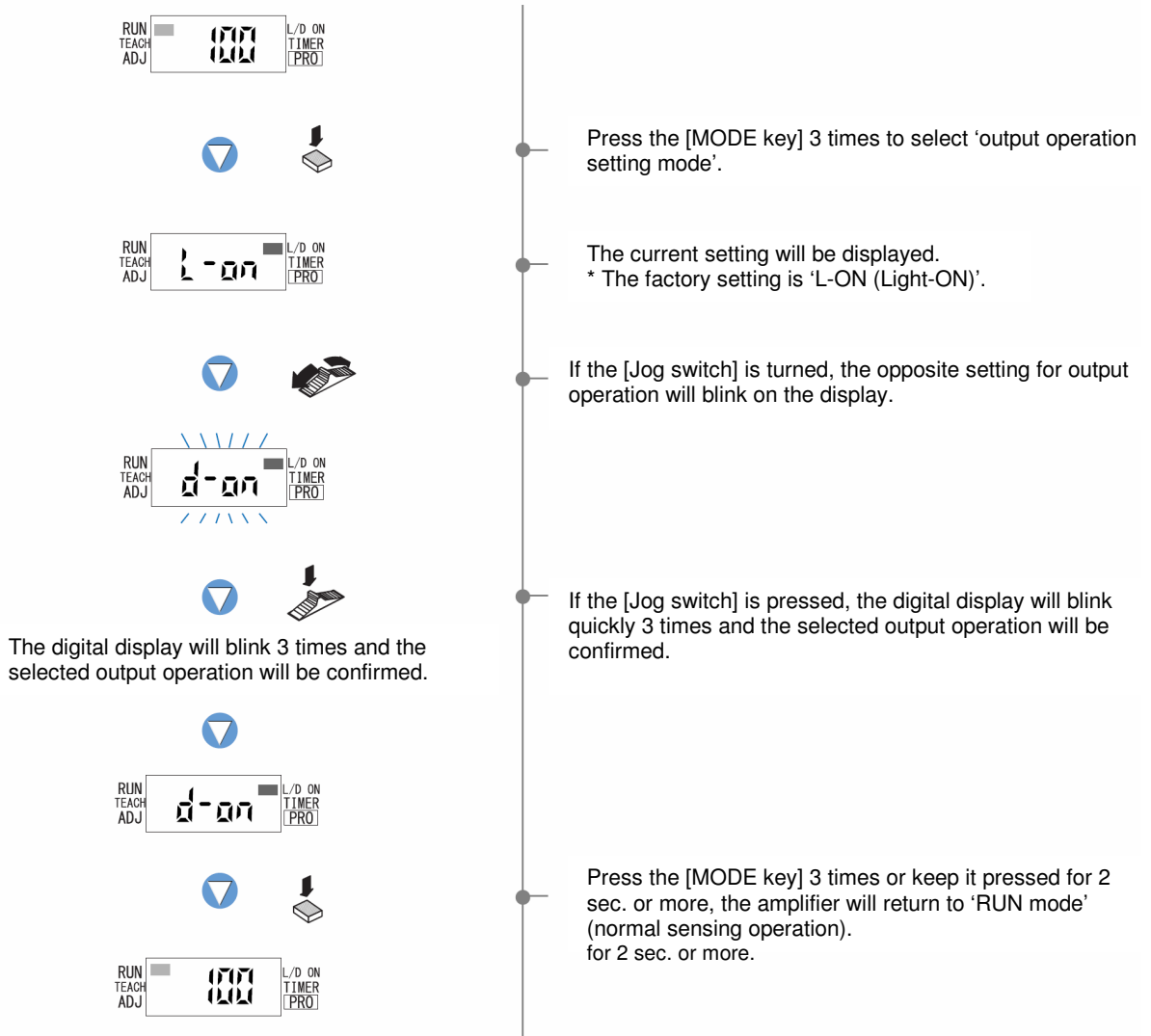

Timer Operation Setting Mode

This mode sets the timer operation. Timer period is set in PRO1 mode.

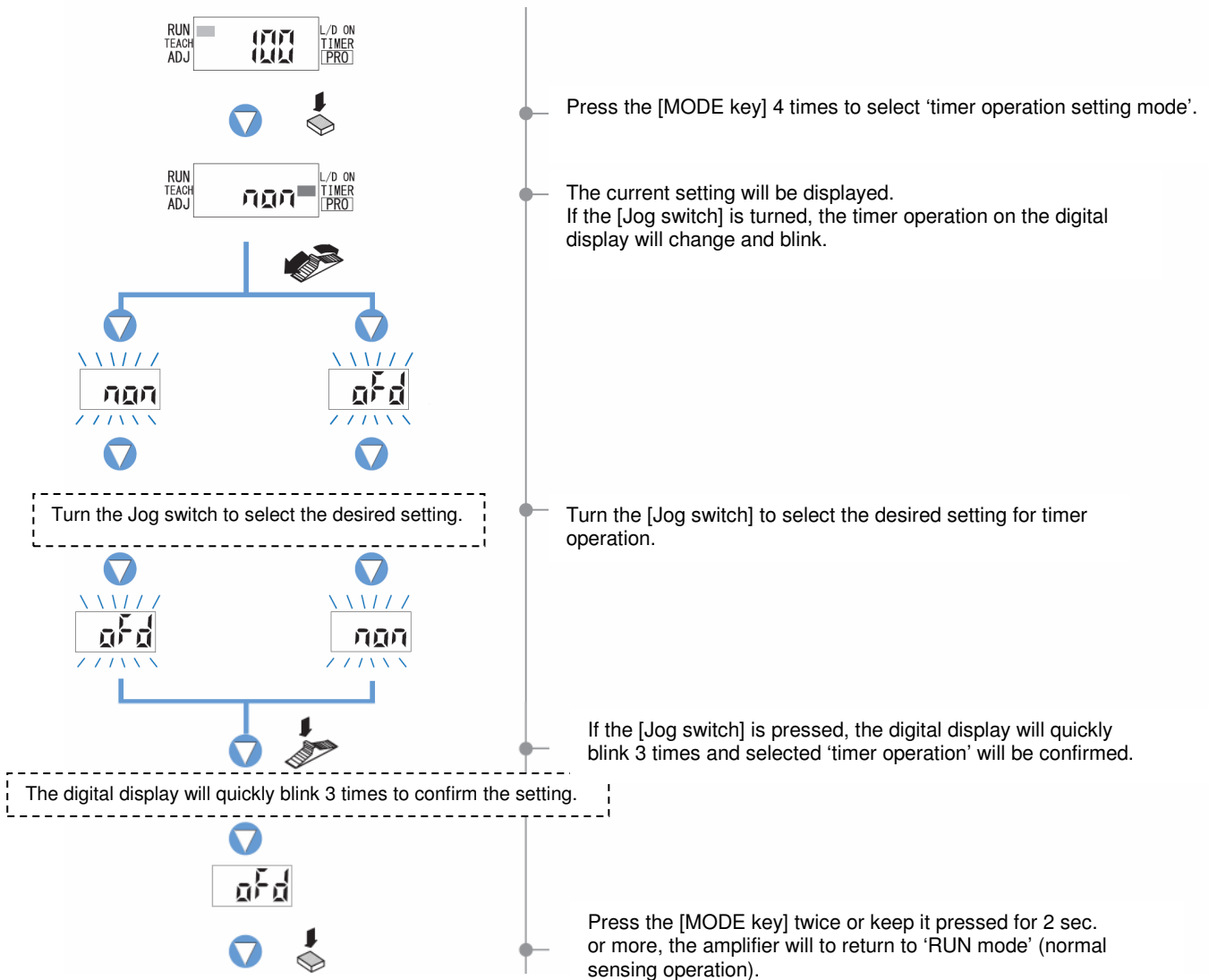

Press the [MODE key] 4 times to select 'timer operation setting mode'.

The current setting will be displayed.
If the [Jog switch] is turned, the timer operation on the digital display will change and blink.

Turn the [Jog switch] to select the desired setting for timer operation.

If the [Jog switch] is pressed, the digital display will quickly blink 3 times and selected 'timer operation' will be confirmed.

Press the [MODE key] twice or keep it pressed for 2 sec. or more, the amplifier will to return to 'RUN mode' (normal sensing operation).

Programming Mode PRO

Pro 1 Mode

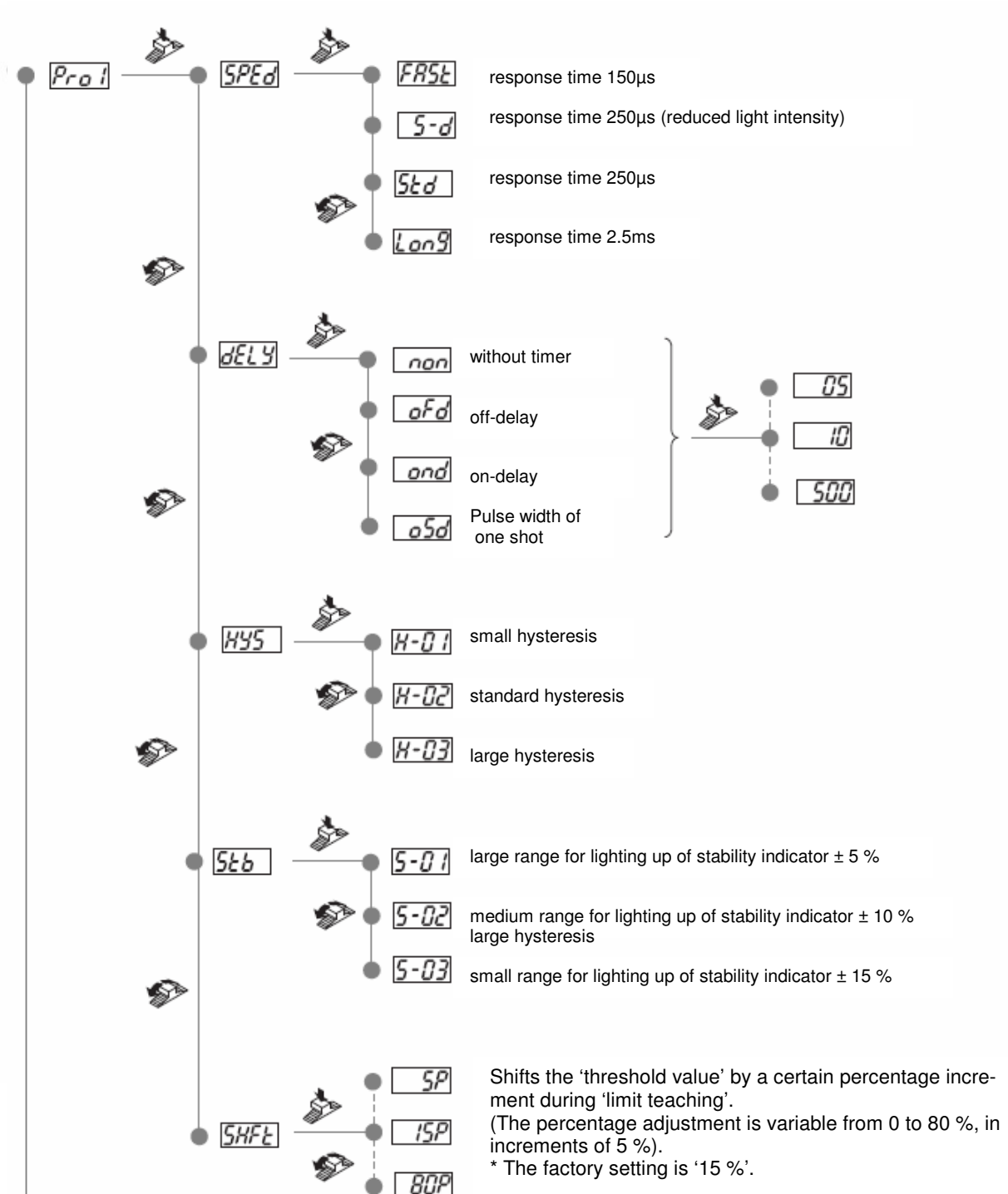

Light Emitting Amount Selection Function

Changes the light emitting amount selection setting.

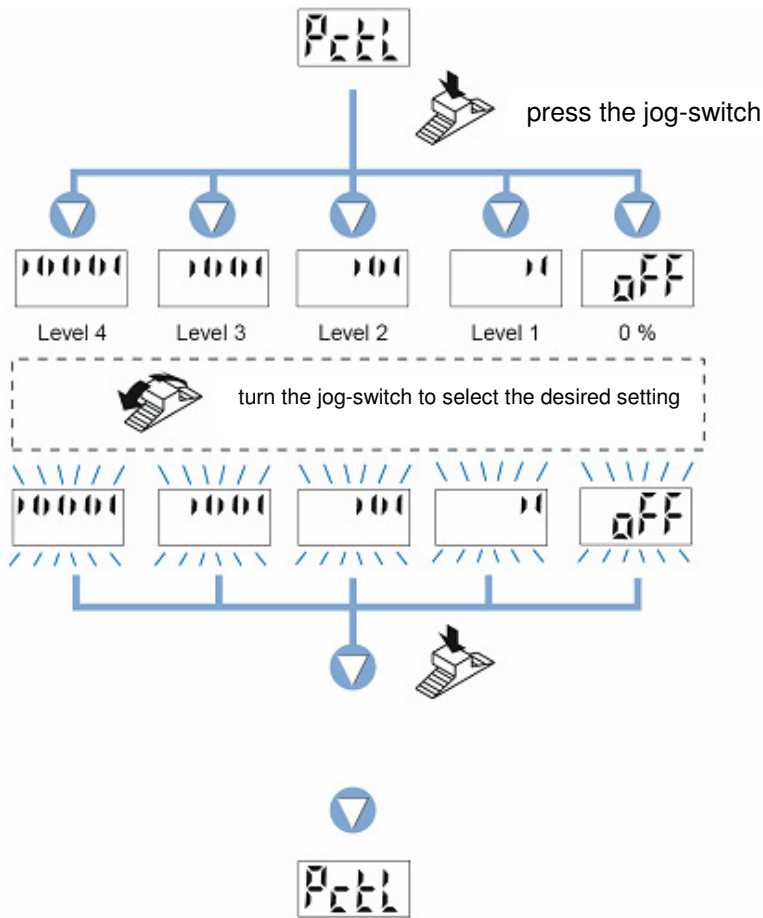

Pro 2 Mode

Digital display setting function

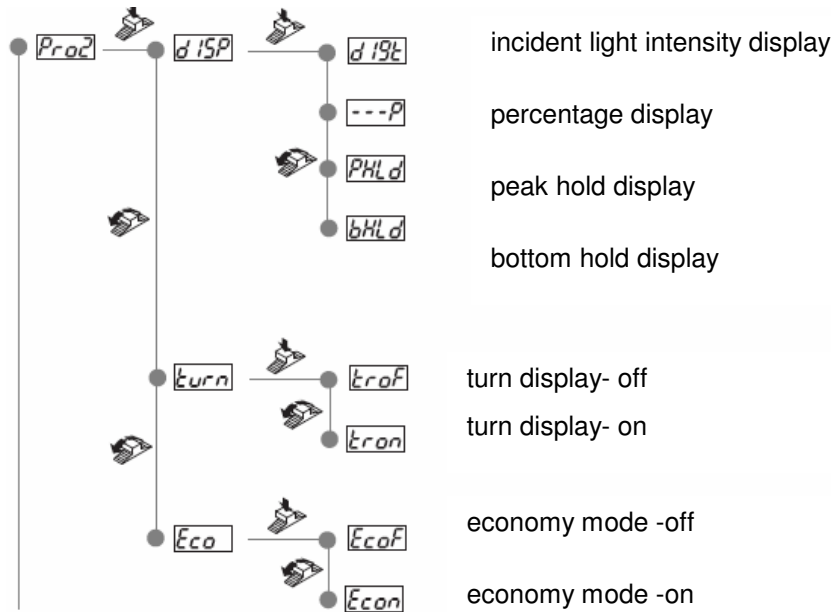

Pro 3 Mode

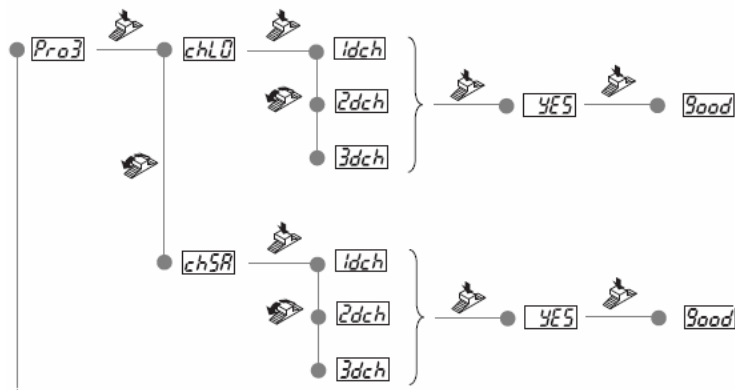

Data Bank Load Setting Function

This function allows configuration settings information from the data bank to be selected and then loaded. This feature allows settings to be changed quickly at times of reconfiguration, etc.

Data Bank Save Setting Function

This function saves amplifier configuration settings. Up to 3 sets of configuration settings information can be saved in '1dch', '2dch' and '3dch'.

Pro 4 Modus

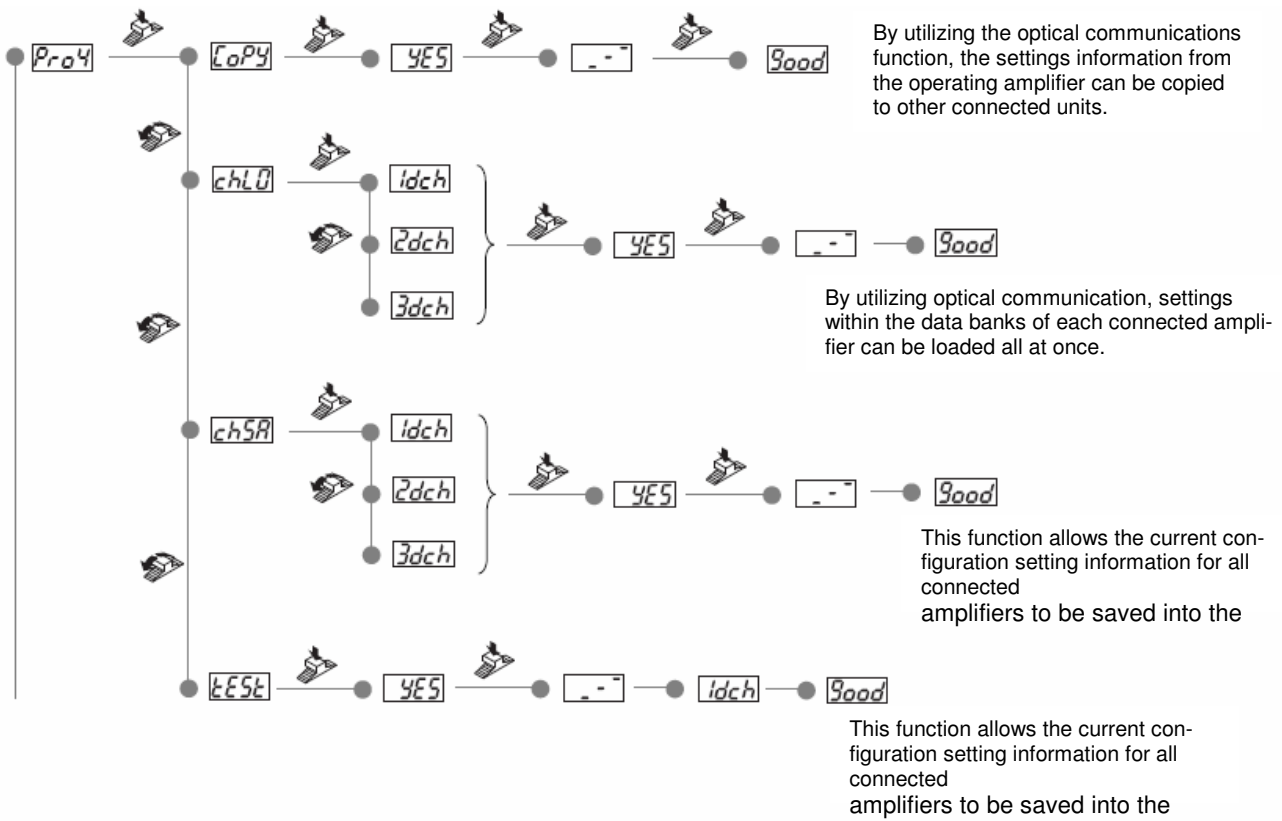

Pro 5 Modus

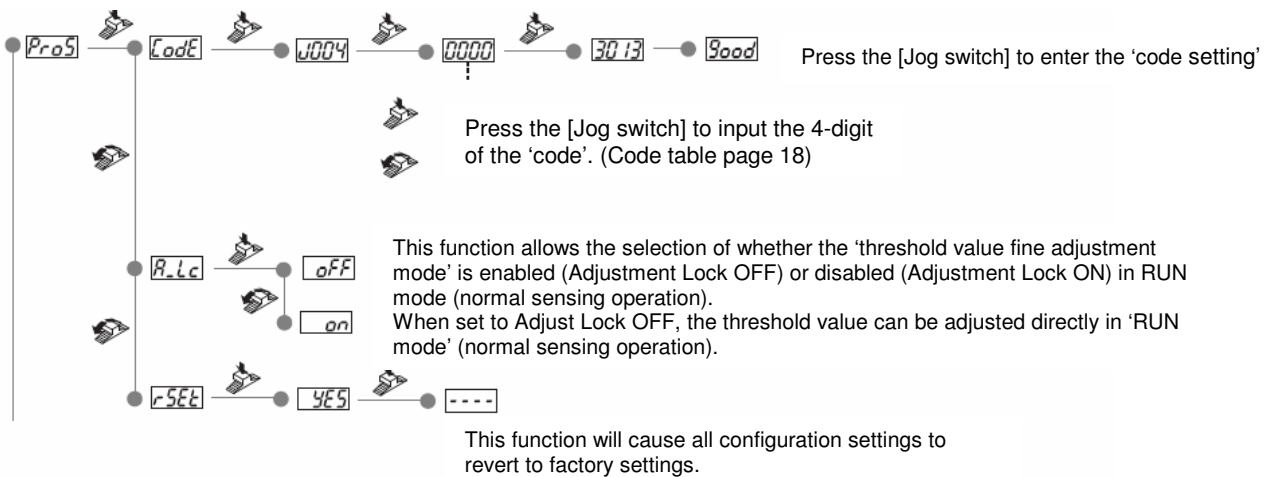

Error indication

FX-301(P)	Error description	Measures
E _r -1	The load has short-circuited and excess current is flowing. E _r 11: Output 1, E _r 12: Output 2	Turn off the power, then check the load.
E _r -5	Communication error has occurred at time of connection. (In case of using functions of PRO4 mode)	Confirm that all amplifiers are properly connected to each other.

Code setting table



First digit				Second digit				Third digit				Fourth digit		
Direct code	Response Time	Hysteresis	Check	Direct code	L-ON / D-ON	Display	Check	Direct code	Adjust lock	Timer operation	Check	Direct code	Timer period	Check
0	STD	H-02 (standard)		0	L-ON	Incident light intensity		0	ON	NON (without timer)		0	OFF	
1	STD	H-03 (large)		1	L-ON	%		1	ON	OFF-delay		1	1 ms	
2	STD	H-01 (small)		2	L-ON	Peak hold		2	ON	ON-delay		2	3 ms	
3	LONG	H-02 (standard)		3	L-ON	Bottom hold		3	ON	ONE SHOT		3	5 ms	
4	LONG	H-03 (large)		4	D-ON	Incident light intensity		4	OFF	NON (without timer)		4	10 ms	
5	LONG	H-01 (small)		5	D-ON	%		5	OFF	OFF-delay		5	30 ms	
6	FAST	H-02 (standard)		6	D-ON	Peak hold		6	OFF	ON-delay		6	50 ms	
7	FAST	H-03 (large)		7	D-ON	Bottom hold		7	OFF	ONE SHOT		7	100 ms	
8	FAST	H-01 (small)						8				8	300 ms	
								9				9	500 ms	