

**OT450520**

operating range **30 ... 600mm**

- ✓ plastic housing, compact design setting
- ✓ by Teach-In
- ✓ LED-display with setting control
- ✓ suppression of reciprocal influence M12-
- ✓ connector, 3-pin



**color independent diffuse reflection sensor with background suppression**

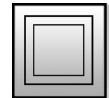

**technical data**

function	background suppression
sensing range	30 ... 600mm
adjustment range	60 ... 550mm
operating voltage	10 ... 30V DC
current consumption (without load)	≤ 30mA
output current (max. load)	≤ 100mA
output signal	push-pull, no/nc
voltage drop	≤ 3V DC
response time / decay time	≤ 0.49msec
sampling frequency	1kHz
transmitting element (pulsed)	LED, red light
wavelength	630nm
short-circuit protection	+
reverse polarity protection	+
operating mode display	LED green
display (signal) / setting control	LED yellow
display (Teach-In)	LED blue
interference suppression	+
housing material	plastic (ASA, MABS)
front screen material	PMMA
protection class (EN60529)	IP67
operating temperature	-25 ... +60°C
connection	M12-connector, 4-pin (pin 2 not connected)

**electric connection**

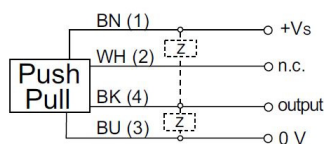

**colours of LED**

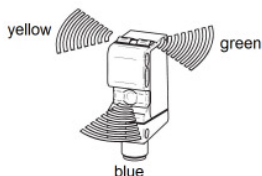

**dim. drawing**

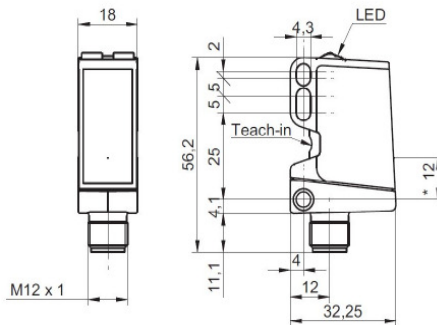

• all dimensions in mm \*transmitter axis

**light beam form**

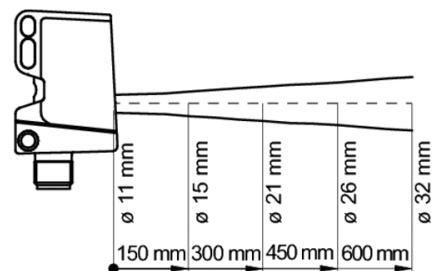

**Teach-in procedure:**

1. Aim the sensor to a reference surface e.g. a reflecting machinepart and make sure that the blue Teach-LED lights.

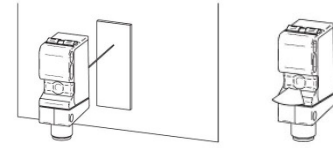

2. Touch the blue Teach-LED which is placed at the rear side of the housing with a ferromagnetic tool for longer than 2sec. but max. 4sec., until all 3 LEDs start blinking with a frequency of 1Hz. The blue Teach-LED flashes stronger once a tool is detected.

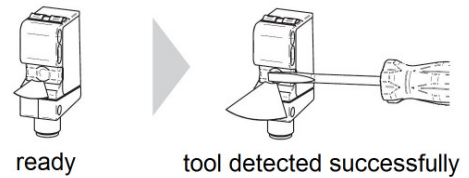

3. Touch the blue Teach-LED again for a short time with a ferromagnetic tool in order to confirm the reference surface.

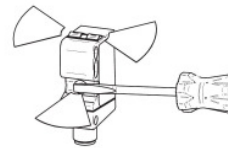

4. The standard configuration of the output is nc (normally closed). It can be changed to no (normally open) by touching the blue LED again for a short time within 4sec. During this time all 3 LEDs are blinking slowly (1Hz).

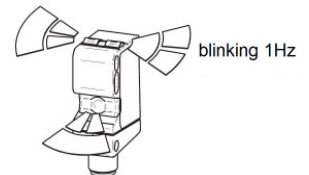

5. As soon as only the blue LED lights, the Teach-In procedure is finished successfully.



If all LEDs blink fast (8Hz), the Teach-In procedure failed and has to be repeated.

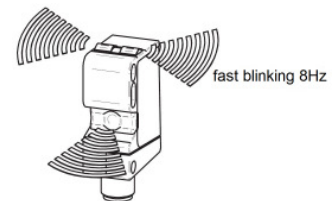

**Note:** The yellow LED indicates the detection of an object, but does not compusary correspond to the switching output. The Teach-In function is active for only 5min. after switching on power.

**Reset to the factory settings**

Touch the blue Teach-LED which is placed at the rear side of the housing with a ferromagnetic tool for 6sec. until all 3 LEDs blink with a frequency of 4Hz and remove the tool immediately. Following the blue Teach-LED should blink normally and the sensor removes to factory settings.

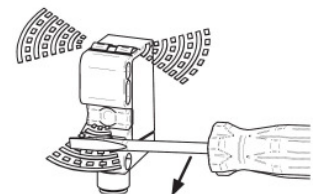

connection: e.g. **VK200025**

mounting bracket: **AY000138**

**Warning:** Never use these devices in applications where the safety of a person depends on their functionality.