

**PT230320**

Laser sensors



- / Plastic housing, compact design
- / Sensing range adjustment via potentiometer
- / PNP switching output
- / M12 connection, 270° rotatable

**Laser protection class 1**  
**Background suppression**

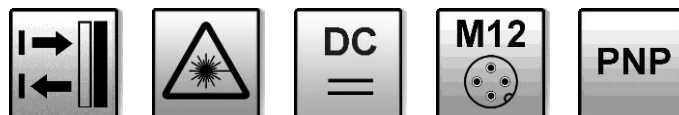

**TECHNICAL DATA**

Function	Triangulation
Sensing range (90% reflectivity)	5 ... 1,000mm
Sensing range adjustment	Potentiometer
Operating voltage $U_B$	10 ... 30V DC
Residual ripple	≤ 10%
Rediness delay	≤ 300ms
Current consumption (without load)	≤ 30mA
Output signal	PNP, no/nc, Setting via control input
Output current (max. load)	100mA
Hysteresis	approx. 12%
Switching frequency	≤ 1,000Hz
Response time	0.5ms
Transmitting element	Laser diode, red light, pulsed
Wavelength	655nm
Laser protection class	1
Short circuit protection	+
Verpolungssicher	+
Display (operation)	LED green
Display (analog output)	LED yellow
Display (soiling)	LED yellow flashing
Housing material	PC-ABS
Front screen material	PMMA
Dimensions	23 x 50 x 50mm
Temperature (operation)	-20 ... +60°C
Schutzart (EN 60529)	IP67 / IP69k
Protection class	M12-connector, 4pin
Connection accessories	e.g. <b>VK200325</b>
Mounting accessories (universal holder)	e.g. <b>AY000119</b>

**Connection**

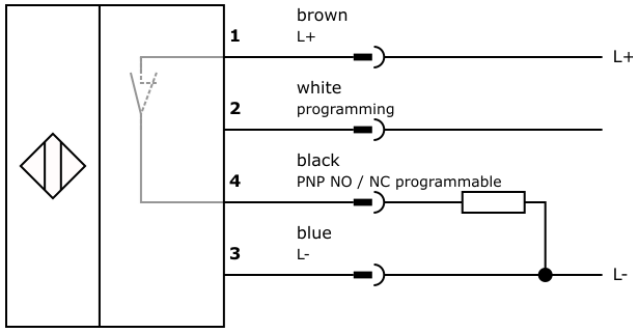

White line on L- or open: Switching output NO  
White line on L+: Switching output NC

**Light spot size**

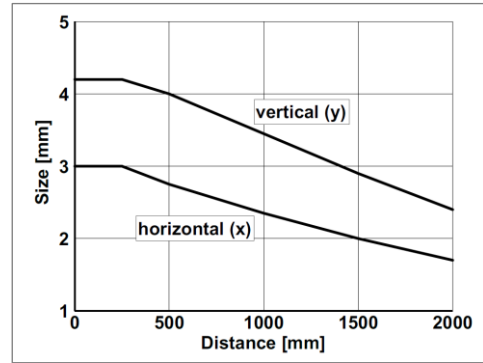

**Dimensional drawing**



**Operating elements**

- 1 = LED yellow (display switching output)
- 2 = LED green (display of operating voltage)
- 3 = Potentiometer
- 4 = Receiver axis (A = 18mm)
- 5 = Transmitter axis (B = 15.6mm)

**Measuring range**

Bezugsmaterial	Erfassungsbereich
Weiß (90%)	5 ... 1000mm
Grau (18%)	10 ... 800mm
Schwarz (6%)	15 ... 700mm

**Adjustment**

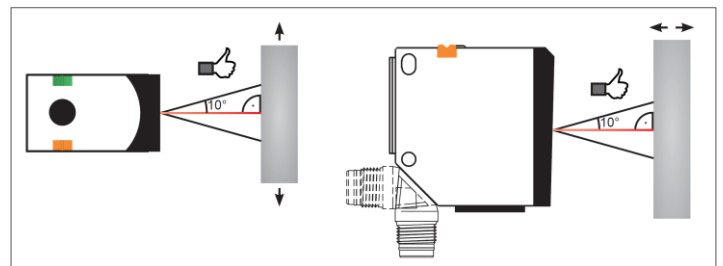

**Safety instructions**

Read the operating instructions before commissioning.

Connection, installation, adjustment and commissioning may only be carried out by qualified personnel.

The use in outdoor areas is not permitted.

Laser protection class 1; divergence angle: 1mrad, wavelength: 655nm; frequency; 7.1kHz, pulse width: 0.2µs; pulse limit: ≤ 140mW (IEC 60825-1).

Complies with 21 CFR 1040.10 and 1040.11 except for deviations as specified in Laser Notice No. 56, May 2019.



**Attention:** Use of controls or adjustments or performance of procedures other than those specified herein may result in hazardous radiation exposure.

Before commissioning, please make sure that all safety instructions in the product documentation, if applicable, have been observed!

The device is not a safety component according to the EU Machinery Directive. The use of this product is prohibited if it has a direct effect on personal safety!

## Intended use

The sensor is used for optical contactless detection.

## Mounting

Mount the sensor with a suitable holder (e.g. universal holder **AY000119**).

## Connection

Install the cable socket in a de-energized state and screw it tight. Connect the cable according to the connection diagram on page 2.

If the white wire (PIN 2) is connected to L- or remains open, the switching output operates as a normally open contact (NO). If the switching output is to operate as a normally closed contact (NC), connect the white wire to L+ (24V). As soon as the operating voltage is applied, the green LED (LED 2) lights up.

## Adjustment

The sensing range adjustment is made with the potentiometer. Turning clockwise increases the sensing distance, turning counterclockwise decreases the sensing distance.

### 1. Object adjustment

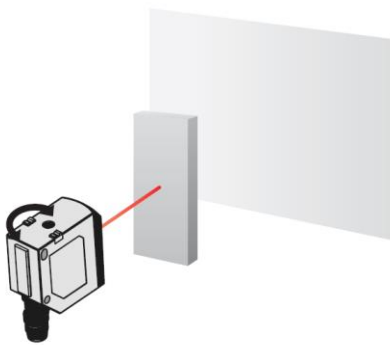

Switching output normally open (NO):  
Turn the potentiometer until the yellow LED lights up.

Switching output normally closed (NC):  
Turn the potentiometer until the yellow

### 2. Background adjustment

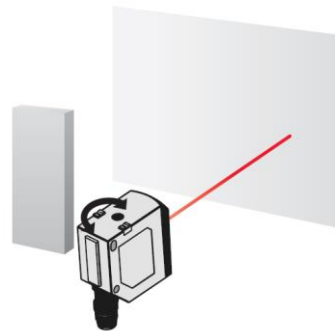

Switching output normally open (NO):  
When looking at the background, the yellow LED must not light up.

Switching output normally closed (NC):  
When looking at the background, the yellow LED must light up.

If necessary, perform fine tuning with the potentiometer.

## Maintenance

The **PT230320** laser sensor is maintenance-free. It is recommended to clean the optical surfaces at regular intervals and to check screw connections and plug connections.