

PT330570

Diffuse reflection sensors



- ✓  **IO-Link**
- ✓ **Plastic housing, compact design**
- ✓ **Setting through teach-in**
- ✓ **LED display with adjustment assistance**
- ✓ **Suppression of mutual influence**
- ✓ **M8 connector 4 pin**

**Laser protection class 1
Background suppression**



Technical data

Function	Background suppression
Sensing distance	15 ... 250mm
Adjustment range	30 ... 250mm
Repeat accuracy	< 0.1mm at laser focus
Operating voltage	11 ... 30V DC
Current consumption (no load)	≤ 30mA
Output power (max. load)	≤ 100mA
Output signal	Push-pull, no/nc
Voltage drop	≤ 2.5V DC
Response time- / decay time	≤ 0.25 ms
Switching frequency	2kHz
Sending element (timed)	Laser diode, red light, pulsed
Optical axis alignment	< 2°
Laser focus distance	80mm
Wavelength	656nm
Short circuit protection	+
Reverse polarity protection	+
Display (operation)	LED green
Display (signal) / adjustment aid	LED yellow
Display (teach)	LED blue
Suppression corrugation	+
Housing material	Plastic (ASA, MABS)
Material of optical surface	PMMA
Degree of protection (EN60529)	IP 67
Temperature (operation)	-10 ... +60°C
Connection	M8-connector 4 pin
Connection accessories	e.g. VK200375
Mounting accessories (universal holder)	AY000118

Electrical connection

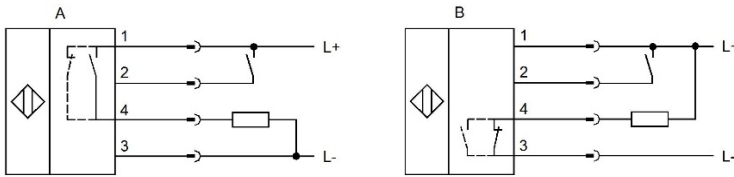

Colours: 1 = BN (brown), 2 = WH (white), 3 = BU (blue), 4 = BK (black)

Function: 1 = L+, 2 = teach-in, 3 = L-, 4 = Push-Pull

In normal operation, the teach-in line (white) must be connected to L- (blue).

Dimensional drawing

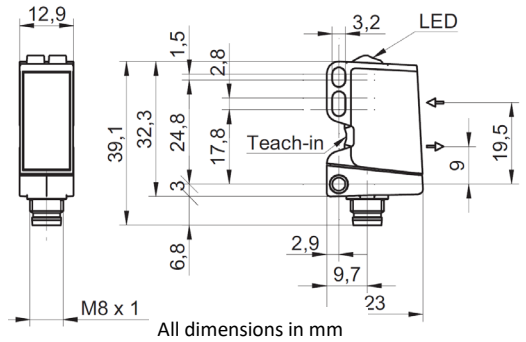

Colours in LED

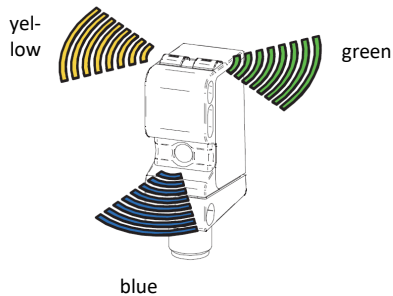

Mounting

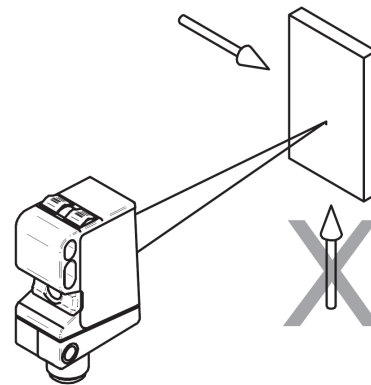

General notes on teach-in:

- The teach-in function locks 5min after switching on.
- In teach mode the output changes to the non-switched state.
- The teach-in process works both with a ferromagnetic tool and via pin 2 of the M8 connector (white wire) by connecting to the operating voltage (+Ub).
- The teach-in via the white wire is not affected by the locking after 5min, therefore the teach line (white) must be connected to 0V (blue) in normal operation.
- With 2-point teach-in, the switching function (light/dark) is set by the sequence of teach-in.
- In normal operation, the yellow LED signals whether an object is detected. This does not automatically correspond to the status of the switching output.

Teach-in procedure for 1 point teach (normal):

1. Make sure that the blue teach LED is on.
2. Touch the blue teach LED at the back of the housing with a ferromagnetic tool for **longer than 2 seconds, but shorter than 4 seconds**, until all 3 LEDs flash at **1Hz**. The blue LED lights up more strongly as soon as a tool is detected.
3. Point the sensor at the object to be detected and quickly touch the blue teach LED with a ferromagnetic tool to confirm the position of the object.
4. If the sensor is to operate as a normally closed contact (output switched off when object is detected), touch the blue teach LED again quickly with a ferromagnetic tool within 4 seconds, otherwise the device operates as a normally open contact.

During this time, all 3 LEDs flash slowly (1Hz).

5. As soon as the blue LED lights up, the teaching process is completed.
6. If all 3 LEDs are blinking fast (8Hz), the teach process has failed and must be repeated.

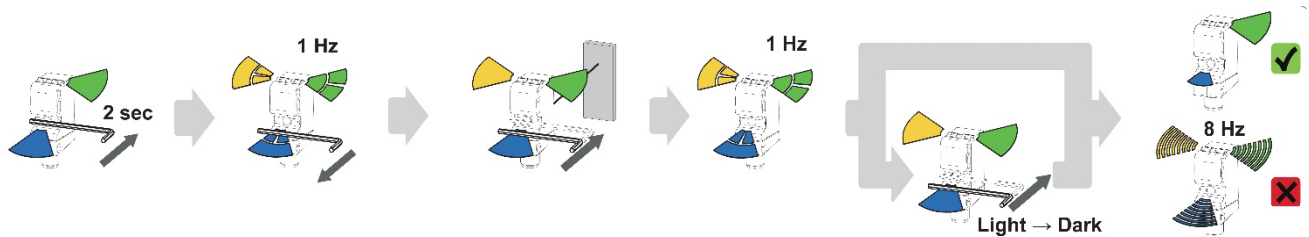

Teach-in procedure for 2-point teach (for objects close to the background):

1. Adjust the sensor to the object to be detected and make sure that the blue teach LED is on.
2. Touch the blue teach LED at the back of the housing with a ferromagnetic tool for **longer than 4 seconds, but shorter than 6 seconds**, until all 3 LEDs flash at **2Hz**. The blue LED is on more strongly as soon as a tool is detected.
3. Adjust the sensor to the object to be detected and quickly touch the blue teach LED with a ferromagnetic tool to confirm the position of the object.
4. Remove the object from the detection range and touch the blue teach LED quickly to teach the background.
5. As soon as the blue LED is on, the teaching process is completed.
6. If all 3 LEDs are blinking fast (8Hz), the teach process has failed and must be repeated.
7. If the sensor is to work as an opener, first teach in the background and then the object to be detected.

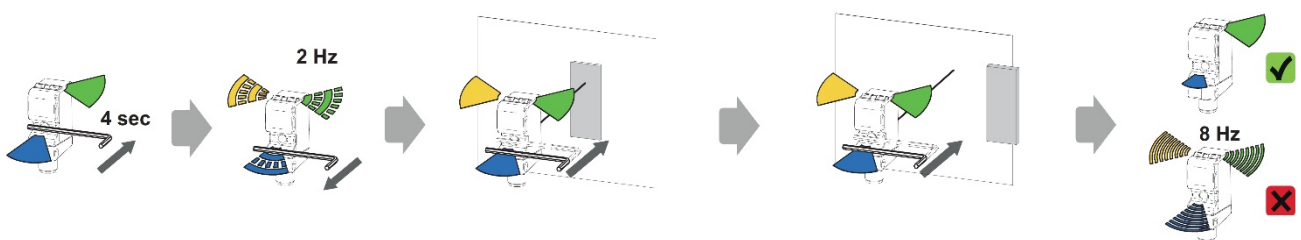

Reset to factory setting



Beam properties (typical values)

Light source	Laser diode	InGaAlP
Wavelength		656nm
Beam shape	Focused into a point	Elliptisch
Fokus Distanz		d_f 80mm
Beam size	At exit aperture	d_v / d_h 1.5mm / 2.5mm
	At focal point	d_v / d_h < 0.07mm / < 0.07mm
Beam divergenz		δ_v / δ_h 1.0° / 1.8°
Puls duration	Variabel	< 1.3µs
Puls period	Variabel	> 30µs
Duty cycle	Variabel	< 4.4%
Pulse power	Constant	< 3.0mW

Laser classification

Laser class (IEC 60825-1, 2014)	1
Maximum pulse power	< 3.0mW
Safety distance (*)	NA [m]

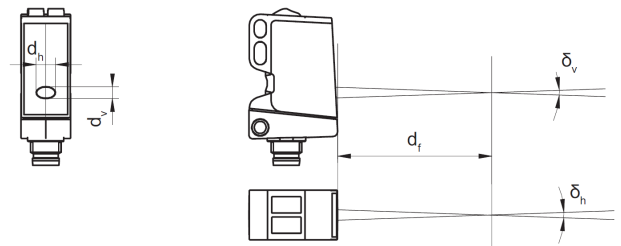

(*) Outside the safety distance, the achievable hazard is below the laser class 1 limitation.

Caution: Deviations from the procedures and settings specified here may result in dangerous radiation effects.

CLASS 1 LASER PRODUCT

IEC 60825-1/2014
Complies with 21 CFR 1040.10 and 1040.11
except for deviations pursuant to laser notice No. 50, dated June 24, 2007

CAUTION

Do not point the laser beam towards someone's eye. It is recommended to stop the beam by a mat object or mat metal sheet

SAFETY NOTES

Before commissioning, please ensure that all safety instructions in the product documentation, if applicable, have been observed!

If there is a direct impact on personal safety, the use of these products is prohibited.