

SL430020

Programmable airflow sensor 0.04...15 Nm³/h with IO-Link

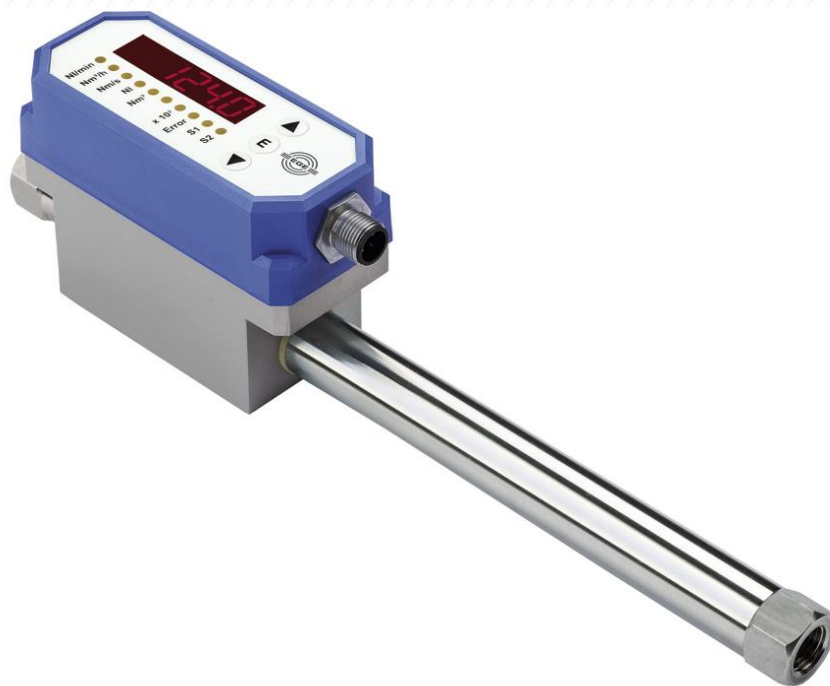

Use  **IO-Link**
Universal · Smart · Easy

1	Preliminary remarks	5
1.1	Target group	5
1.2	Used symbols	5
2	Safety instructions	6
3	Intended use	6
4	Measuring principle of the mass flow sensor	6
5	Application area	7
5.1	Limit value monitoring with switching output	7
5.2	Measurement with analog output.....	9
5.3	Air consumption meter	10
5.4	Dosing/Filling function.....	11
5.5	Fault detection with switching output	13
6	Special functions	13
6.1	User profile	13
6.2	Manipulation monitoring.....	14
7	Installation	15
7.1	Dimensions.....	15
7.2	Mounting in a pipeline.....	16
7.3	Air quality requirements	16
7.4	Inlet and outlet path	17
8	Electrical connection diagram	18
9	Operating and display elements	19
9.1	Display.....	19
9.2	Unit and status LEDs	19
9.3	Buttons	20
10	Display and operating mode	21
10.1	Power-up procedure	21
10.2	Quick view of parameter values.....	22
11	Programming	23
11.1	Start of programming	23
11.2	Structure of main menu	24
11.3	Extended functions	28

12 IO-Link.....	39
12.1 General.....	39
12.2 IODD.....	39
12.3 Device data.....	40
12.4 Process data.....	40
12.5 Standard commands.....	41
12.6 On-request data.....	42
12.7 Events.....	49
12.8 Error messages.....	49
13 Designations (alphabetical order).....	50
14 Technical data.....	56
14.1 Electrical data.....	56
14.2 Detection of flow rate.....	56
14.3 Air consumption metering.....	57
14.4 Temperature monitoring.....	58
14.5 Response times.....	58
14.6 IO-Link-Device.....	59
14.7 Mechanical data.....	59







Figure 1: Hysteresis operation mode	8
Figure 2: Operating mode window monitoring.....	9
Figure 3: Operating mode: pulsating output.....	10
Figure 4: Operating mode analog output.....	11
Figure 5: Start der Dosierfunktion mit positiver Flanke	12
Figure 6: Start of filling function with a negative edge.....	13
Figure 7: Dimensions of SL430020.....	16
Figure 8: Mounting plate (optional)	16
Figure 9: Rated inlet path.....	18
Figure 10: Front view SL430020.....	20
Figure 11: Power-up procedure	22
Figure 12: Quick view of parameters	23
Figure 13: Start of programming	25
Figure 14: Structure of main menu.....	26
Figure 15: Input of dosing/filling amount	27
Figure 16: Entering of super code.....	29
Figure 17: Structure of menu "Extended functions".....	30
Figure 18: Data analysis	31
Figure 19: Configuration of the outputs.....	32
Figure 20: Configuration of the display	33
Figure 21: Structure of locking menu	35
Figure 22: Reference temperature and reference pressure	36
Figure 23: Displayable characters.....	37
Figure 24: Reset to factory settings	38

1 Preliminary remarks

1.1 Target group

These operating instructions contain information and provisions for experts who are familiar with working on pneumatic and electrical installations.

1.2 Used symbols

	<p>Additional information or notes, which are helpful for special application.</p>
	<p>Warning</p>
	<p>Numeric string, shown in the display of the device.</p>
	<p>Device button</p>
	<p>Device button</p>
	<p>Device button</p>
	<p>Apply power supply to sensor.</p>

2 Safety instructions



The sensor must only be installed by trained specialist personnel. Protect the sensor securely against mechanical damage. The relevant compressed air networks must be switched to a depressurized state. When working on electrical equipment the applicable rules must be observed. After use, the sensor must be disposed professionally, it doesn't belong to the domestic waste.

3 Intended use

The sensor **SL430020** measures the airflow velocity and the air temperature inside of the integrated measuring pipe. Flow rate and air consumption can be calculated from the flow velocity related to a standard condition. The air consumption is stored in the device every 15 minutes. The air flowing through the sensor must meet the quality requirements of class 1.4.1 (ISO 8573-1). The area of application of the sensor are industrial compressed air networks with a maximum pressure of 16 bar.

4 Measuring principle of the mass flow sensor

The measuring principle of the sensor is calorimetric. A heated temperature measuring element is cooled by the passing medium. Another measuring element records the medium temperature. The temperature difference between the two measuring elements is a measure for the flow rate and is analysed electronically and digitally. The values shown in the display refer to a standard condition. The factory settings are: 1013 mbar and 15 °C.

i	→ 11.3.11 Entering of reference temperature and reference pressure p. 35
----------	--

5 Application area

5.1 Limit value monitoring with switching output

These measurands can be monitored:

- Flow velocity [Nm/s]
- Flow rate [NI/min], [Nm³/h]
- Consumption [NI], [Nm³]
- Temperature [°C]

5.1.1 Hysteresis operation mode (Limit value monitoring)

The outputs **S1** and **S2** can be managed independently of each other in the hysteresis operation modes **Hno** (normally open) and **Hnc** (normally closed). The configuration as PNP or NPN output can only be done for both outputs in common.

The flow rate or temperature are monitored with the limit values in **SP1** and **SP2**. If the values fall below the limit or exceeds the limit the output status changes. The difference between the switch-on and the switch-off value is called hysteresis. It can be determined in the parameters **HYS1** and **HYS2**. In addition a switch-on delay **dS1** and **dS2** and a switch-off delay **dr1** and **dr2** can be programmed. In the menu section „Extended functions“ the parameter **Uni.SP1** and **Uni.SP2** can be set to temperature °C or flow **Flo**.

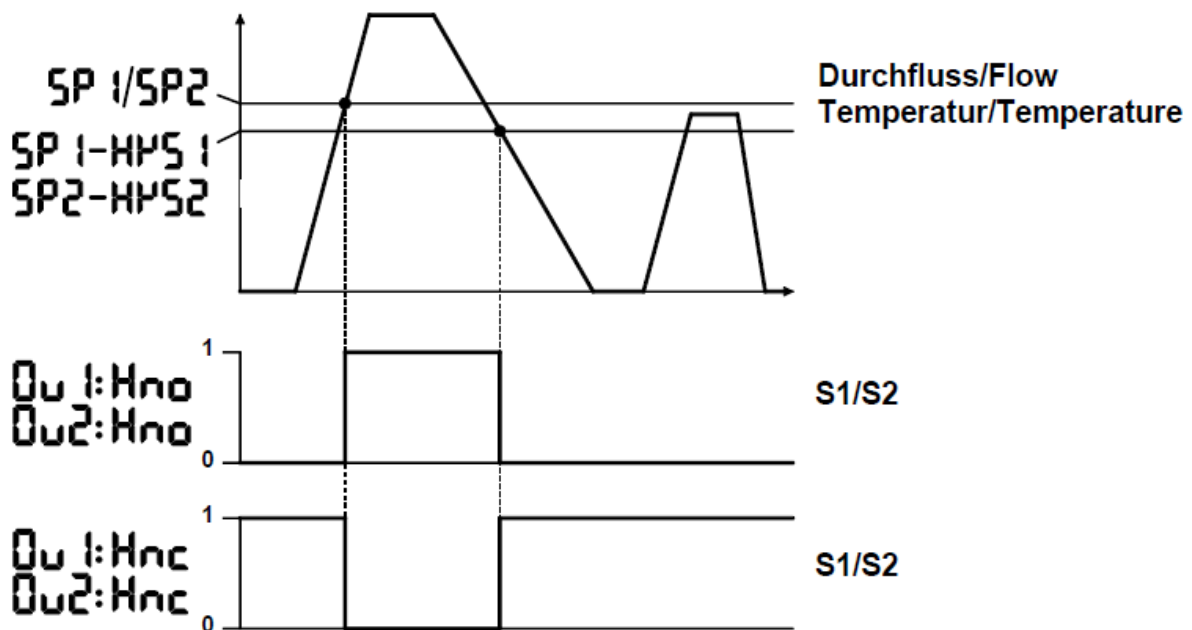

Figure 1: Hysteresis operation mode

5.1.2 Operation mode window monitoring

The outputs S1 and S2 can be managed independently of each other in the window operation modes **Fno** (normally open) and **Fnc** (normally close). The configuration as PNP or NPN output can only be done for both outputs in common.

The to be monitored window is defined by the lower limit values **FL1 / FL2** and the upper limit values **FH1 / FH2**.

If the measured flow rate or temperature is inside the defined window, the corresponding output is activated or deactivated. In addition a switch-on delay **ds1** and **ds2** and a switch-off delay **dr1** and **dr2** can be programmed. In the menu section „Extended functions“ the parameter **Uni.SP1** and **Uni.SP2** can be set to temperature °C or flow **Flo**.

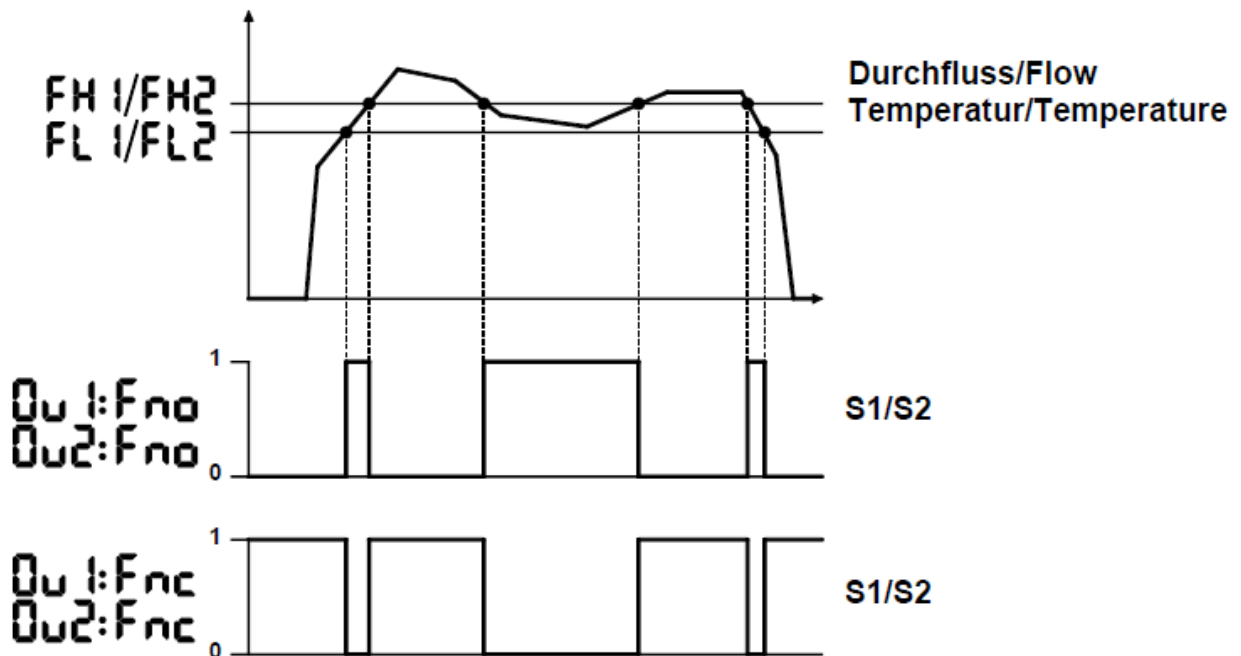

Figure 2: Operating mode window monitoring

5.2 Measurement with analog output

- 5.2.1 Operating mode: pulsating output..... Fehler! Textmarke nicht definiert.
- 5.2.2 4...20 mA analog output..... Fehler! Textmarke nicht definiert.

These measurands can be measured analog:

- **Flow velocity [Nm/s]**
- **Flow rate [NI/min], [Nm³/h]**
- **Temperature [°C]**

For the output of an analog value the pulsating output or the 4 to 20 mA output can be used.

5.2.1 Operating mode: pulsating output

The output **S1** can be set up as pulse output for the flow rate in the programming menu by selecting **PuLS** for the **OU1** parameter. The **PS** parameter contains the value for the pulse valence in **[NI]**. This is the volume flowing through the sensor before a pulse is issued.

The pulse length changes with the valence selected. The **S1** output operates as normally open.

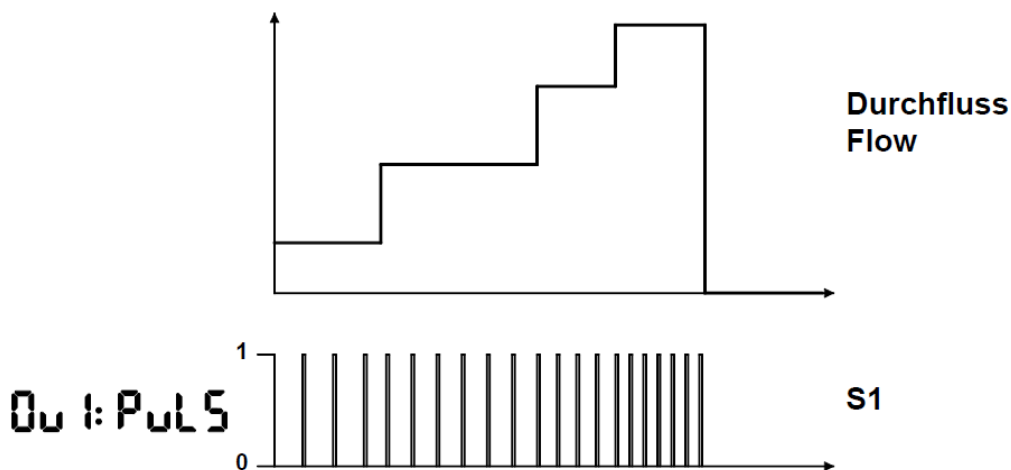

Figure 3: Operating mode pulsating output

5.2.2 4...20 mA analog output

By selection of the parameter value **I** the output **S2** can be set to 4...20 mA output. The selection of temperature °C or Flo for the parameter **Uni.AOu** can be done in the menu section „Extended functions“.

The parameter **A.Str** and **A.End** contain the reference values for the output of 4 mA and 20 mA. They are queried in the main menu.

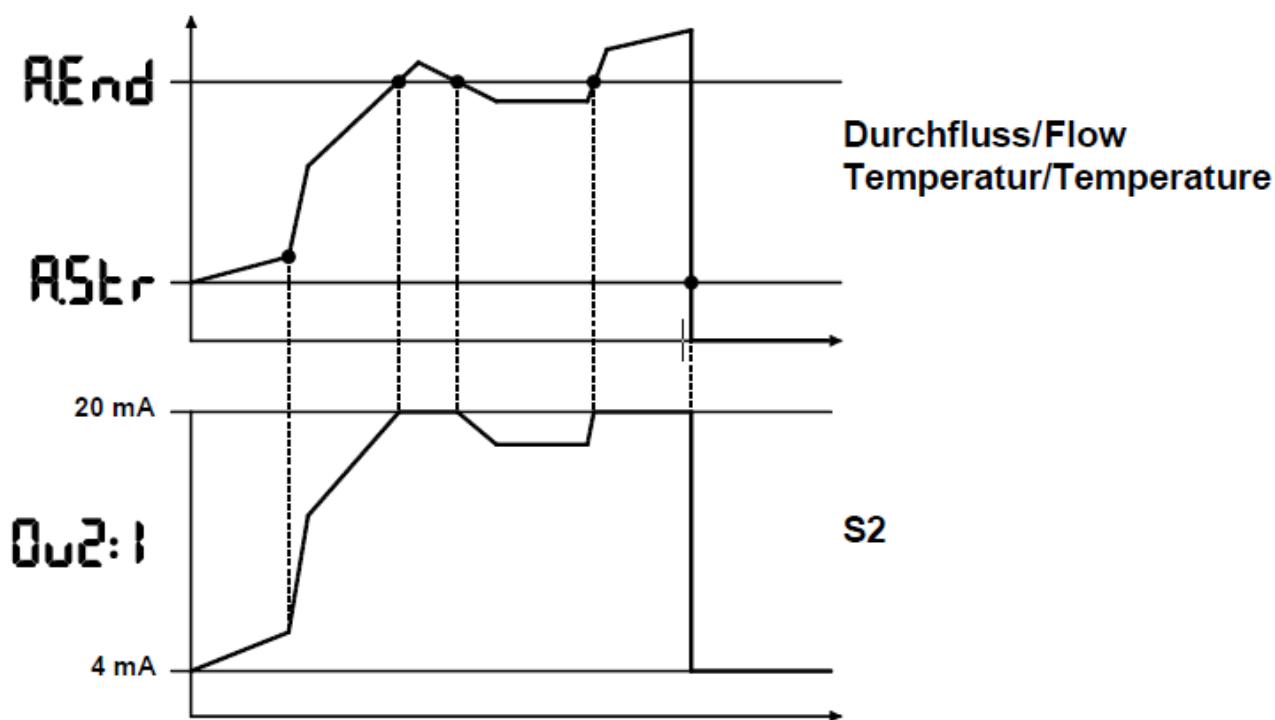

Figure 4: operating mode analog output

5.3 Air consumption meter

The air consumption is calculated from the mass flow signal of the sensor. This value is processed by the unit and filed as a volume value in the parameter **TOTAL** and stored every 15 minutes.

It is possible to display the value or to reset the value to zero manually in the menu section „Extended functions“. For continuously showing the consumption the display of the device can be configured with the parameter **CFG.diS**.

5.4 Dosing / Filling function

5.4.1 Process starts with a positive edge11
 5.4.2 Process starts with a negative edge12
 5.4.3 Process starts with a button..... Fehler! Textmarke nicht definiert.

The dosing/filling function provides an output signal at the S1 output once the volume entered in doSSP has been reached. The counter and the S1 output are reset via the keypad or by applying a voltage signal to the S2 output. To this end the value rin must be selected for the Ou2 parameter.

5.4.1 Process starts with a positive edge

The internal counter can be started with a positive edge. This is done by briefly applying a voltage to the S2 output or with the rising edge of a pulse. The sensor sets the internal counter to 0 and starts it. At the same time the S1 output is reset.

Once the internal counter has reached the parameter value in doSSP, the S1 output is set again.

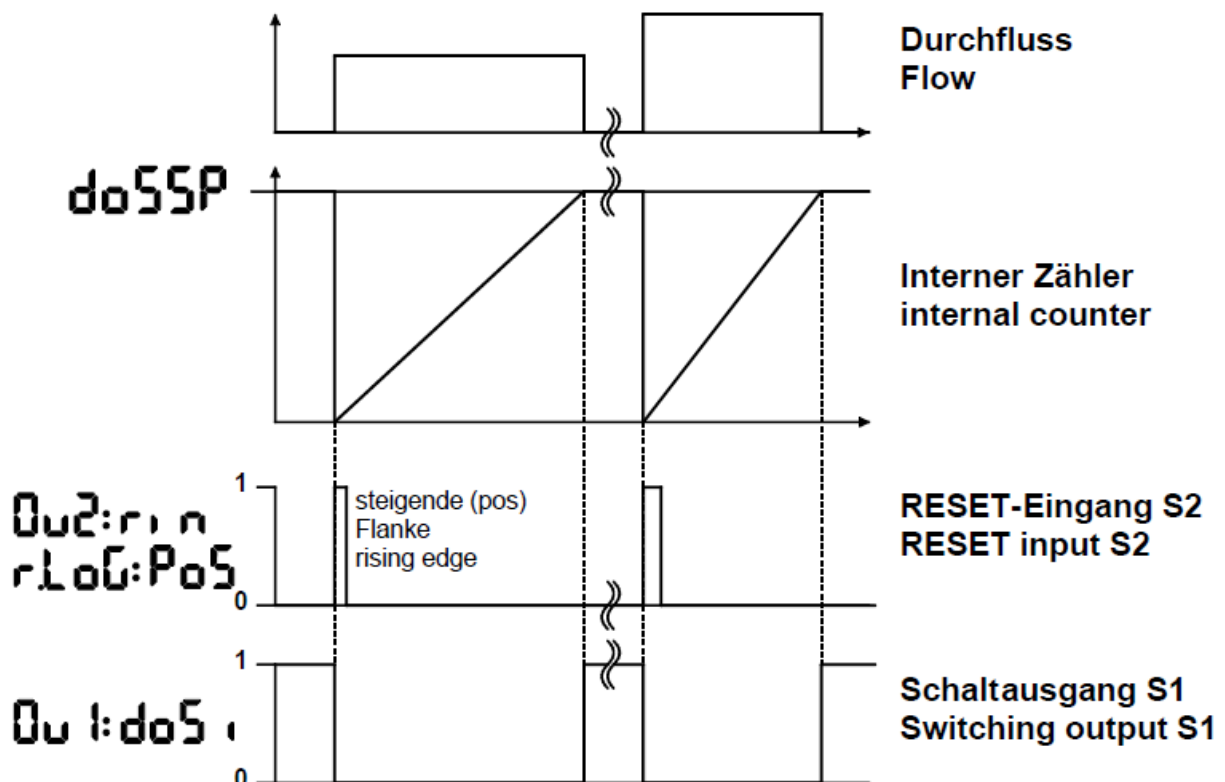

Figure 5: Start of dosing function with positive edge

5.4.2 Process starts with a negative edge

The internal counter can be started with a negative edge. This is done by briefly interrupting a voltage to the **S2** output or with the falling edge of a pulse. The sensor sets the internal counter to 0 and starts it.

The **S1** output is reset.

Once the internal counter has reached the parameter value in **doSSP**, the **S1** output is set again.

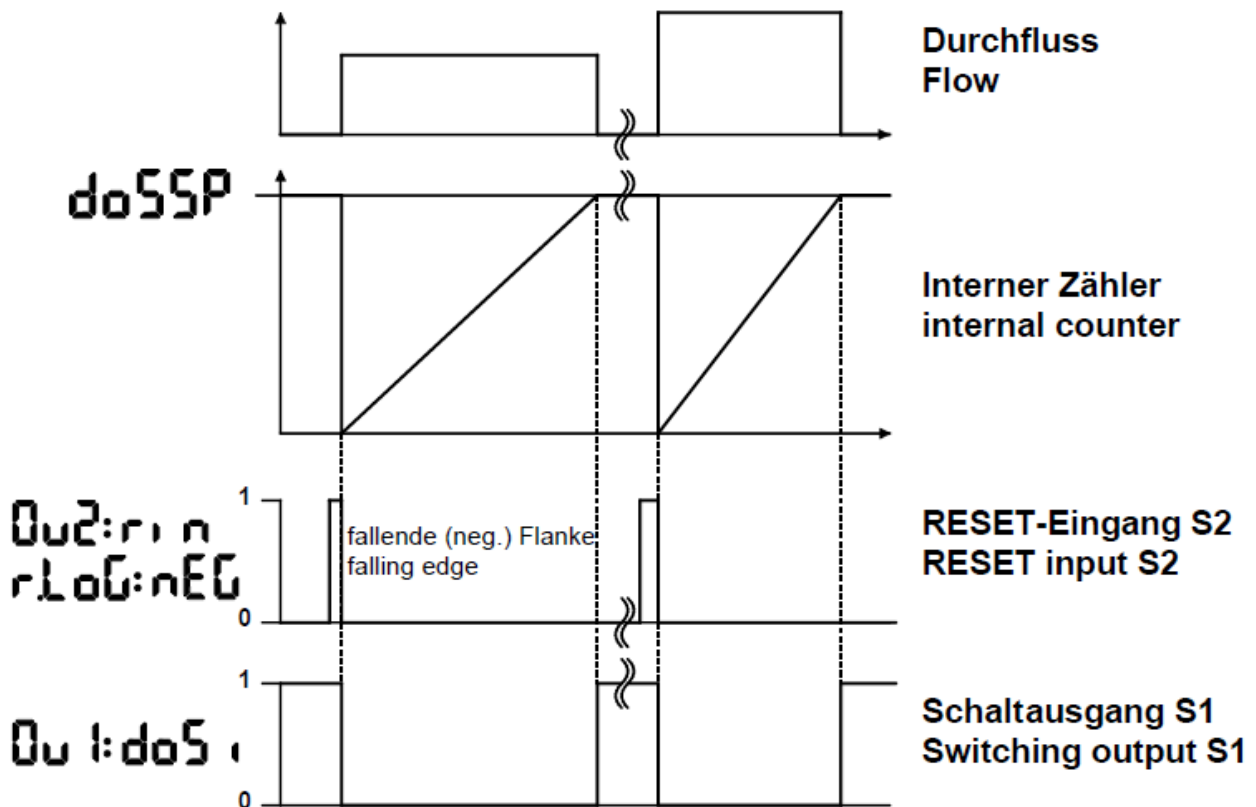

Figure 6: Start of filling function with a negative edge

5.4.3 Process starts with a button

In the main menu the value **doS** is selected for the **Ou1** parameter and the desired value entered in the **doSSP** parameter. Resetting and starting the counter or the metering/filling process takes place after selecting the function **rES** for the **dPr** parameter. With **rES** the process can be cancelled and a new one started.

5.5 Fault detection with switching output

The output **S2** can be assigned the operating mode fault monitoring by selecting the parameter values **Eno** and **Enc**. If the device diagnosis detects a fault, the **S2** output is set (**Eno** / closer) or reset (**Enc** / opener). The **Err.C** parameter is described with a failure code providing information about the type of fault. This can be accessed in the main menu.

i	Failure codes and description	
	1	Hardware failure
	2	UB < 18V
	3	UB > 30V
	4	Medium temperature < 0°C
	5	Medium temperature > 60°C
	6	Operating temperature inside of device is too high
	7	Short at one of the outputs

6 Special functions

6.1 User profile

The sensor provides the option to restrict the scope of operation of a user group to the modification of certain parameters.

The sensor “administrator” sets up a “super code” giving him access to the extended functions.

Parameters can be selectively blocked there.

i	For example the plant manufacturer can release only one output for the user group “Plant operators” and operate the second output with a non-changeable operating mode.
	→ Locking menu functions p. 33

6.2 Manipulation monitoring

The sensor features a modification counter which is incremented with every parameterisation regardless of whether this takes place via the buttons or the IO-Link interface. Thus every modification of the device configuration can be detected. The counter is visible to user groups with access to the “Extended functions”. The counter cannot be reset.



→ Read out of modification counter p. 37

7 Installation



To achieve the specified accuracy, the installation requirements and the requirements for the air quality must be complied with. Prior to opening ensure that the line has been depressurised. Observe the applicable regulations.

The yellow protective screws should only be removed just prior to assembly to prevent damaging the measuring system.

7.1 Dimensions

(± 1.5 mm)

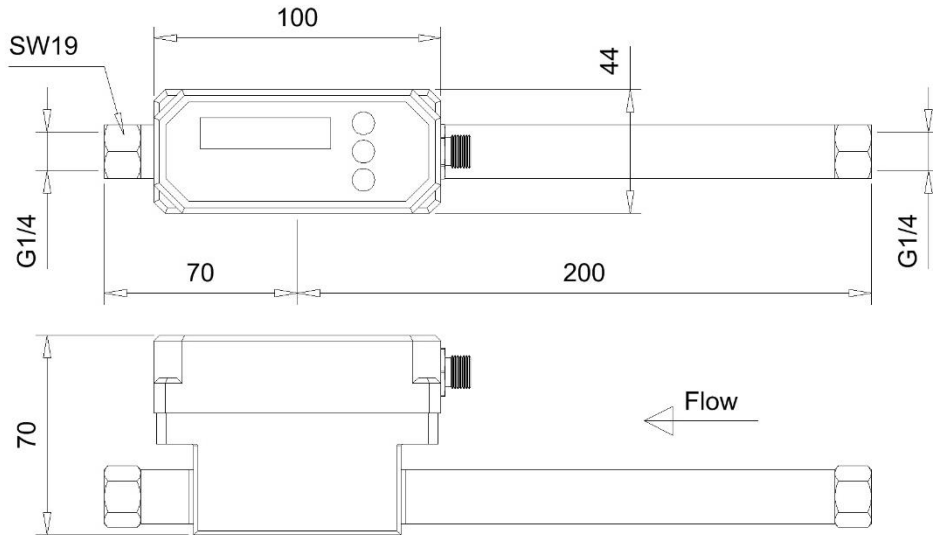

Figure 7: Dimensions of SL430020

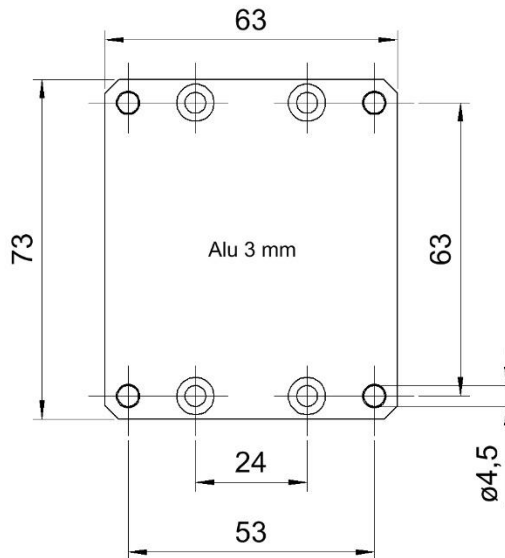

Figure 8: Mounting plate AS000011 (optional)

7.2 Mounting in a pipeline

The flow profile developing near the measuring elements must match the profile during factory calibration. For coupling to a straight pipeline with an internal diameter of $\varnothing 9 \text{ mm}$ the measuring path fitted to the device is sufficient. If the sensor is installed in a horizontal line, assembly with the display pointing up perpendicular is preferred. The length of the inlet path from the housing outlet must be designed in accordance with the figures below in case of faults.

7.3 Air quality requirements

The quality of compressed air is described in ISO 8573-1 and divided into classes in accordance with the degree of contamination. For the operation of the air flow sensor compressed air of classification 1.4.1 has been specified.

The first digit indicates the number and size of the permissible solids particles per m^3 air. The following applies to the classification in class 1:

0.1...0.5 μm	$\leq 20,000$
0.5...1 μm	≤ 400
1...5 μm	≤ 10

The second digit defines the requirement for the water content, the moisture in the compressed air. Class 4 requires a pressure dew point of $\leq 3^\circ\text{C}$. No condensation is permitted.

The third digit specifies the permissible oil content of the air. For the operation of the sensor this must not exceed 0.01 mg per cubic metre.



Contamination in the compressed air leads to deposits and adhesions at the sensor which might cause measuring errors.

7.4 Inlet and outlet path

	Flow disturbance in	Length of inlet path	Length of outlet path
	Simple 90°-elbow	400 mm	No additional path length required
	≥ 2 elbows 90° in one layer		
	Valve		
	Expansion of diameter		
	≥ 2 elbows 90° in different orientation	680 mm	
	Reduction of diameter	250 mm	

Figure 9: Rated inlet path

8 Electrical connection diagram

The selection of the operating mode for the output **S1** and the output **S2** occurs in the main menu.

S1 and S2 as switching output PNP-NO/NC

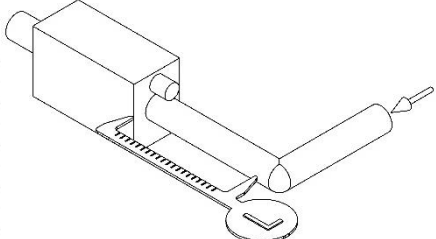
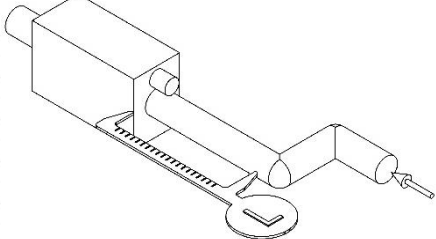
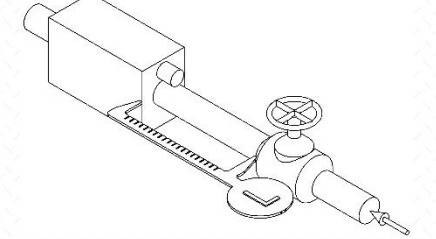
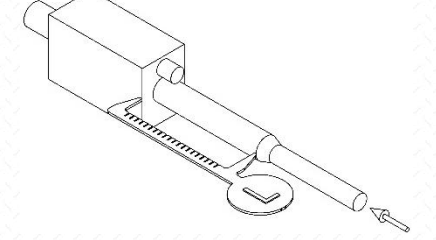
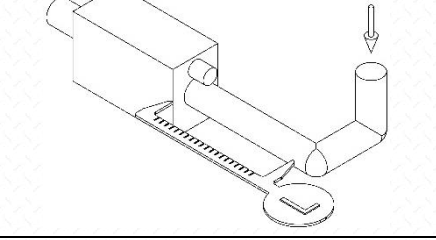
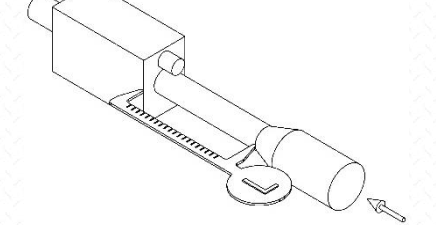
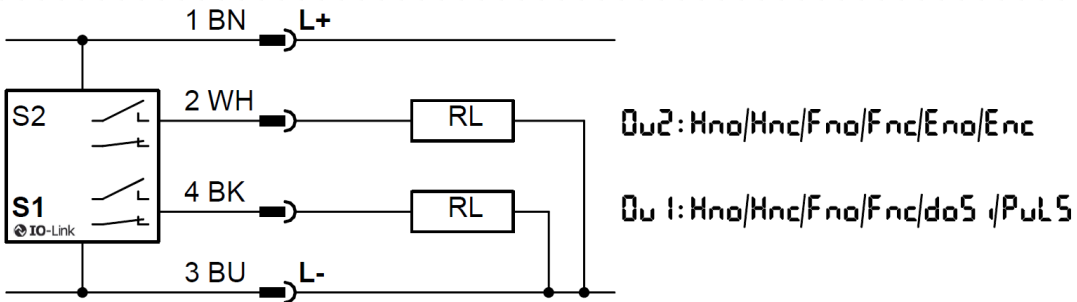

S1 and S2 as switching output NPN-NO/NC

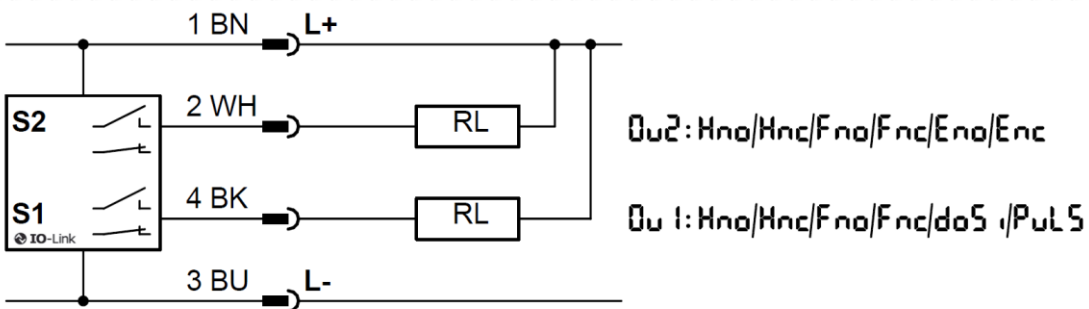

S1 as switching output and S2 as analog output 4...20 mA

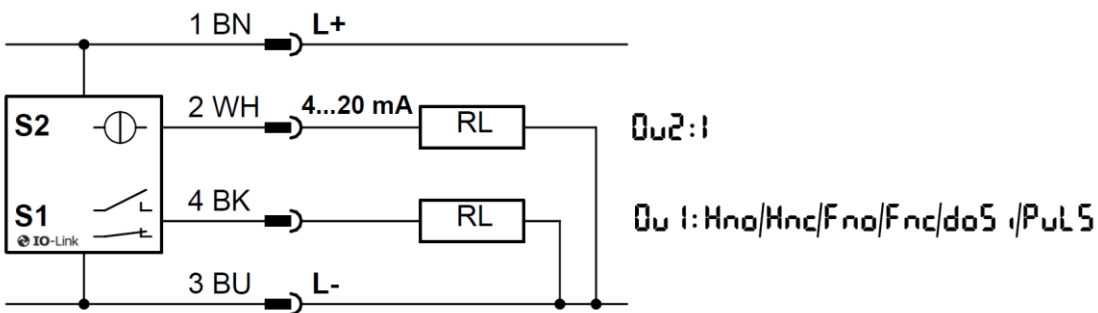

S1 as switching output and S2 as reset signal input for dosage

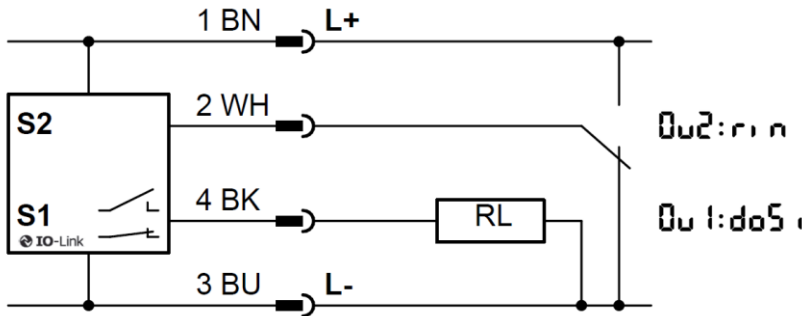

9 Operating and display elements

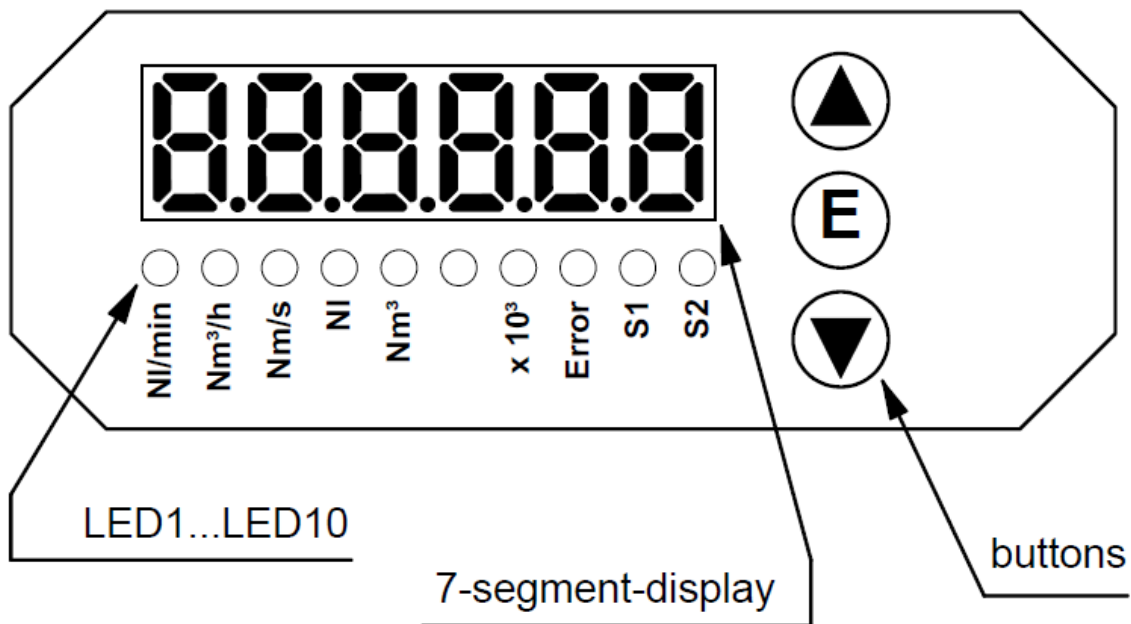

Figure 10: Front view SL430020

9.1 Display

In the six digit display the process parameters and values are displayed using alphanumeric characters and number sequences. The operating modes of the display during the display and operating mode can be selected in the menu “Extended functions”.

9.2 Unit and status LEDs

10 individual LEDs provide additional information to present the process values.

LED1 and **LED2** indicate the units of the displayed value for the current flow rate.





LED3 illuminates if the measured flow rate is displayed in the display.

LED4 or **LED5** illuminates if the consumption value is displayed. **LED6** is not used in this sensor. In addition to the unit **LEDs**, **LED7** might illuminate. The displayed value must then be multiplied by 1000.

LED8 illuminates if the internal diagnosis has detected a fault state.

LED9 and **LED10** indicate the state of the outputs S1 and S2. They illuminate if the outputs **S1** and/or **S2** have been switched.

9.3 Buttons

	Change to the next parameter Increase of parameter value Change between given parameter values
	Confirmation of the selection of a parameter or a parameter value Switch between digits during entering of code number Switch between parameters in the quick view Immediate storage of consumption value
	Change to the next parameter Decrease of parameter value Change between given parameter values
 & for min. 3 seconds	Start of programming mode

10 Display and operating mode

10.1 Power-up procedure

After applying the operating voltage the sensor runs through the power-up procedure. The parameters contain the already configured values or factory settings. The device performs a self-test and is then in the display and operating mode.

During the power-up procedure all segments, the decimal points and the individual LEDs of the display are activated for approx. 0.5 seconds in a first step. Next the software revision is briefly displayed. Then the application tag appears. This is a customer-specific combination of characters which can be configured in the programming menu.

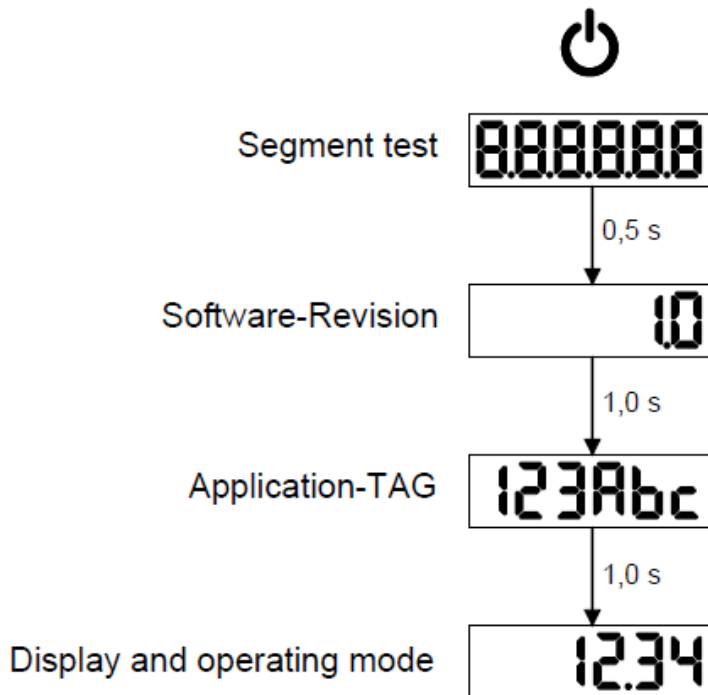

Figure 11: Power-up procedure

In the display the current measured value is displayed together with the corresponding LED for the unit. Dependent on the configuration the temperature can be displayed alternating with the flow rate. The temperature value is displayed together with the unit °C in the 7 segment display.

10.2 Quick view of parameter values

The parameters and corresponding values can be displayed in the display and operating mode without entering the programming mode. By repeatedly pressing the **E** button the parameters relevant for the configuration are successively accessed. If the **E** button is not actuated for two seconds, the value belonging to the parameter appears in the display.

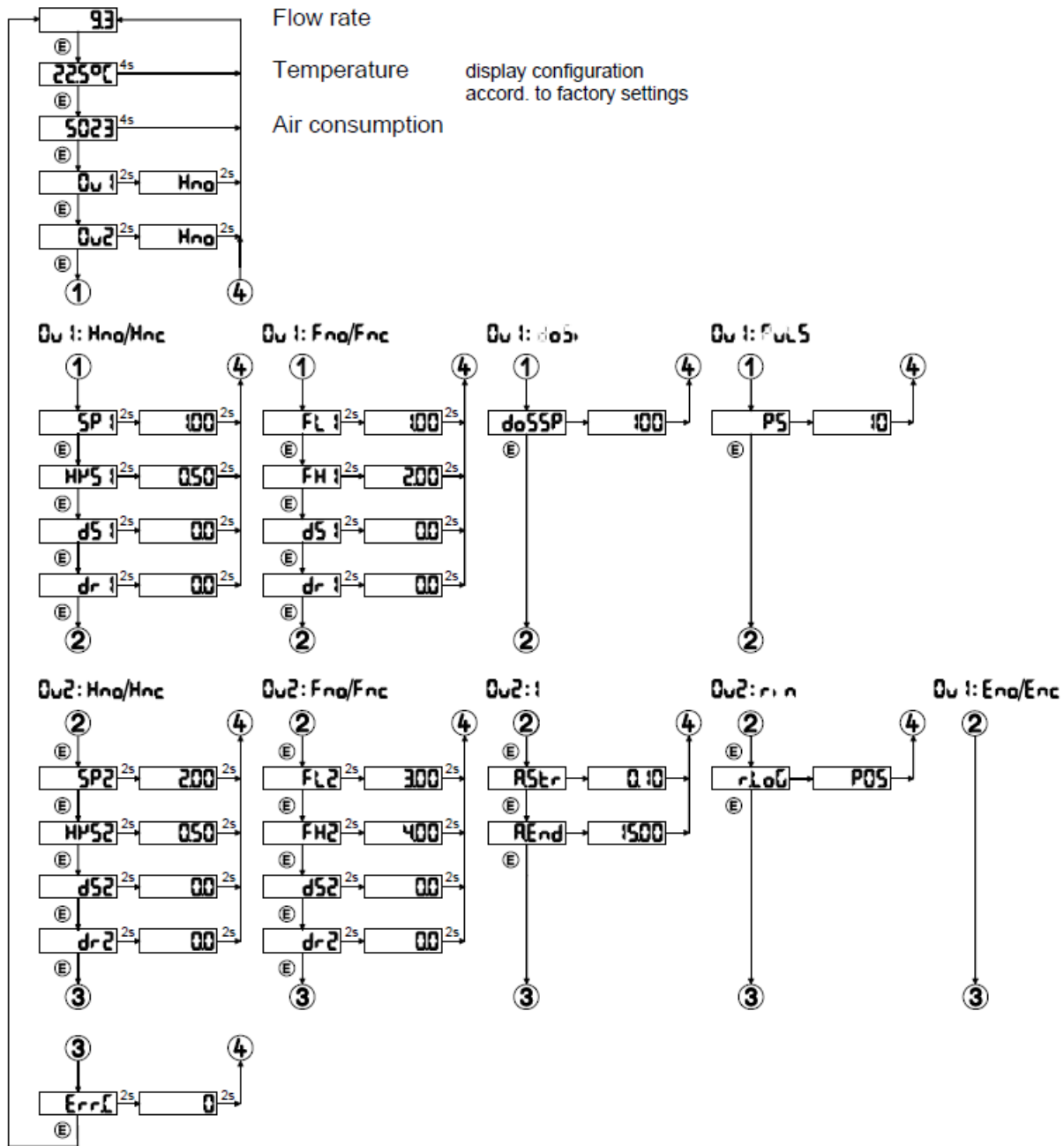



Figure 12: Quick view of parameters



11 Programming

The flow rate sensor is programmed via button inputs or via the standardised IO-Link interface.

Programming using this interface has been described in a later chapter. The programming mode must be exited before shutting down the device.

11.1 Start of programming

The programming mode is entered by simultaneously pressing the  and  buttons for min. 3 seconds until the **CodE** string appears in the display. If no further buttons are pressed, a prompt to enter the four digit access code appears shortly after.

Using the  and  buttons the respective flashing digit can be changed.  confirms the entry and changes to the next digit. After entering the fourth digit the verification takes place and if the access code is correct the main menu is opened. After an incorrect entry **Err** is displayed for 1 second with a return to the display and operating mode.

	<p>If the IO-Link mode is activated and a data transfer takes place, programming at the device is not possible. If programming is attempted, the message LoC appears in the display.</p>
	<p>Using an IO-Link function, parameterisation at the device can be blocked. If programming is attempted, LoC appears in the display. Manual parameterisation can only be released again via the IO-Link function.</p>

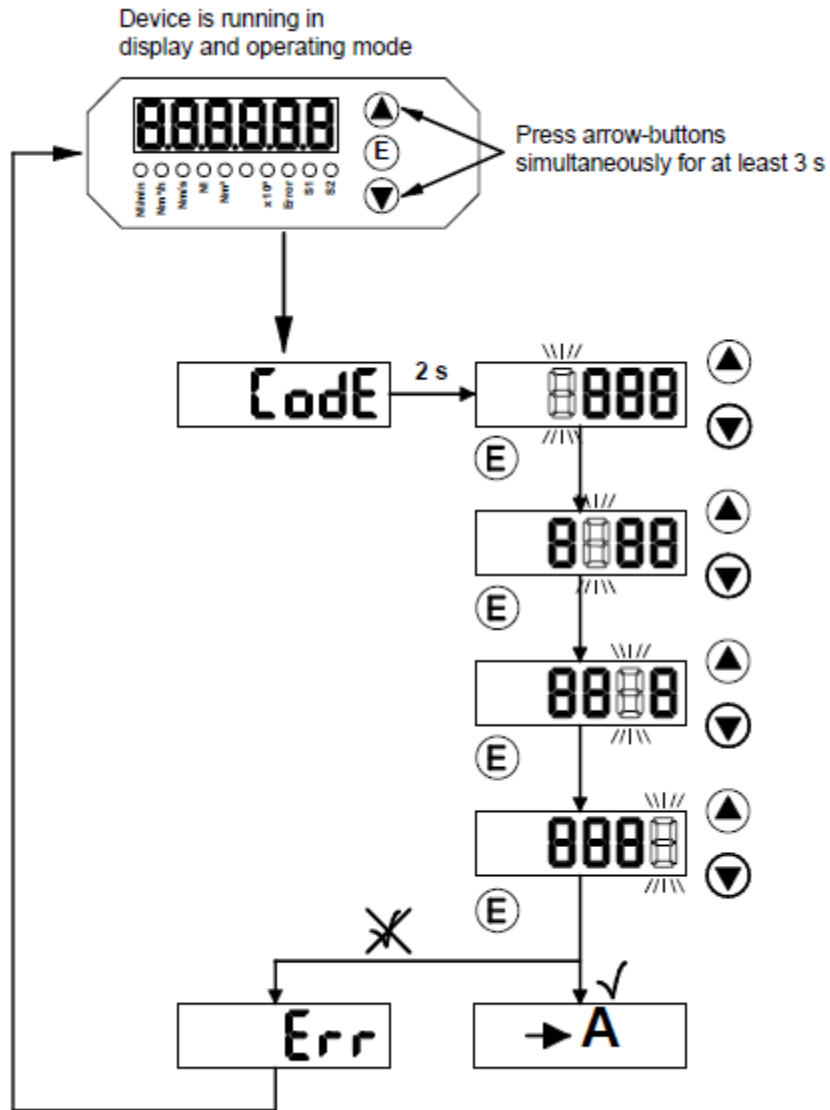
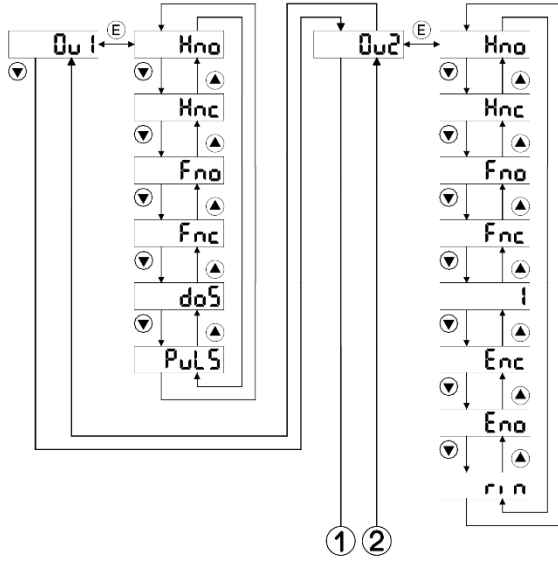

Figure 13: Start of programming

i	A → Figure 14: Structure of main menu p. 26
----------	---

11.2 Structure of main menu

The main menu follows after entering the access code correctly. Here the operating modes are first assigned to the outputs **S1** and **S2**. Dependent on the operating mode, the values for the relevant parameters are queried.



Qu 1: Hno/Hnc

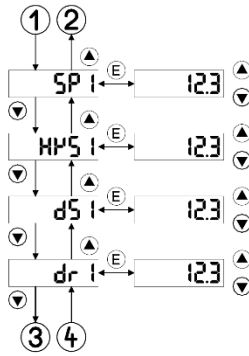

Qu 1: Fno/Fnc

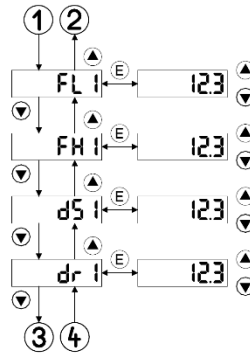

Qu 1: doS

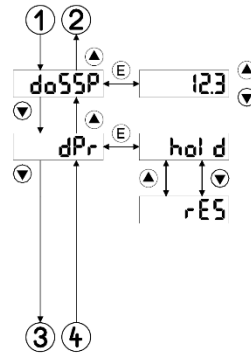

Qu 1: PuLS

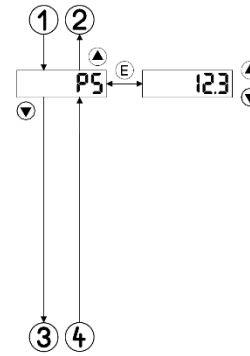

Qu 2: Hno/Hnc

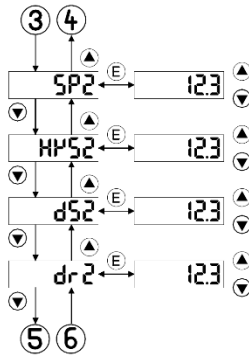

Qu 2: Fno/Fnc

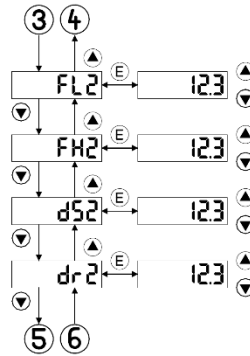

Qu 2: |

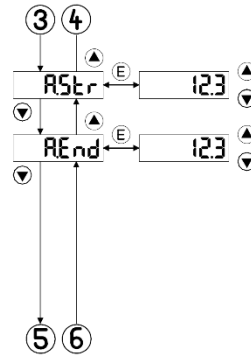

Qu 2: r:n

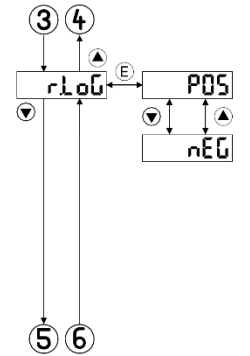

Qu 2: Eno/Enc

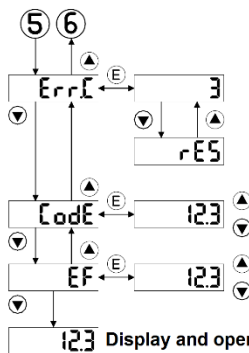
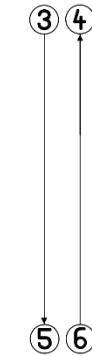

Figure 14: Structure of main menu

11.2.1 Input of dosing/filling amount

The **doSSP** parameter is queried in the main menu if the value **doSi** was selected for the **Ou1** parameter.

When selecting the value range, the unit and factor LEDs must be noted.

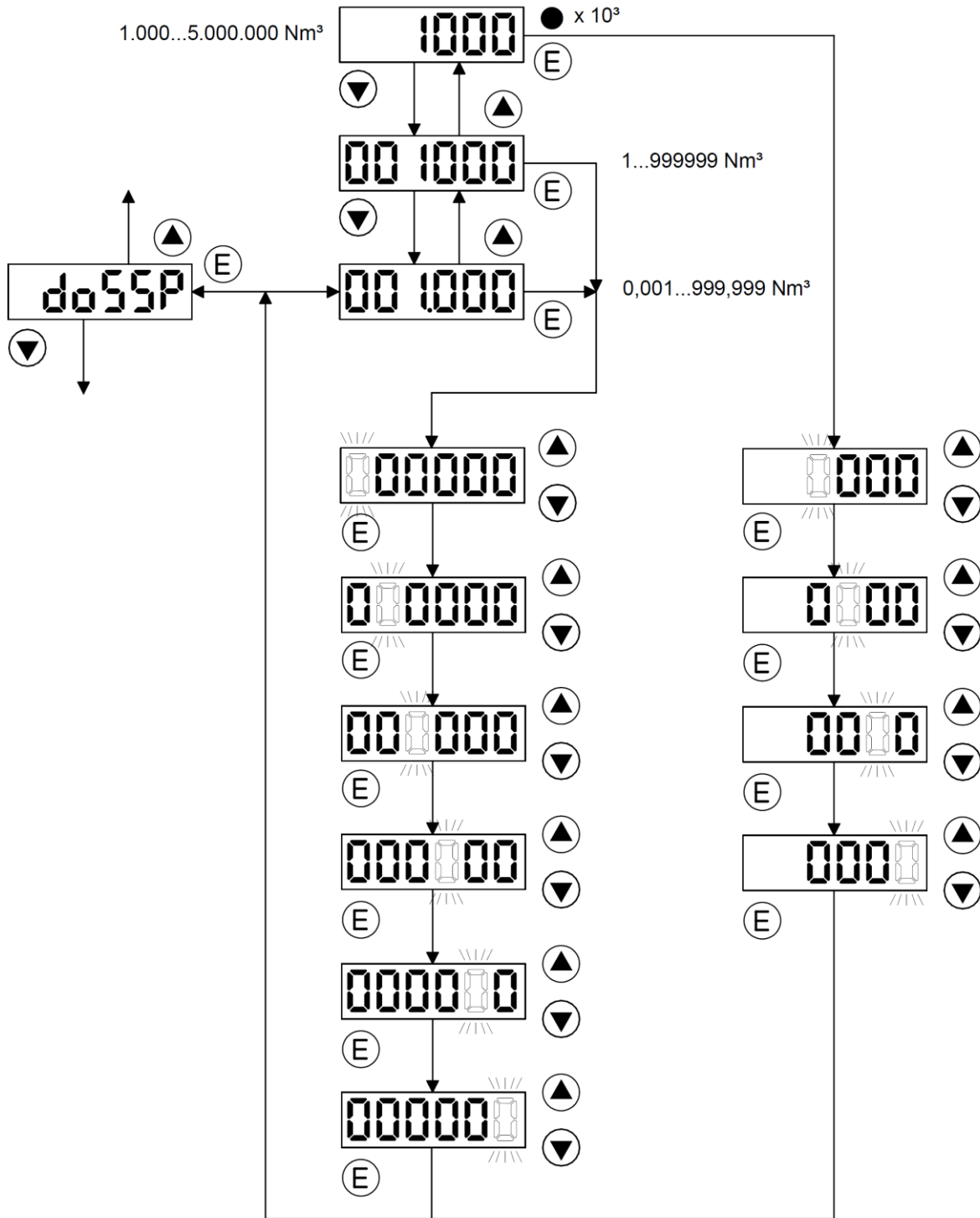

Figure 14: Input of dosing/filling amount

11.2.2 Read out/reset of failure code

The failure code is found in the **Err.C** parameter and can be queried in the main menu or in the quick view. Resetting is only possible in the programming mode in the main menu. To do so, the **rES** function is selected for the corresponding parameter.

11.2.3 Set up/modification of access code

To restrict access to the programming menu, an access code can be set up. This access code must differ from the factory setting of **0000**. To set up/modify it, the **Code** parameter is selected and a corresponding 4 digit number combination entered.

11.3 Extended functions

- 11.3.1 Entering of super code for „Extended functions“ menu 28
- 11.3.2 Structure of menu „Extended functions“ 29
- 11.3.3 Entering of filter value..... 30
- 11.3.4 Data analysis..... 30
- 11.3.5 Configuration of the outputs.....31 **Fehler! Textmarke nicht definiert.**
- 11.3.6 Entering the creep feed rate 31
- 11.3.7 Reset of air consumption counter 32
- 11.3.8 Configuration of the display 32
- 11.3.9 Entering the unit for flow measurement 33
- 11.3.10 Locking menu functions..... 33
- 11.3.11 Entering of reference temperature and reference pressure 35
- 11.3.12 Entering of customized TAG number 36
- 11.3.13 Read out of modification counter **Fehler! Textmarke nicht definiert.**
- 11.3.14 Change of super code..... **Fehler! Textmarke nicht definiert.**
- 11.3.15 Reset to factory settings..... 37

The extended functions can be used after entering the super code **SCodE**. If no super code has been programmed, the release is issued after confirming the **0000** (factory setting) in the code query.

11.3.1 Entering of super code for „Extended functions“ menu

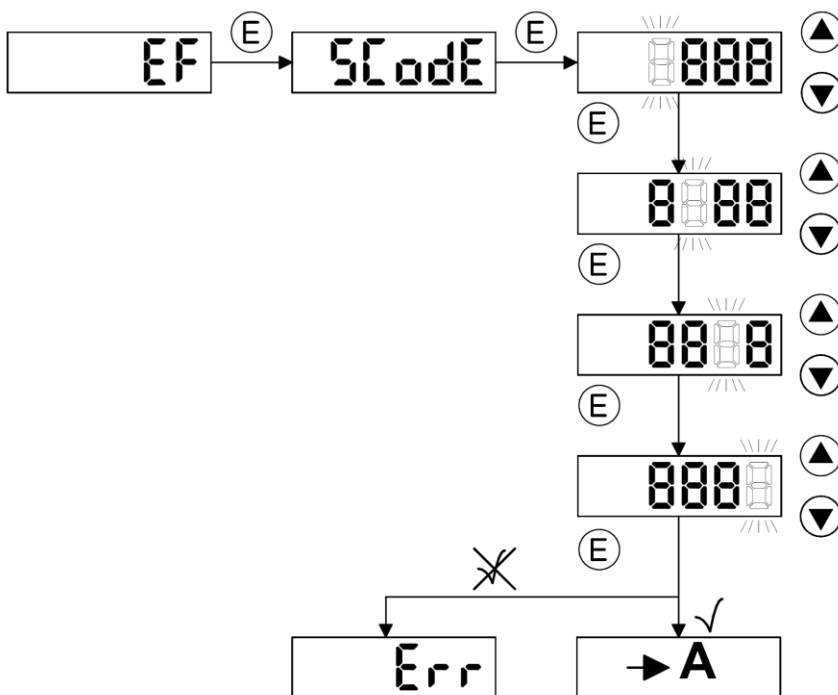
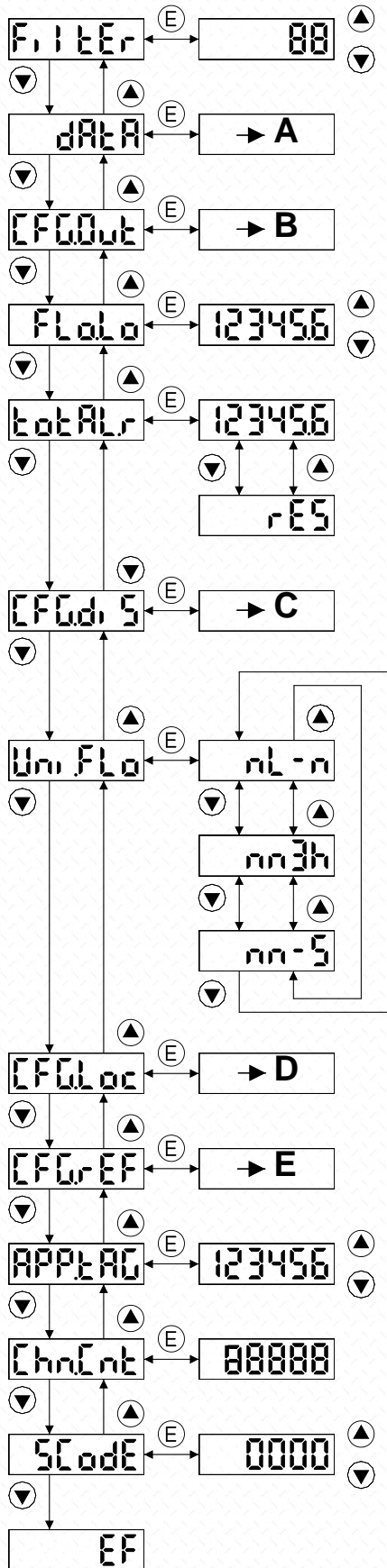

Figure 15: Entering of super code

i	A: → Figure 17: Structure of menu “Extended functions“ p. 30
----------	--

11.3.2 Structure of menu „Extended functions“



A: → 11.3.4 S. 30

B: → 11.3.5 S. 31

C: → 11.3.8 S. 322

D: → 11.3.10 S. 32

E: → 11.3.11 S. 35

Figure 16: Structure of menu “Extended functions”

11.3.3 Entering of filter value

The sensor features a function which generates the average value of the flow rate over a configurable time period. This average value is output continuously. The time period for the average value generation is entered in the menu “Extended functions” in the **FILtEr** parameter. 0, 1, 2, 4 and 8 seconds are available. For the most accurate consumption detection the value must be set to 0.

11.3.4 Data analysis

In the parameters **Lo.Flo**, **Hi.Flo**, **Lo.°C** and **Hi.°C** the lowest and highest measured value for the flow rate and temperature since the last reset are stored. An average of the measured values over a time period of the last 24 hours is also generated. The data are stored when the device is shut down.

All data can be reset via the keypad.

i	To determine the correct max. and min. values, the parameters should be reset manually after switching on the supply voltage.
----------	---

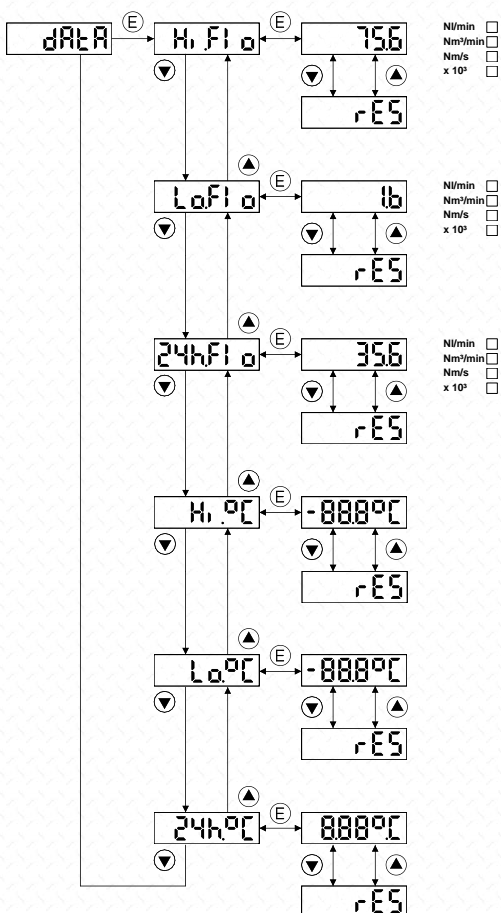

Figure 17: Data analysis

11.3.5 Configuration of the outputs

In the configuration menu **CFG.Out** the measuring variable for the outputs **S1** and **S2** is selected with the parameters **Uni.SP1**, **Uni.SP2** and **Uni.AOu**. The electrical switching behaviour of the outputs **S1** and **S2** is defined in the parameter **P-n**. PNP is defined with the **PnP** value and NPN with the **NPN** value.

Flow → Flo

Temperature → °C

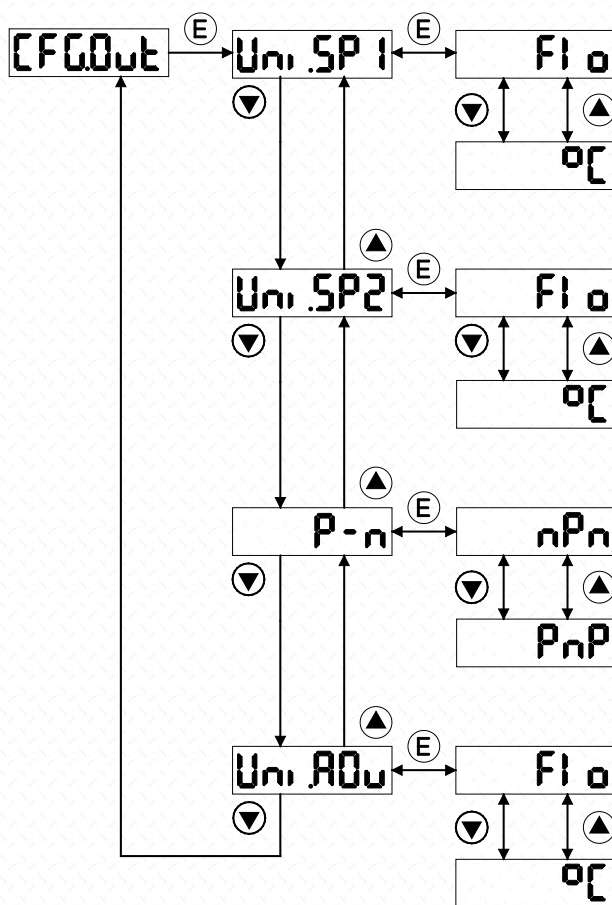

Figure 18: Configuration of the outputs

11.3.6 Entering of the creep feed rate

Measured values below the creep feed rate are not displayed in the display and not taken into account when measuring the consumption. The value for the creep feed rate is entered in the parameter **Flo.Lo**.

11.3.7 Reset of air consumption counter

The air consumption counter is reset in the “Extended functions” menu. To do so the parameter **totAL.r** is selected. As an option the display or the reset of the value is available. To reset the **rES** function is selected. After the reset the counter immediately restarts at zero.

11.3.8 Configuration of the display

In the display configuration menu **CFG.diS** the measuring variables to be displayed in the display are defined. When selecting **oFF** the display goes out after a brief period of time if no entry is made. Any key actuation re-activates the display.

The following display options are available:

- | | |
|---|----------|
| Flow | → Flo |
| Temperature | → °C |
| Air consumption | → totAL |
| Flow 10 s & Temperature 2 s | → Flo.°C |
| Display dark, right decimal point flashes | → oFF |

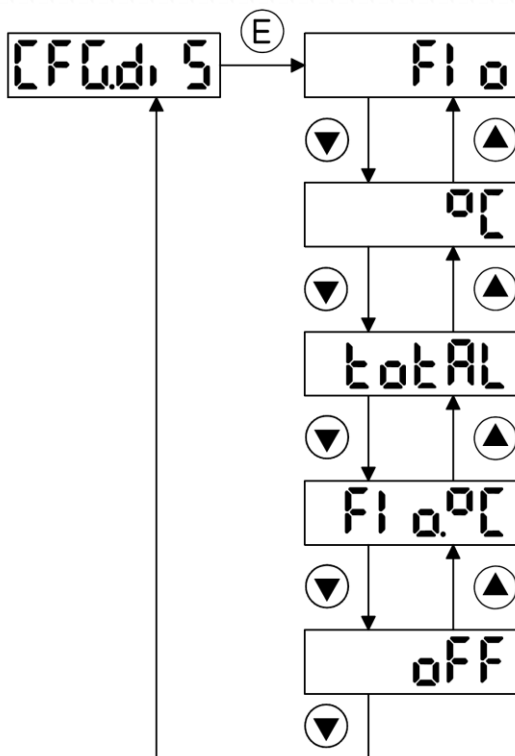

Figure 19: Configuration of the display

11.3.9 Entering the unit for flow measurement

The measuring unit for the flow rate is parameterised in the “Extended functions” menu. The unit is defined in the parameter **Uni.Flo**.

Nl/min → nl-n

Nm³/h → nn3h

Nm/s → nn-S

11.3.10 Locking menu functions

In the locking menu **CFG.Loc** functions can be locked for a user group with only an access code for the main menu.

The locking of access to the parameters **Ou1** and **Ou2** results in the locking of all dependent parameters. These then also no longer appear in the menu.

To lock, **LoC** is selected; parameters to be accessible are assigned **FrEE**.

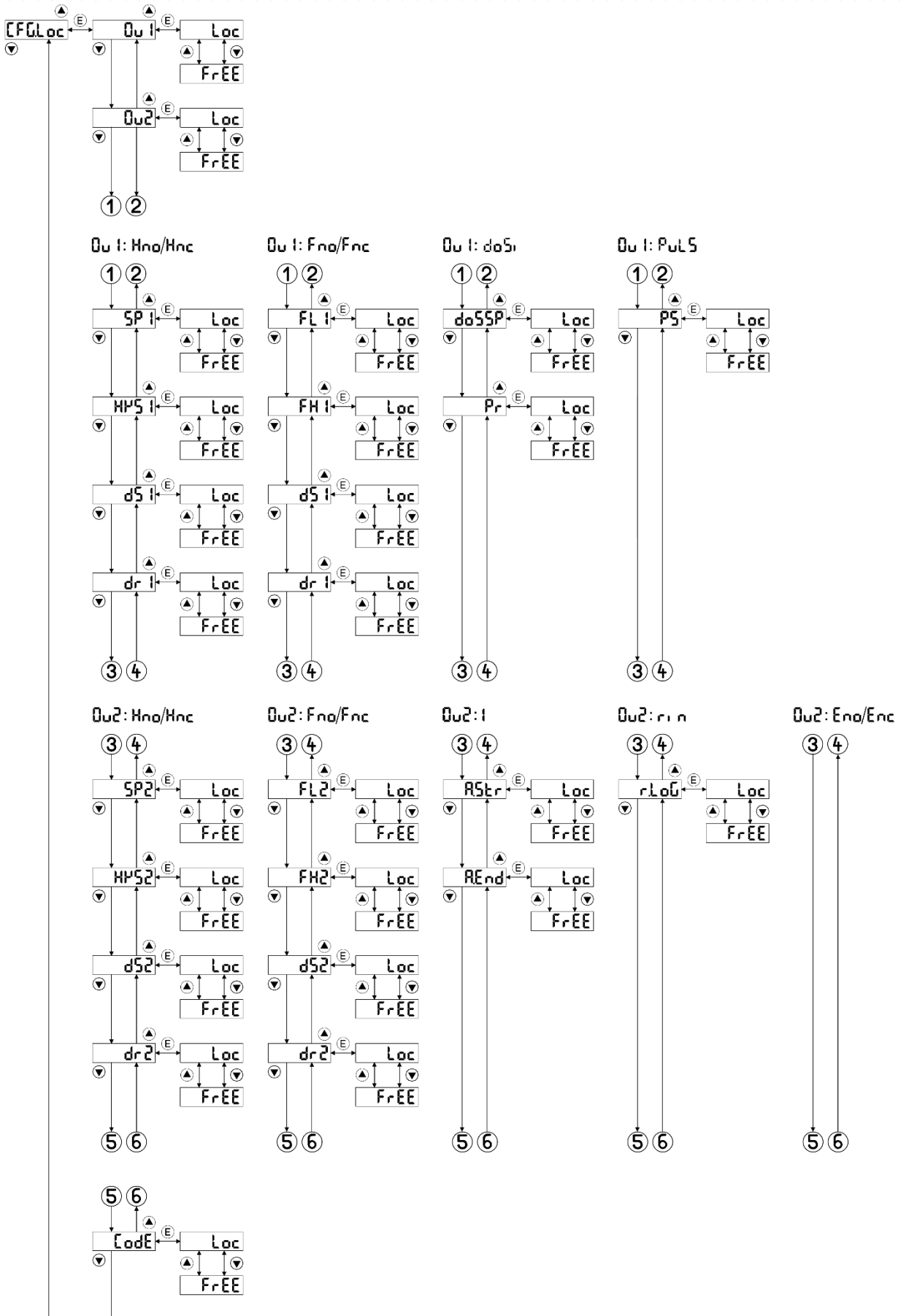

Figure 20: Structure of locking menu

11.3.11 Entering of reference temperature and reference pressure

The parameter values entered here are the reference conditions to which the air flow rate and air consumption values displayed in the display and output via the analogue outputs relate. The following standard conditions are in use:

1013.25 hPa = 1013.25 mbar and 273.15 K = 0 °C (DIN 1343)

1000 hPa = 1000 mbar and 293,15 K = 20 °C (DIN 1945-1)

1013.25 hPa = 1013.25 mbar and 288.15 K = 15 °C (factory setting)

In the compressed air industry the following standard condition is in use: 1000 mbar / 20 °C. The values are entered in **mbar** or **hPa** and °C.

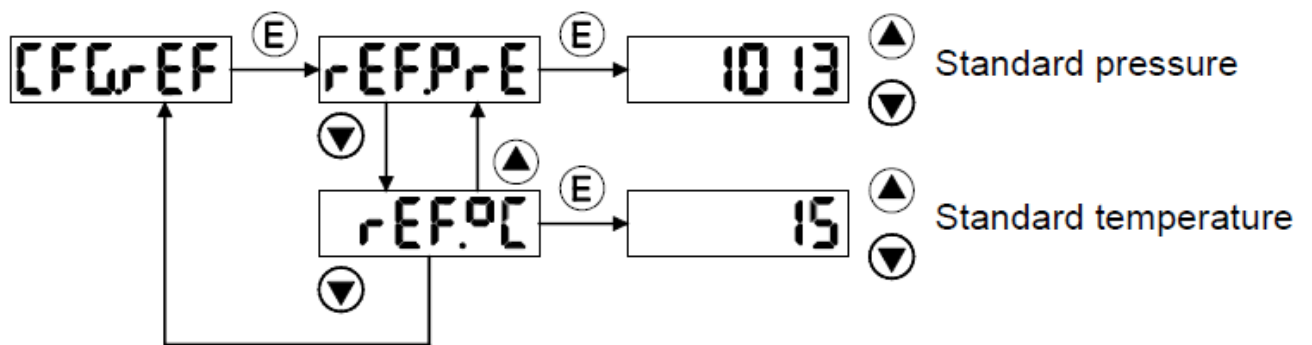

Figure 21: Reference temperature and reference pressure

11.3.12 Entering of customized TAG number

The parameter **APPETAG** can be used for entering a 6 digit device- or plant-specific TAG number.

The following characters can be displayed:

0	0	6	6	A	A	F	F	L	L	t	t
1	1	7	7	b	b	G	G	l	l	U	U
2	2	8	8	C	C	H	H	n	n	u	u
3	3	9	9	c	c	h	h	o	o	Y	Y
4	4			d	d	i	i	P	P	-	-
5	5			E	E	J	J	S	S		

Figure 22: Displayable characters

Note: The characters shown in this manual may differ from the actual characters in the device’s display.

11.3.13 Read out the modification counter

The modification counter **Chn.Cnt** contains the number of parameterisations carried out since the delivery of the sensor. With modifications via the buttons each individual change is registered, with programming via the IO-Link interface each access to the device. The counter cannot be reset.

11.3.14 Change of super code

Access to the “Extended functions” can be restricted for other users by setting up a super code. The super code must not be **0000**. This is the factory setting. The super code also provides access to the main menu.

11.3.15 Reset to factory settings

If it is necessary to reset the device to factory settings, this is possible after reactivation of the device with simultaneously pressing the **E** button and then entering the access code.

If a super code for extended functions has been set up, which differs from the normal access code, it is required for the reset of **all** parameters.

i	Access to parameterisation with code, menu "Extended functions" is not released, super code not known	Code input: Reset to factory settings only for released parameters in the main menu	
	Access to parameterisation with code, super code for access to "Extended functions" is available, super code is known	Code input: Reset to factory settings only for released parameters in the main menu	Super code input: Reset to factory settings for all parameters in the main menu and "Extended functions" menu
	Access to parameterisation with code, super code matches the code	Code or super code input: Reset to factory settings for all parameters in the main menu and "Extended functions" menu	

12 IO-Link

12.1	General.....	Fehler! Textmarke nicht definiert.
12.2	IODD.....	39
12.3	Device data	39
12.4	Process data	40
12.5	Standard commands	41
12.6	On-request data.....	42
12.7	Events.....	49
12.8	Errors messages	49

12.1 General

The device has a communication interface according to the IO link standard. For operation of the interface an IO link master unit with the appropriate functionality is needed.

With the USB IO-Link master set (VY000005) ipf electronic offers all the components required for a comfortable and simple configuration of the flow sensor. Using the master software and the device description for the sensor (IODD) the sensor can be comfortably parameterized. For operating the master and the configuration software use the related operating manual.

Any other IO-Link master meeting the specifications of the IO-Link version 1.1 can also be used.

The sensor is set into IO-Link mode by a wake-up signal as soon as the connection to the IO-Link master has been established. It starts sending process data and is ready to receive commands and parameters.

If the sensor is not connected to a master, it is in SIO mode (standard input/output) and can be used as a standard device with switching and analogue output.

12.2 IODD

The IODD (Input Output Device Description) required for configuration can be downloaded from the Internet page

www.ipf-electronic.com

12.3 Device data

Vendor ID [dez/hex]	780/30C
Device ID [dez].....	2851329

IO-Link Revision 1.1
 Bitrate COM2
 Minimum Cycle Time..... 5.0 ms
 SIO-Mode..... supported
 Block Parameterization supported
 Data storage supported

12.4 Process data

Overall length: 64 Bit

Name	Description	Data type	Bit-Offset	Range of values	Gradient	Unit
Amount of consumption	Amount of consumption since last reset of meter	Float32	32	0...999999E6	0,001	m ³ std
Flow rate	Current air flow rate	UInt16	16	0...1500	0,01	m ³ /h std
Temperature	Current medium temperature	UInt14	2	0...600	0,1	°C
S2	Switching status of S2	Bool	1	true (activated) false (deactivated)		
S1	Switching status of S1	Bool	0	true (activated) false (deactivated)		

12.5 Standard commands

The commands have to be written into index 2. The data type of the value is UInt8.

Value	Description
130	Reset to factory settings
160	Reset of MAX flow rate
161	Reset of MIN flow rate
162	Restart of averaging of flow rate measurement
163	Reset of MAX temperature
164	Reset of MIN temperature
165	Restart of averaging of temperature measurement
166	Reset of air consumption meter
167	Reset of failure code register
168	Storage of air consumption value
169	Reset of dosing/filling pulse

12.6 On-request data

Types of data

- R..... Record 16 bit
- B..... Boolean
- S..... String
- S16..... String 16 Byte
- I16..... Integer16
- U8..... UInteger8
- U16..... UInteger16
- U32..... UInteger32
- U64..... UInteger64

Access

- RW..... Read/Write
- RO..... Read Only
- WO..... Write Only

Index	Bit	Name	Description	Data type	Access	Factory setting	Range of values	Gradient	Unit
12		Device Access Locks		R	RW				
12	1	Data storage		B	RW	0	0: free 1: locked		
12	3	Local parameterization		B	RW	0	0: free 1: locked		
16		manufacturers name		S	RO	ipf electronic gmbh			

17		manufacturers text		S	RO	www.ipf-electronic.com			
18		product name		S	RO	Airflow meter			
19		product ID		S	RO	SL430020			
20		product text		S	RO	Airflow meter			
21		serial number		S	RO				
22		hardware revision		S	RO				
23		firmware revision		S	RO				
24		user identification		S16	RW				
64		OU 1	Operating mode for output S1	U8	RW	1	1: hysteresis function normally open Hno 2: hysteresis function normally close Hnc 3: Window function normally open Fno 4: Window function normally close Fnc 5: dosing function doS 6: pulse function PuLS		
65		OU 2	Operating mode for output S1	U8	RW	1	1: hysteresis function normally open Hno 2: hysteresis function normally close Hnc 3: window function normally open Fno 4: window function normally close Fnc 5: Current output I 7: failure message normally open Eno 8: failure message normally close Enc 9: Signal input Reset rn		
66		SP 1	Limit value switching point S1 flow rate	I16	RW	100	6...1500	0,01	m ³ /h std
67		HYS 1	Flow rate parameter value for hysteresis S1	I16	RW	50	2...500	0,01	m ³ /h std

66	FL 1	Flow rate "low" limit value window operating mode S1	I16	RW	100	6...1498	0,01	m ³ /h std
69	FH 1	Flow rate "high" limit value window operating mode S1	I16	RW	150	8...1500	0,01	m ³ /h std
70	SP2	Flow rate Limit value switching point S2	I16	RW	200	6...1500	0,01	m ³ /h std
71	HYS2	Flow rate parameter value for hysteresis S2	I16	RW	50	2...500	0,01	m ³ /h std
72	FL2	Flow rate "low" limit value window operating mode S2	I16	RW	200	6...1498	0,01	m ³ /h std
73	FH2	Flow rate "high" limit value window operating mode S2	I16	RW	250	8...1500	0,01	m ³ /h std
74	SP 1	Temperature Limit value switching point S1	I16	RW	200	2...600	0,1	°C
75	HYS 1	Temperature parameter value for hysteresis S1	I16	RW	10	2...200	0,1	°C
76	FL 1	Temperature "low" limit value window operating mode S1	I16	RW	200	2...598	0,1	°C
77	FH 1	Temperature "high" limit value window operating mode S1	I16	RW	210	4...600	0,1	°C
78	SP2	Temperature Limit value switching point S2	I16	RW	400	2...600	0,1	°C
79	HYS2	Temperature parameter value for hysteresis S2	I16	RW	10	2...200	0,1	°C
80	FL2	Temperature "low" limit value window operating mode S2	I16	RW	400	2...598	0,1	°C

81	FH2	Temperature "high" limit value window operating mode S2	I16	RW	410	4...600	0,1	°C
82	dS1	Switch-on delay S1	I16	RW	0	0...500	0,1	s
83	dr1	Switch-off delay S1	I16	RW	0	0...500	0,1	s
84	dS2	Switch-on delay S2	I16	RW	0	0...500	0,1	s
85	dr2	Switch-off delay S2	I16	RW	0	0...500	0,1	s
86	A.Str	Flow rate Start value 4 mA Analog output	I16	RW	0	0...1000	0,01	m ³ /h std
87	A.End	Flow rate Final value 20 mA Analog output	I16	RW	1500	500...1500	0,01	m ³ /h std
88	A.Str	Temperature Start value 4 mA Analog output	I16	RW	0	0...400	0,1	°C
89	A.End	Temperature Final value 20 mA Analog output	I16	RW	600	200...600	0,1	°C
90	doSSP	Dosing/filling amount	U64	RW	100	1...5E9	0,001	m ³ std
91	PS	pulse valence	I16	RW	5	1,5,10, 100,1000		l std
92	r.LoG	Configuration of input pin for dosing pulse, Reset of dosing pulse	U8	RW	0	0: rising edge Pos 1: falling edge nEG		
93	Code	Access code, programming, main menu	I16	RW	0	0...9999		
94	SCode	Access code, EF menu and main menu	I16	RW	0	0...9999		
95	FILtEr	Duration of averaging	U8	RW	2	0, 1, 2, 4, 8		s

96		Flo.Lo	Lowest detection range value	16	RW	4	4...100	0,01	m ³ /h std
97		dS	Measurand for display	U8	RW	0	0: Flow rate Flo 1: Temperature °C 2: air consumption totAL 3: Flow rate and temperature in alternation Flo.°C 4: Display off oFF		
98		Uni.SP 1	Unit SP1 or window values 1	U8	RW	0	0: Flow rate Flo 1: Temperature °C		
99		Uni.SP2	Unit SP2 or window values 2	U8	RW	0	0: Flow rate Flo 1: Temperature °C		
100		P-n	Output polarity	U8	RW	0	0: PNP PnP 1: NPN nPn		
101		Uni.ADu	Unit analog output	U8	RW	0	0: Flow rate Flo 1: Temperature °C		
102		LoC	Blocking of parameters	U32	RW	0			
102	0	LoC	Du 1	B	RW	0	0: not locked FrEE 1: locked LoC		
102	1	LoC	Du2	B	RW	0	0: not locked FrEE 1: locked LoC		
102	2	LoC	SP 1	B	RW	0	0: not locked FrEE 1: locked LoC		
102	3	LoC	MYS 1	B	RW	0	0: not locked FrEE 1: locked LoC		
102	4	LoC	FL 1	B	RW	0	0: not locked FrEE 1: locked LoC		
102	5	LoC	FH 1	B	RW	0	0: not locked FrEE 1: locked LoC		
102	6	LoC	dS 1	B	RW	0	0: not locked FrEE 1: locked LoC		
102	7	LoC	dr 1	B	RW	0	0: not locked FrEE 1: locked LoC		
102	8	LoC	doSSP	B	RW	0	0: not locked FrEE 1: locked LoC		

102	9	LoC	dPr	B	RW	0	0: not locked FrEE 1: locked LoC		
102	10	LoC	PS	B	RW	0	0: not locked FrEE 1: locked LoC		
102	11	LoC	SP2	B	RW	0	0: not locked FrEE 1: locked LoC		
102	12	LoC	H4S2	B	RW	0	0: not locked FrEE 1: locked LoC		
102	13	LoC	FL2	B	RW	0	0: not locked FrEE 1: locked LoC		
102	14	LoC	FH2	B	RW	0	0: not locked FrEE 1: locked LoC		
102	15	LoC	dS2	B	RW	0	0: not locked FrEE 1: locked LoC		
102	16	LoC	dr2	B	RW	0	0: not locked FrEE 1: locked LoC		
102	17	LoC	R.Str	B	RW	0	0: not locked FrEE 1: locked LoC		
102	18	LoC	R.End	B	RW	0	0: not locked FrEE 1: locked LoC		
102	19	LoC	r.LoC	B	RW	0	0: not locked FrEE 1: locked LoC		
102	20	LoC	CoDE	B	RW	0	0: not locked FrEE 1: locked LoC		
103		Uni.Flo	Unit displayed flow rate value	U8	RW	0	0: m ³ /h std nn3h 1: l/min std nl-n 2: m/s std nn-5		
104		rEF.PrE	Reference pressure	I16	RW	1013	960...1050	1	hPa
105		rEF.°C	Reference temperature	I16	RW	15	0...25	1	°C
106		Err.C	Failure code	U8	RO	--	--	--	--
107		Chn.cnt	Counter for modifications since fabrication	I16	RO	--	--	--	--

108		Hi.Flo	Maximum flow rate since last reset	I16	RO	--	--	0,01	m ³ /h std
109		Lo.Flo	Minimum flow rate since last reset	I16	RO	--	--	0,01	m ³ /h std
110		24h.Flo	Average flow rate since last reset (max 24 h)	I16	RO	--	--	0,01	m ³ /h std
111		Hi.°C	Maximum temperature since last reset	I16	RO	--	--	0,1	°C
112		Lo.°C	Minimum temperature since last reset	I16	RO	--	--	0,1	°C
113		24h.°C	Average temperature since last reset (max 24 h)	I16	RO	--	--	0,1	°C

12.7 Events

Code	Name	Type	Description
0x4210	T_Ambient_High	Warning	Temperature too high inside of device
0x5000	Hardware failure	Error	failure
0x5110	UB_High	Warning	UB > 30V
0x5111	UB_Low	Warning	UB < 18V
0x7710	Short circuit	Error	Short circuit at OUT2 (WH)
0x8C10	T_Medium_High	Warning	Medium temperature > 60°C
0x8C30	T_Medium_Low	Warning	Medium temperature < 0°C
0x8DF0	Testevent1	Warning	Only for internal tests
0x8DF1	Testevent2	Warning	Only for internal tests

12.8 Error messages

Errorcode	Description
0x8011	index not available
0x8012	sub-Index not available
0x8020	service currently not available
0x8030	parameter outside of valid range
0x8031	parameter above valid range
0x8032	parameter below valid range
0x8033	parameter too long
0x8034	parameter too short
0x8035	function not available
0x8040	invalid parameter

13 Designations (alphabetical order)

Presentation in display	Type	Description	Reference
A			
R.End	Parameter	Final value of analog output 20 mA	Main menu
R.Str	Parameter	Start value of analog output 4 mA	Main menu
APP.TAG	Parameter	TAG-marker	Extended functions
C			
CFG.dIS	Configuration	Configuration of operating mode of display	Extended functions
CFG.LoG	Configuration	Configuration of access	Extended functions
CFG.Out	Configuration	Configuration of operating modes for outputs	Extended functions
Chn.Cnt	Parameter	Contains the number Modification, counter	Extended functions
Code	Parameter	Access code for programming	Main menu
d			
dAtA	Configuration	Configuration of MIN / MAX / average values	Extended functions
doS	Value	Dosing / filling function	Main menu
dPr	Function	Reset of dosing pulse	Main menu
dr l	Parameter	Switch-off delay for output S1	Main menu

dr2	Parameter	Switch-off delay for output S2	Main menu
doSSP	Parameter	Dosing / filling amount	Main menu p. 5
dS1	Parameter	Switch-on delay for output S1	Main menu
dS2	Parameter	Switch-on delay for output S2	Main menu
E			
EF	Function	Call up of „Extended functions“ menu	Main menu
Eno	Value	Monitoring of device failure, output S1 is normally open	Main menu
Enc	Value	Monitoring of device failure, output S1 is normally close	Main menu
Err	Value	Wrong input	
Err.C	Parameter	Contains the failure code	Main menu
F			
FiLteEr	Parameter	Parameterization of filter value	Extended functions
FlO.°C	Value	Alternate display of flow rate and temperature (10 s/2 s)	Extended functions
Fno	Value	Window comparator, output S1/S2 are normally open	Main menu
Fnc	Value	Window comparator, output S1/S2 are normally close	Main menu
FH1	Parameter	„high“ limit value of window comparator for output S1	Main menu
FH2	Parameter	„high“ limit value of window comparator for output S2	Main menu

FL1	Parameter	„low“ limit value of window comparator for output S1	Main menu
FL2	Parameter	„low“ limit value of window comparator for output S2	Main menu
Flo	Value	Flow rate	Main menu
Flo.lo	Parameter	Lower detection limit	Extended functions
H			
H.Flo	Parameter	Maximum value of flow rate	Extended functions
H.°C	Parameter	Maximum value of temperature	Extended functions
Hold	Function	Value remains unchanged	Main menu
Hnc	Value	Limit value monitoring with hysteresis, output S1/S2 are normally open	Main menu
Hno	Value	Limit value monitoring with hysteresis, output S1/S2 are normally close	Main menu
HYS1	Parameter	Hysteresis for output S1	Main menu
HYS2	Parameter	Hysteresis for output S2	Main menu
I			
I	Value	Current output 4...20mA	Main menu
L			
LoE	Value	Parameter locked	Extended functions

Lo.°C	Parameter	Minimum value of temperature	Extended functions
Lo.Flo	Parameter	Minimum value of flow rate	Extended functions
n			
nEE	Value	Reset with negativ edge	Main menu
nPn	Value	NPN, output S1/S2 wired against minus	Extended functions
nl-h	Value	Unit NI/min	Extended functions
nl-nn	Value	Unit NI/min	Extended functions
nn3h	Value	Unit Nm³/h	Extended functions
nn-S	Value	Unit Nm/s	Extended functions
0			
off	Value	Display switches off 10s after last action, heartbeat LED flashes	Extended functions
Ou 1	Parameter	Contains operating mode of output S1	Main menu
Ou 2	Parameter	Contains operating mode of output S2	Main menu
P			
P-n	Parameter	Output logic S1/S2: PNP/NPN	Extended functions
PnP	Value	PNP, output S1/S2 wired against plus	Extended functions
Pos	Value	Reset with positive edge	Main menu

P5	Parameter	Pulse valence	Main menu
PUL5	Value	Operating mode pulse output	Main menu
r			
rEF.°C	Function	Reference temperature	Extended functions
rEF.PrE	Function	Reference pressure	Extended functions
rES	Function	Reset of parameters	
rin	Value	Configuration of reset input for dosing/filling function	Main menu
rLoG	Parameter	Reset logic of dosing/filling function	Main menu
S			
SCode	Parameter	Access code to "Extended functions"	Extended functions
SP1	Parameter	Limit value for output S1	Main menu
SP2	Parameter	Limit value for output S2	Main menu
t			
totAL	Parameter	Air consumption	Extended functions
totAL.r	Function	Reset of consumption counter	Extended functions
U			
Uni.Flo	Parameter	Unit of flow rate	Extended functions

Un.SP1	Parameter	Signal source for output S1 (Hysteresis and window function)	Extended functions
Un.SP2	Parameter	Signal source for output S1 (Hysteresis and window function)	Extended functions
Un.AQw	Parameter	Signal source for analog output	Extended functions
°C	Value	Temperature	Extended functions
24h.Flo	Parameter	Average value of flow rate since last reset (max. 24h)	Extended functions
24h.°C	Parameter	Average value of temperature since last reset (max. 24h)	Extended functions

14 Technical data

14.1 Electrical data

Supply voltage [VDC]	18...30
Current consumption [mA].....	≤ 120
Ambient temperature [°C].....	-10...60
Output 1 and 2.....	PNP/NPN
Output 1	NC/NO
Switching current[mA].....	≤ 150
Output 2	NC/NO
Switching current [mA].....	≤ 150
Analog [mA].....	4...20 (RL ≤ 500 Ω)
Input voltage High-Pegel [VDC]	$9 \leq U_{IN} \leq U_{Supply}$
Input voltage Low-Pegel [VDC].....	$0 \leq U_{IN} \leq 4$
Medium temperature [°C].....	0...60

14.2 Detection of flow rate¹

Measuring range

Flow rate [Nm ³ /h].....	0.04...15.00
Flow rate [Nl/min]	0.5...250.0
Flow velocity [Nm/s].....	0.2...65.5

Deviation²

Of measured value [± %]	4
Of final value of measuring range [± %]	0.5
Repeatability [≤ %].....	2

¹ Definition of air quality according to ISO 8573-1: class 141 (particles-water-oil)

² Under reference conditions

Adjustment ranges

Switching points SP1 and SP2 [Nm ³ /h].....	0.06...15.00
Hysteresis HYS1 and HYS2 [Nm ³ /h].....	0.02...5.00
„Low“ limit values for FL1 and FL2 [Nm ³ /h].....	0.06...14.98
„High“ limit values for FL1 and FL2 [Nm ³ /h].....	0.08...15.00
Start value 4 mA [Nm ³ /h].....	0,00...10.00
Final value 20 mA [Nm ³ /h].....	5.00...15.00
Creeping quantity suppression [Nm ³ /h].....	0.04...1.00
Increment [Nm ³ /h].....	0.02

Switching points SP1 and SP2 [NI/min].....	1.0...250.0
Hysteresis HYS1 and HYS2 [NI/min].....	0.5...83.5
„Low“ limit values for FL1 and FL2 [NI/min].....	1.0...249.5
„High“ limit values for FL1 and FL2 [NI/min].....	1.5...250
Start value 4 mA [NI/min].....	0.0...166.5
Final value 20 mA [NI/min].....	83.5...250.0
Creeping quantity suppression [NI/min].....	0.5...16.5
Increment [NI/min].....	0.5

Schaltpunkt SP1 und SP2 [Nm/s].....	0.3...65.5
Hysterese HYS1 und HYS2 [Nm/s].....	0.1...21.8
„Low“ limit values for FL1 and FL2 [Nm/s].....	0.3...65.4
„High“ limit values for FL1 and FL2 [Nm/s].....	0.4...65.5
Start value 4 mA [Nm/s].....	0.0...43.7
Final value 20 mA [Nm/s].....	21.8...65.5
Creeping quantity suppression [Nm/s].....	0.2...4.4
Increment [Nm/s].....	0.1

14.3 Air consumption metering

Pulse valency [NI/min] / duration of pulse [ms]	1/5, 5/10, 10/50, 100/100, 1000/1000
Dosing / filling amount [Nm ³].....	0.001...5.000.000
Increment [Nm ³ /h].....	0.001

14.4 Temperature monitoring

Measuring range

Temperature [°C]0...60

Deviation³

Of measured value [± °C]2

Adjustment range

Switching points SP1 and SP2 [°C]0.2...60.0

Hysteresis HYS1 and HYS2 [°C]0.2...20.0

„Low“ limit values for FL1 and FL2 [°C]0.2...59.8

„High“ limit values for FL1 and FL2 [°C]0.4...60.0

Start value 4 mA [°C]0.0...40.0

Final value 20 mA [°C]20.0...60.0

Increment [°C]0.2

14.5 Response times

Reaction time [s]≤ 0.2

Averaging time [s]0...8

Switch-on delay OUT1/OUT2 [s]0.0...50.0

Switch-off delay OUT1/OUT2 [s]0.0...50.0

Increment [s]0.5

14.6 IO-Link-Device

Version1.1

Data transfer rateCOM2 (38.4
kBaud)

Device-ID [decimal]2851329

³ Minimum flow rate: 30% of final value of measuring range

Cycle time min. [ms]..... 5.0
Process data [Byte]..... 8

14.7 Mechanical data

Pressure resistance [bar]..... 16
Degree of protection IP 54

Material of sensor (medium touched)

Housing..... Aluminum, PA
Inlet / Outlet path..... 1.4301, AFM 34
Measuring elements..... Ceramic, glass

Material housing

Cover PBT
Front label Polyester
Connector..... 1.4305
Connector insert..... PA