

UT120021

PRODUCT: ultrasonic diffuse reflection sensor, analog
DESIGN: 12 M12x1, with beam columnator

- very small sonic cone angle
- filling level monitoring in small containers from approx. Ø10mm possible
- integrated amplifier
- adjustment of the switch-point via teach-in
- teach-in via white wire (PIN 2)
- one yellow and one red LED for receiving display and teach-in
- housing made of nickel-plated brass
- connection with M12-connector
- delivery in storage box

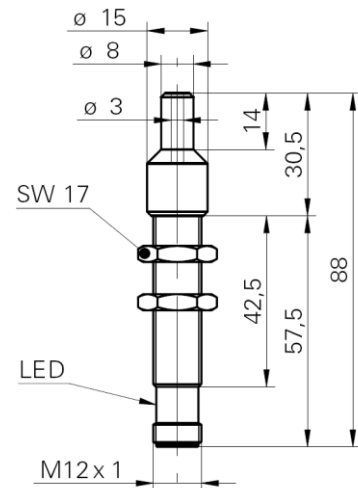

technical data

operating voltage	15 ... 30V DC
current consumption (w/o load)	< 35mA
max. current load	≤ 20mA
analog output	0 ... 10V
measuring range (teachable)	2 ... 82mm
dead zone	2mm
repeatability	≤ 0.5mm
resolution	≤ 0.3mm
receiving display	LED yellow / red
response / decay time	< 30msec
ultrasonic frequency	380kHz
sonic cone angle	6°
ambient temperature	-10 ... +60°C
system of protection	IP67 (EN 60529)
housing material	brass, nickel-plated
electrical connection	M12-connector, 4pin
fitting cable socket	e.g. VK200321

electrical connection

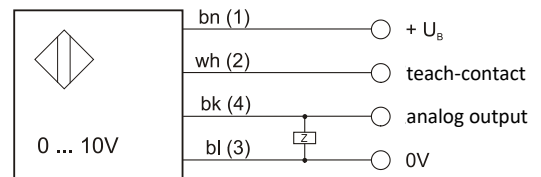

bn= brown, wh = white, bk = black, bl = blue
 terminal markings of the cable socket in brackets

measuring range adjustment (teach-in)

1. Connect voltage supply and analog output, the teach-in process must take place within 5 minutes time.
2. Connect the teach-contact (white wire / PIN 2) with +U_B for until the yellow and the red LED are flashing alternating. After this open the connection.
3. The LED flashes red. Bring the object to be detected into the position where the analog output should output 0V. Afterwards connect the teach-contact shortly (< 1sec) with +U_B.
4. The LED flashes yellow. Bring the object to be detected into the position where the analog output should output 10V. Afterwards connect the teach-contact shortly (< 1sec) with +U_B.
5. The sensor confirms the successful teach-process by flashing of both LEDs for 2sec.

important notes:

- To prevent the adjustment of the sensor from being altered without authorization the teach-in lock comes into action five minutes after switch-on or after the teach-process. To start a new teach-in processes please disconnect the voltage supply and perform the points 1 to 5 with the new distances.
- Inside of the taught-in limits the yellow LED lights up during operation. Above the sensor-distant limit no LED lights up. Below the sensor-near limit the red LED lights up.
- To reset the sensor to the factory settings, disconnect the sensor from the operating voltage in order to deblock the teach-contact. Reconnect the voltage and connect the teach-contact with +U_B until the yellow and red LED are flashing fast.
- The sensor has a so-called start-up drift. This drift is compensated approx. 15min after connecting the operating voltage.

Warning: Never use the devices in applications where the safety of a person depends on their functionality!