

UT189023

Ultrasonic sensors
Diffuse reflection sensor

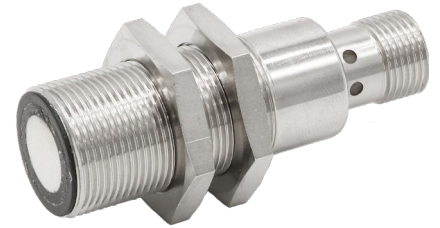

- / Measuring range adjustable via teach-in
- / Analog output
- / M12-connector

IO-Link interface
4 ... 20mA / 0 ... 10V switchable

TECHNICAL DATA

Scanning range	150 ... 1500mm
Operating voltage U_B	18 ... 30V DC
Analog output	0 ... 10V, 4 ... 20mA switchable, not reverse polarity protected
Load resistance (4 ... 20mA)	< 400Ω
Load resistance (0 ... 10V)	> 10kΩ
Switching output (adjustable via IO-Link)	Push-Pull, no/nc switchable
Output current (max. load)	150mA
Short-circuit proof	+
Reverse polarity protected	+
Voltage drop	2.0V DC
Switching frequency	5Hz
Current consumption (without load)	40mA
Standard measuring plate	200 x 200mm
Resolution	1.0mm
Repeatability	1mm
Linearity error	0.5%
Mounting distance (sensor to sensor)	700mm
Setting	Teach-In
Carrier frequency	400kHz
Protection class	III
Insulation dielectric strength	500V
Protection class (EN 60529)	IP 67
Material (housing)	Brass nickel plated
Temperature (operation)	-25 ... +70°C
Temperature drift	0.2%/K (uncompensated)
Connection	M12-connector 4-pole
Connection accessories	e.g. VK200325

Connection

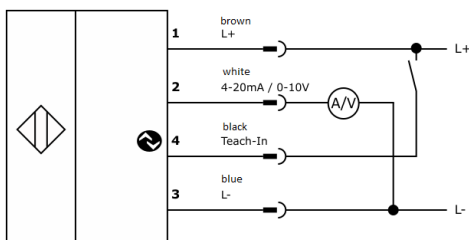

Dimensional drawing

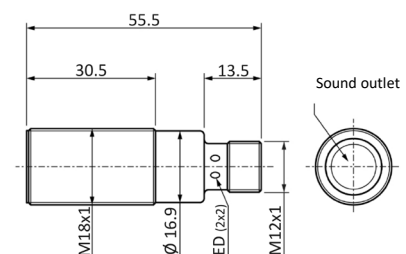

Approved use

The ultrasonic diffuse-reflection sensor are used as part of a higher-level overall system for the contactless detection of objects.

Function

The ultrasonic diffuse-reflection sensors work on the principle of time-of-flight measurement. The device transmits a pulse train, which is then reflected by an object. The device detects the reflected wave and measures the time that has elapsed between the transmission and reception processes. This time is used to determine the distance between the sensor and the object. If the results correspond to the specified values, the analog output outputs a value proportional to the distance and the switching output is set accordingly.

Mounting

The sensor may be mounted in any position. Make sure that it is mounted in a vibration-free and vibration-damping manner. Also protect the device against mechanical loads such as shocks or impacts.

It is imperative that the transducer surface as well as the area of the detection lobe are kept free. Make sure that there are no interfering objects between the sensor and the target object inside the lobe. Otherwise, it is possible that the interfering object will cause false switching. Also avoid positioning two or more ultrasonic sensors opposite each other.

Temperature

The speed of sound in air depends on the temperature. Operation outside the specified ambient temperature is not allowed. A temperature compensation can be switched on via IO-Link.

When temperature compensation is activated, the sensor requires about 15 minutes of warm-up time after a cold start; only then are the measured values reproducible.

Transmission angle of the object in diffuse mode

Objects with a smooth surface are reliably scanned up to a tilting angle of approx. 5° at 150mm and approx. 2° at 1500mm scanning range. The maximum permissible tilting angle increases for objects with rough or highly structured (grained) surfaces.

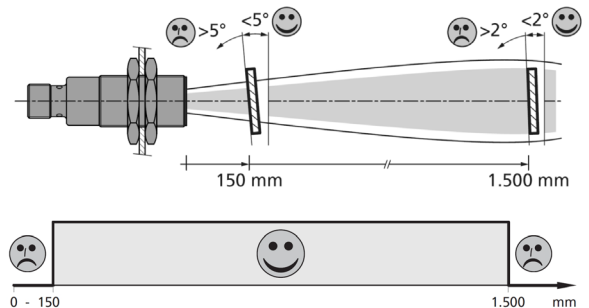

Blind range in touch mode

The range of 0 ... 150mm in front of the sensor corresponds to the ultrasonic typical blind range.

Distance measurements are not possible in the blind range!

The maximum scanning distance 1500 mm.

Sound cone

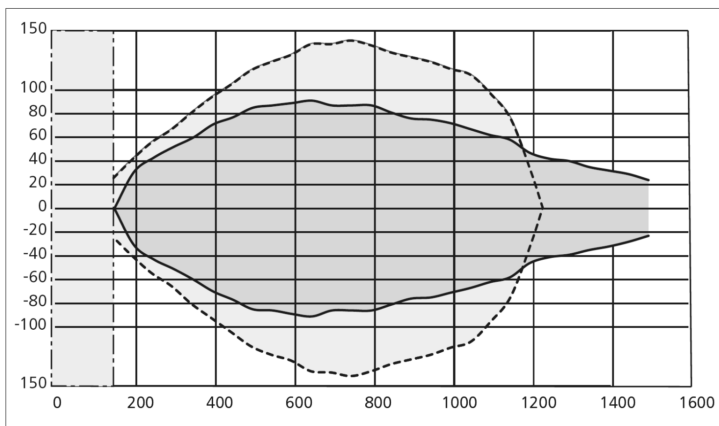

— Plate 200 x 200mm
 - - - - Round bar Ø25mm

Cleaning

For cleaning a soft cloth moistened with soapy water is recommended.

Commissioning and setting

The measuring range is taught-in and the analog output is switched over by connecting the black wire (PIN 4) to the operating voltage (PIN1).

The teach process is aborted after 20 seconds (Time Out function).

Make sure that the object to be detected is always within the scanning range limits (150 ... 1500mm). The distance between value 1 and value 2 must be at least 100mm.

1. Teach-in of the measuring range

1. Position the object at the point where the analog value should be 4mA or 0V.
2. Connect the black wire to the operating voltage for between 0.1 and 2 seconds. The LED is flashing with approx. 1Hz.
3. Position the object at the point where the analog value should be 20mA or 10V.
4. Connect the black wire to the operating voltage for between 0.1 and 2 seconds.
5. The analog output now operates within the defined measuring limits.

2. Changing the output function

1. Connect the black wire to the operating voltage for longer than 6 seconds.
2. The physical quantity of the analog output is changed (instead of current output 4 ... 20mA voltage output 0 ... 10V or vice versa).

Note: Be aware that a considerably larger load resistance is required for operation as a voltage output (see technical data). It is therefore recommended to disconnect the analog output before each change of the output function to avoid device damage

3. LED display after each teach process

If the status LED is flashing twice, the teach process was successful and the sensor is working with the new values.
If the status LED is flashing four times, the teach process has been aborted or the time window of 20 seconds has been exceeded. The sensor operates with maximum measuring range.

On the following page the descriptions are shown again graphically.

The following additional settings can be made using the IO-Link interface:

Measuring ranges < 100mm

Function of the black wire (PIN 4): Teach-in of the analog output
Switching output (push-pull, PNP or NPN)
Synchronization (see "master-slave function" on page 4)
Multiplex (see "master-slave function" on page 4)
If "switching output" is activated, the switching mode, switching function and hysteresis can also be set

Analog output: 0 ... 20mA, 4 ... 20mA, 0 ... 10V, disable

Teach switching points (the state of the switching output is always output via IO-Link)

Switch-on and switch-off delay for switching output

Restore factory settings

1. Teach-in of the measuring range

2. Changing the output function (4 ... 20mA - 0 ... 10V)

3. LED display after each teach process

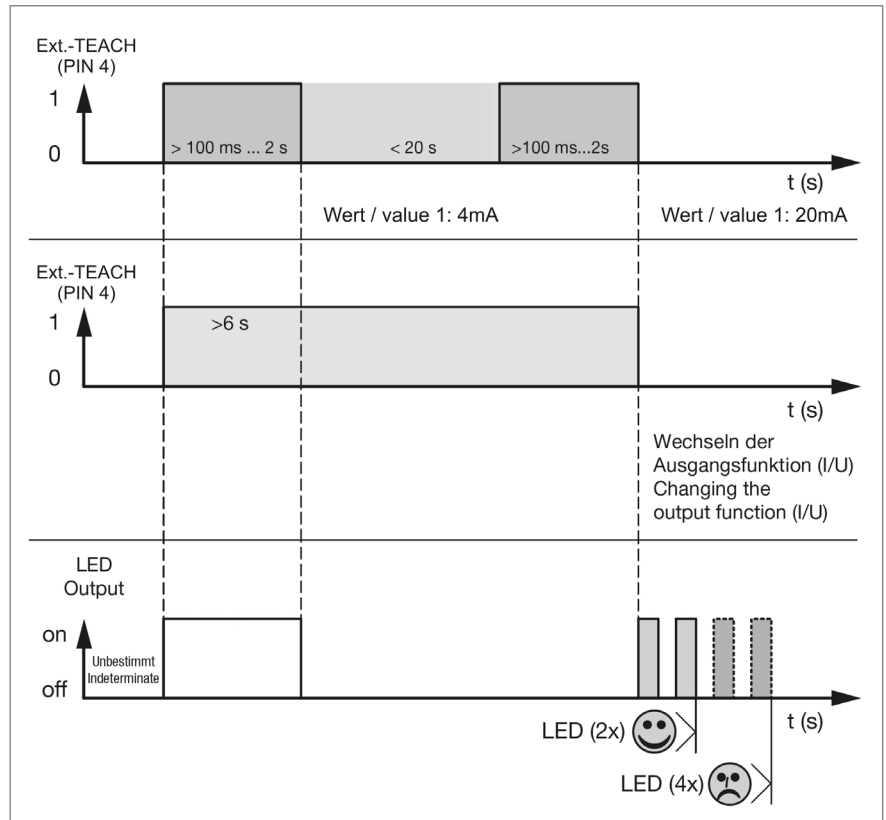

Master-/slave funktion

With the help of this function, up to 10 sensors of the same type can be operated in parallel.

To do this, configure the devices accordingly via IO-Link. Define one sensor as the master and all others as slaves. The master must be assigned the highest number in the network.

Then connect the black wires (PIN 4) with each other (see connection diagram).

The following operating modes can be selected:

1. Synchronous operation: The transmission pulse of all sensors occurs simultaneously with synchronized evaluation. Select this function for monitoring large areas.
2. Multiplex operation: The transmission pulses of the sensors are time-delayed in a defined sequence. The devices can thus no longer influence each other, smaller distances between them are possible.

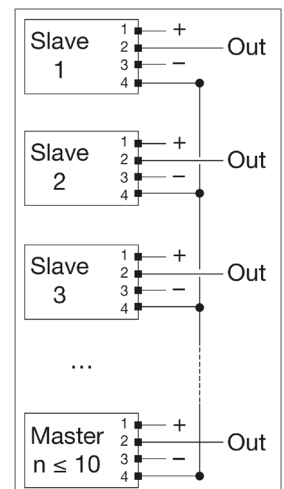

Note: Resetting to the factory setting is only possible via IO-Link.

SAFETY INSTRUCTIONS:

Before commissioning, please make sure that all safety instructions listed in the product documentation, if applicable, have been observed!

In case of direct impact on personal safety, the use of these products is prohibited.