

dimensions **53 x 99.5 x 42.4mm**

camera sensor operating distance **variable**

- ✓ for C-mount lenses
- ✓ color determination and arrangement
- ✓ integrated flash controller
- ✓ short set-up times because of up to 255 check programs with up to 32 feature checks per sensor
- ✓ simple program change via control inputs, software or web-interface
- ✓ codeable, digital outputs for up to 5 status signals
- ✓ stand-alone solution
- ✓ robust metal housing
- ✓ ambient light shielding
- ✓ process interface

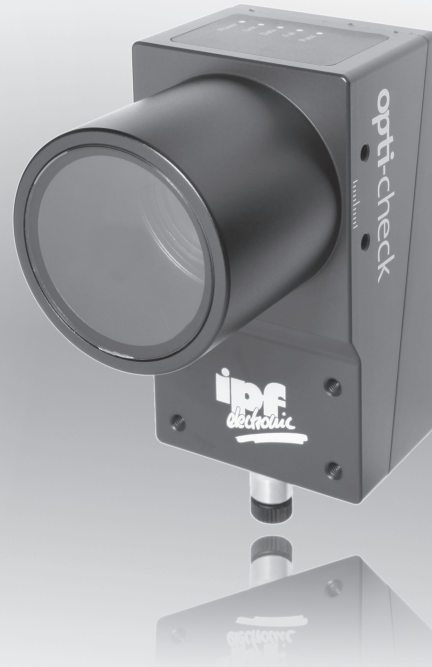

**fully integrated camera system
C-mount connection, contour-based**

	Color	DC —	PNP —	Ethernet
---	-------	---------	----------	----------

description

In addition to a range of functions, the contour-based color camera sensors of the 'opti-check' series are characterized by speed and a high level of ambient light shielding. Possible applications range from classic optical sensors (through-beam sensors and diffuse reflection sensors) through to industrial image processing (computer-supported camera systems). For tasks that require a variable operating distance or various dimensions and illumination of the lens coverage, we offer the **OC53** with a C-mount lens mount. Through the numerous choices for a lens matched to the application and appropriate illumination (not integrated), this camera sensor is always the first choice when great flexibility is required. Thanks to the integrated flash controller, external illumination is supplied via the **OC53**. This makes external flash controllers a thing of the past. Using the simple user interface, it only takes a few steps to

configure the sensor. From various functional groups (part location, geometry, feature comparison) the user can select and combine feature checks. During the manufacturing process, the integrated web interface can be accessed by means of the web browser in order, for example, to carry out subsequent parameterization.

application examples

- ▶ checking a contour testing of mechanical components, e.g. plastic screws, nuts and metal rings
- ▶ completeness check (e.g. with circuit boards)
- ▶ evaluation of installation positions of mounted assemblies
- ▶ querying parts and differentiating different grades in packaging (present / incorrect / absent)
- ▶ evaluation of printing (presence / quality)
- ▶ position checking of markings and imprints
- ▶ feeding of components (position correct / incorrect)

	OC539820	OC539821
article no.	OC539820	OC539821
resolution	640 x 480px	1280 x 960px
image sensor	1/4" CCD, color	1/3" CCD, color
focal length	variable	variable
measuring time	50 fps	12 fps

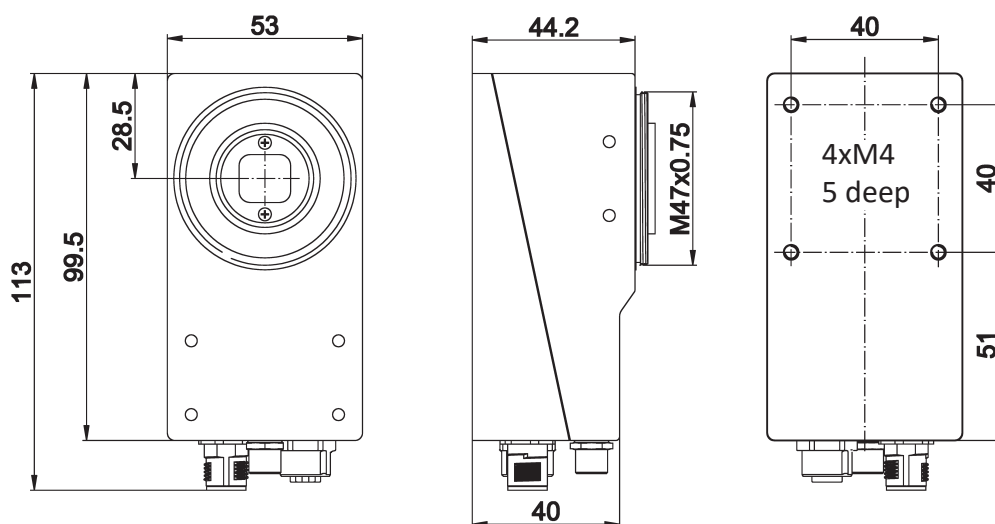

TECHNICAL DATA

resolution	640 x 480px/ 1280 x 960px
operating voltage	18 ... 30V DC
power consumption	typ. 5W
output (process)	pass / fail 1 ... 5, flash sync, alarm, camera ready, output enable
output current (max. load)	100mA per output
input	trigger, job selection, external teach, encoder(CH-A, CH-B) 500kHz
input voltage	8 ... 30V DC
setting	via software (included in the scope of delivery)
output (flash controller)	flash controller: 12 or 24V DC permanent, I=800mA 24V or 48V DC pulsed, I=4A flash time: 1ms (duty cycle max. 1:10)
status display	5 x LED
short.circuit protection	+
reverse polarity protection	+
dimensions	53 x 99.5 x 38mm
material (housing)	aluminum
material (optics)	PMMA
temperature (operating)	+5 ... +50°C
humidity (operating)	0 ... 90% non condensing
degree of protection (EN 60529)	IP67 (with protective lens housing)
vibration resistance	IEC 60068-2-6, IEC 60068-2-64
shock resistance	EN 60068-2-27
connection	supply/signals: M12-connector 12-pin, flash controller: M8-connector 4-pin
interface	Ethernet/Profinet: M12-connector 4-pin
connection accessories	e.g. VK205C25 (supply/signals) / e.g. VK208F25 (Ethernet/Profinet)
accessories	protective lens housing: AO000398 (included in the scope of delivery), lens e.g. AO000544 , protective lens housing: AO000399 , light z.B. ES350120

article no.	OC539H20	OC539H21
resolution	640 x 480px	1280 x 960px
image sensor	CCD (1/4")	CCD (1/3")
focal length	variable	variable
measuring time	116 fps	31 fps

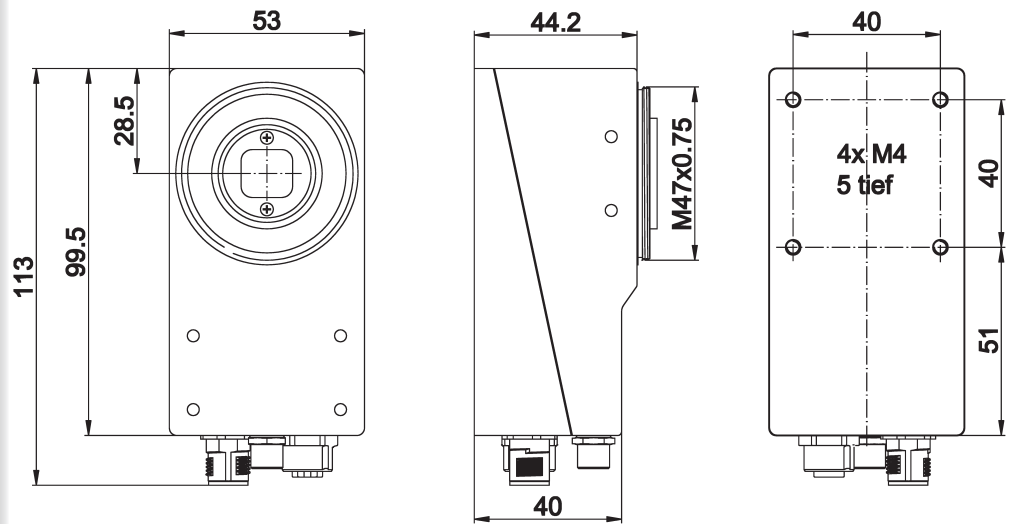

TECHNICAL DATA

resolution	640 x 480px/ 1280 x 960px
operating voltage	18 ... 30V DC
power consumption	typ. 5W
output (process)	pass / fail 1 ... 5, flash sync, alarm, camera ready, output enable
output current (max. load)	100mA per output
input	trigger, job selection, external teach, encoder (CH-A, CH-B) 500kHz
input voltage	8 ... 30V DC
setting	via software (included in the scope of delivery)
output (flasg controller)	flash controller: 12 or 24V DC permanent, I=800mA 24V or 48V DC pulsed, I=4A flash time: 1ms (duty cycle max. 1:10)
status display	5 x LED
short-circuit protection	+
reverse polariyt prtction	+
dimensions	53 x 99.5 x 38mm
material (housing)	aluminum
material (optics)	PMMA
temperature (operating)	+5 ... +50°C
humidity (operating)	0 ... 90% non condensing
degree of protection (EN 60529)	IP67 (with protective lens housing)
vibration resistance	IEC 60068-2-6, IEC 60068-2-64
shock resistance	EN 60068-2-27
connection	supply/signals: M12-connector 12-pin, flash controller: M8-connector 4-pin
interface	Ethernet/Profinet: M12-connector 4-pin
connection accessories	e.g. VK205C25 (supply/signals) / e.g. VK208F25 (Ethernet/Profinet)
accessories	protective lens housing: AO000398 (included in the scope of delivery), lens e.g. AO000544 , protective lens extension: AO000399 , light e.g. ES350120

article no.	OC539820	OC539821	OC539H20	OC539H21
resolution	640x480px	1280x960px	640x480px	1280x960px
process interface				
TCP/IP (Ethernet)	x	x	x	x
Profinet			x	x
part location on				
contours	x	x	x	x
edges	x	x	x	x
circles	x	x	x	x
text lines	x	x	x	x
geometry				
distance	x	x	x	x
circle	x	x	x	x
angle	x	x	x	x
count edges	x	x	x	x
point position	x	x	x	x
edge contour			x	x
feature comparison				
count contour points	x	x	x	x
comparisons of contour	x	x	x	x
brightness	x	x	x	x
contrast	x	x	x	x
area size	x	x	x	x
count areas	x	x	x	x
pattern comparison	x	x	x	x
color determination	x	x	x	x
color arrangement	x	x	x	x

AO000398 protective lens housing

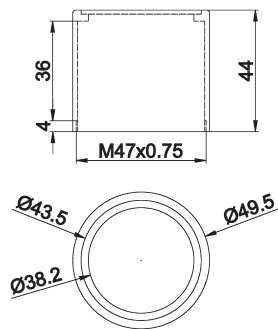

AO000399 protective lens extension

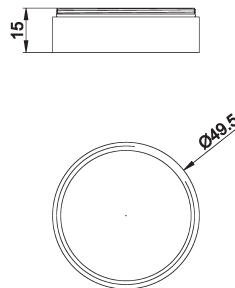

ACCESSORIES

article no.	description
AO000371	adapter plate for installation on tripods
AO000388	mounting plate
AO000389	mounting bracket
AO000398	protective lens housing (included in the scope of delivery)
AO000399	protective lens extension
AO000522	mounting bracket 53 with heat sink for Profinet devices

This data sheet contains the standard versions only. Kindly request the availability of other output and connection versions. We will be pleased to supply the matching cable socket for your devices with connector. Please refer to the list in catalog chapter „accessories“ under „cable sockets **ipf-SENSORFLEX®**“ or search our website for www.ipf-electronic.com for „VK“.

Warning: Never use these devices in applications where the safety of a person depends on their functionality.

This data sheet as well as your personal contact can be found at www.ipf-electronic.com

connection

M12-connector 12-pin, process

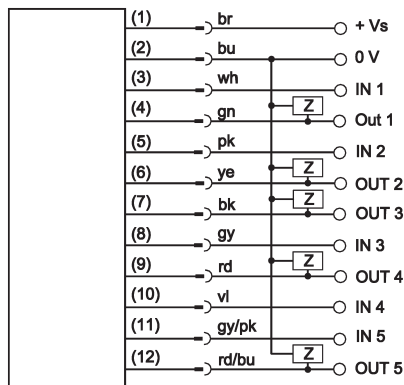

assignment

PIN	color	assignment	open cable end
1	brown	PWR	18 ... 30V DC
2	blue	Ground	0V
3	white	IN 1	trigger
4	green	OUT 1	digital output 1
5	pink	IN 2	digital input 2
6	yellow	OUT 2	digital output 2
7	black	OUT 3	digital output 3
8	gray	IN 3	digital input 3
9	red	OUT 4	digital output 4
10	violet	IN 4	digital input 4
11	gray/pink	IN 5	digital input 5
12	red/blue	OUT 5	digital output 5

M12-connector 4-pin, Ethernet

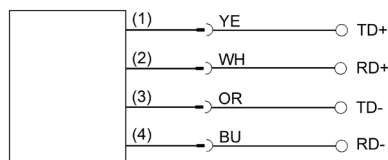

assignment

PIN	Farbe	Belegung
1	yellow	TD +
2	white	RD +
3	orange	TD -
4	blue	RD -

M8-connector 4-pin, flash controller

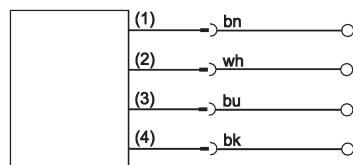

assignment

PIN	color	assignment
1	brown	24 bzw. 48V DC (pulsed)
2	white	12 bzw. 24V DC (permanent)
3	blue	ground
4	black	flash sync.

connections

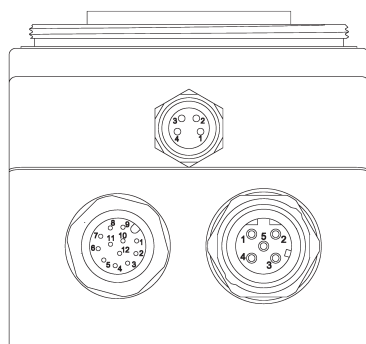

Note: Voltage outputs can be configured via software

LED-status displays
Ethernet

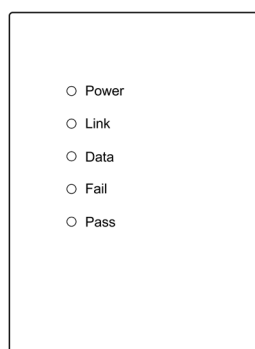

LED-status displays
Profinet

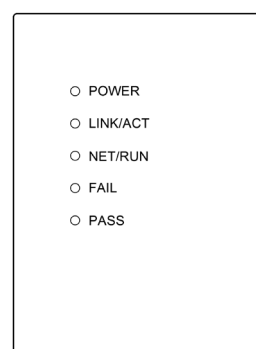

Power	LED yellow	operation
Link/ACT	LED yellow	network
Data/NET RUN	LED orange	data
Fail	LED red	no test
Pass	LED green	test passed



NOTES

A large grid area for taking notes, consisting of a 30x30 grid of small squares. The grid is empty and occupies the majority of the page below the 'NOTES' header.