



- ▶ norm version
- ▶ fiber optics version

NOTES

A large grid area for taking notes, consisting of a 30x30 grid of small squares. The grid is empty and occupies the majority of the page below the 'NOTES' header.

dimensions **M34 x 1.5mm**

measuring range diffuse light **10 ... 60mm**

transmitted light **dependent on fiber optics**

- ✓ **color and grayscale detection**
- ✓ **extremely high switching frequency 30kHz**
- ✓ **suitable for industrial use**
- ✓ **switchable brightness control**
- ✓ **temperature-compensated**
- ✓ **several TEACH options (button, PLC or PC)**
- ✓ **various algorithms can be activated**
- ✓ **color diagram display under Windows**
- ✓ **fiber optic versions can also be used in explosion-hazardous areas**

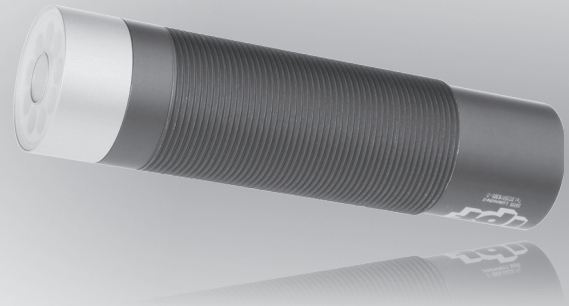

**store up to 31 reference colors
true color detection**



description

ipf color sensors make it possible to distinguish between very similar shades of color with a high level of accuracy. With the devices of this series, we offer a family of color sensors specifically designed for True Color detection (“human color reception”) and a high switching frequency. With the help of pulsed white-light LEDs, a light spot is projected onto the surface that is to be controlled. Part of the light reflected by the measurement object is now directed to a color-sensitive detector element by means of receiving optics. The received light is thereby split according to the 3-color-range method (red, green, blue) as well as by intensity. The devices can be operated both in alternating-light mode with high insensitivity to ambient light as well as in constant-light mode with high scanning frequency (30 kHz) with integrated or external light source. Illumination can be switched off via the Windows software included in the scope of delivery, thereby making possible the color and brightness inspection of self-luminous objects, such as LEDs, vehicle tail lights, halogen lamps or even fluorescent lamps. Devices with UV light source enable the detection and differentiation of fluorescent colors; the use of polarizing filters or diffuse illumination variants allows highly glossy surfaces to be detected.

Up to 31 colors can be output via the 5 digital outputs. With the help of the various front ends, operating distances from nearly 0 to 500 mm can be achieved with detection ranges from Ø 0.5mm to approx. Ø 100mm. The use of fiber optic versions allows scans to be performed in explosion-hazardous areas.

The color sensors are configured via the serial interface (RS232) with converters for USB or Ethernet under Windows®. Up to 31 colors can thereby be taught and stored in the sensor with the option to configure individual evaluation tolerances for each of these colors.

application examples

- ▶ monitoring the cover color of installation parts
- ▶ color inspection of painted components, imitation leathers, plastics and textiles in car interiors
- ▶ ejection of faulty parts based on color markings
- ▶ material sorting using color markings
- ▶ monitoring the sequence of connector strands
- ▶ trigger sensor in the printing industry (print-mark detection)
- ▶ detection of the color of inserts in production systems
- ▶ color differentiation of glass panes



article-no.
version
sensing range

OF340140
diffuse
10 ... 60mm

OF340180
fiber optics
dependent on fiber optics

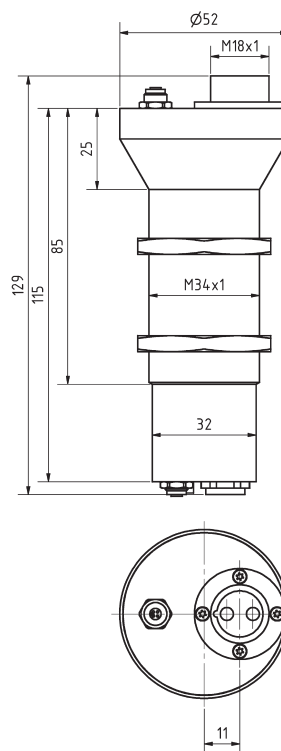
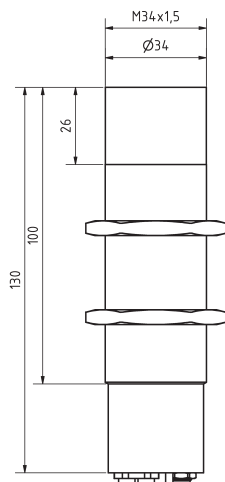

TECHNICAL DATA

sensing range	10 ... 60mm	dependent on fiber optics
output signal	5 x pnp/npn, no/nc	5 x pnp/npn, no/nc
light spot size	Ø 20mm at 40 mm distance	-
operating voltage	24V DC ±10%	24V DC ±10%
current consumption (w/o load)	320mA	320mA
output current (max. load)	≤ 100mA	≤ 100mA
switching frequency	≤ 30kHz	≤ 30kHz
transmitting element (pulsed)	white light LED	white light LED
display (signal)	5x yellow LED	5x yellow LED
setting	teach-in: button + input + software	teach-in: button + input + software
short-circuit protection	+	+
reverse polarity protection	+	+
pulse stretching	0 ... 100ms	0 ... 100ms
dimensions	M34x1.5	M34x1.5
housing material	aluminum, anodized	aluminum, anodized
operating temperature	-20 ... +55°C	-20 ... +55°C
degree of protection (EN 60529)	IP64	IP64
connection	PLC: 8-pin flange socket	PLC: 8-pin flange socket
connection accessories	2m PLC cable e.g. VK207B45	2m PLC cable e.g. VK207B45
interface	RS232	RS232
connection	PC: 5-pin flange socket	PC: 5-pin flange socket
connection accessories	2m PC cable, e.g. VK207U44	2m PC cable, e.g. VK207U44

dimensions **65 x 65 x 42mm**

measuring range diffuse light **10 ... 60mm**

transmitted light **dependent on fiber optics**

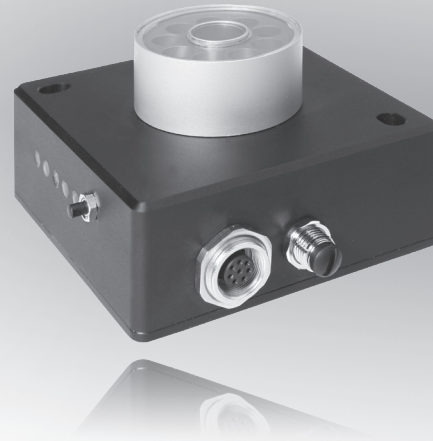

**store up to 31 reference colors
true color detection**

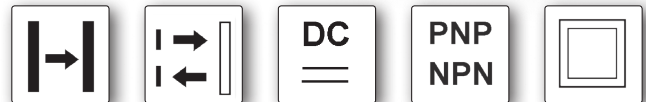

description

ipf color sensors make it possible to distinguish between very similar shades of color with a high level of accuracy. With the devices of this series, we offer a family of color sensors specifically designed for True Color detection (“human color reception”) and a high switching frequency.

With the help of pulsed white-light LEDs, a light spot is projected onto the surface that is to be controlled. Part of the light reflected by the measurement object is now directed to a color-sensitive detector element by means of receiving optics. The received light is thereby split according to the 3-color-range method (red, green, blue) as well as by intensity. The devices can be operated both in alternating-light mode with high insensitivity to ambient light as well as in constant-light mode with high scanning frequency (30 kHz) with integrated or external light source.

Illumination can be switched off via the Windows software included in the scope of delivery, thereby making possible the color and brightness inspection of self-luminous objects, such as LEDs, vehicle tail lights, halogen lamps or even fluorescent lamps. Devices with UV light source enable the detection and differentiation of fluorescent colors; the use of polarizing filters or diffuse illumination variants allows highly glossy surfaces to be detected.

Up to 31 colors can be output via the 5 digital outputs. With the help of the various front ends, operating distances from nearly 0 to 500 mm can be achieved with detection ranges from \varnothing 0.5mm to approx. \varnothing 100mm. The use of fiber optic versions allows scans to be performed in explosion-hazardous areas.

The color sensors are configured via the serial interface (RS232) with converters for USB or Ethernet under Windows®. Up to 31 colors can thereby be taught and stored in the sensor with the option to configure individual evaluation tolerances for each of these colors.

application examples

- ▶ monitoring the cover color of installation parts
- ▶ color inspection of painted components, imitation leathers, plastics and textiles in car interiors
- ▶ ejection of faulty parts based on color markings
- ▶ material sorting using color markings
- ▶ monitoring the sequence of connector strands
- ▶ trigger sensor in the printing industry (print-mark detection)
- ▶ detection of the color of inserts in production systems
- ▶ color differentiation of glass panes



article-no.
version
sensing range

OF650140
diffuse
10 ... 60mm

OF650180
fiber optics
dependent on fiber optics

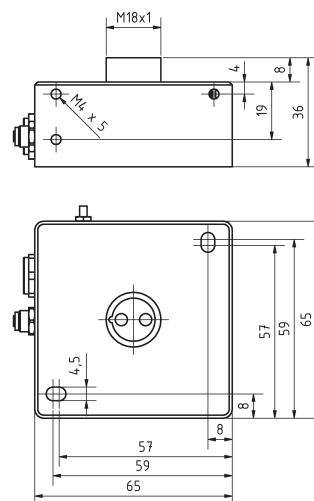
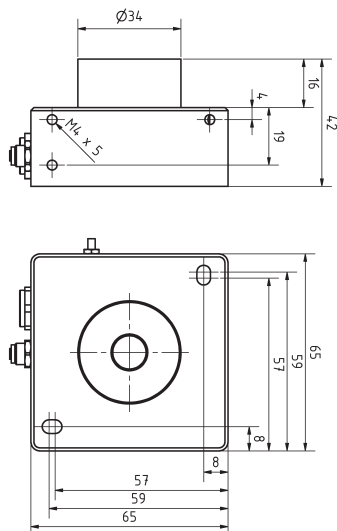

TECHNICAL DATA

sensing range	10 ... 60mm	dependent on fiber optics
output signal	5 x pnp/npn, no/nc	5 x pnp/npn, no/nc
light spot size	Ø 20mm at 200 mm distance	-
operating voltage	24V DC ±10%	24V DC ±10%
current consumption (w/o load)	320mA	320mA
output current (max. load)	≤ 100mA	≤ 100mA
switching frequency	≤ 32kHz	≤ 32kHz
transmitting element (pulsed)	white light LED	white light LED
display (signal)	5x yellow LED	5x yellow LED
setting	teach-in: button + input + software	teach-in: button + input + software
short-circuit protection	+	+
reverse polarity protection	+	+
pulse stretching	0 ... 100ms	0 ... 100ms
dimensions	65x65x42mm	65x65x42mm
housing material	aluminum, anodized	aluminum, anodized
operating temperature	-20 ... +55°C	-20 ... +55°C
degree of protection (EN 60529)	IP54	IP54
connection	PLC: 8-pin flange socket	PLC: 8-pin flange socket
connection accessories	2m PLC cable e.g. VK207B45	2m PLC cable e.g. VK207B45
interface	RS232	RS232
connection	PC: 5-pin flange socket	PC: 5-pin flange socket
connection accessories	2m PC cable, e.g. VK207U44	2m PC cable, e.g. VK207U44

connection

PLC connection cable

pin:	wire color	assignment:
1	white	GND (0V)
2	brown	12 ... 30V DC
3	green	input
4	yellow	switching output 0
5	gray	switching output 1
6	pink	switching output 2
7	blue	switching output 3
8	red	switching output 4

visualization

With the help of 5 yellow LEDs, the number of the detected color is displayed on the housing and simultaneously output as 5-bit binary information at digital outputs 0 to 4.

The Windows user interface simplifies the teach-in process on the sensor and supports the operator when making adjustments to and during the initial setup of the color sensor. Various evaluation processes can easily be selected for the color evaluation.

The color value is displayed in graphical form with the help of a color triangle as well as in the alphanumeric output fields.

The current raw data (red, green, blue) from the color detector are displayed in a bar graph.

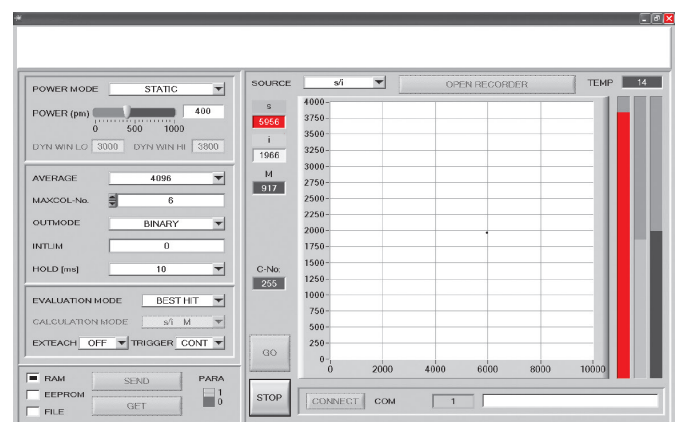

connection accessories

PLC connection cable

article no.	description
VK207B41	connection cable 2m, 8-pin, angular
VK207B45	connection cable 2m, 8-pin, straight
VK507B41	connection cable 5m, 8-pin, angular
VK507B45	connection cable 5m, 8-pin, straight
VKA07B45	connection cable 10m, 8-pin, straight
VKB07B41	connection cable 20m, 8-polig, angular
VKBE7B45	connection cable 25m, 8-polig, straight

connection accessories

PC connection cable

article no.	description
VK207U40	connection cable 2m, 5-pin, angular
VK207U44	connection cable 2m, 5-pin, straight
VK507U40	connection cable 5m, 5-pin, angular
VK507U44	connection cable 5m, 5-pin, straight

fiber optics versions

version fiber optics, dif. reflection sensor

article-no. LT060180

light beam (angle of beam spread) 22°

version fiber optics, dif. reflection sensor

article-no. LT060181

light beam (angle of beam spread) 67°

fiber optics, dif. reflection sensor

LT120181

67°

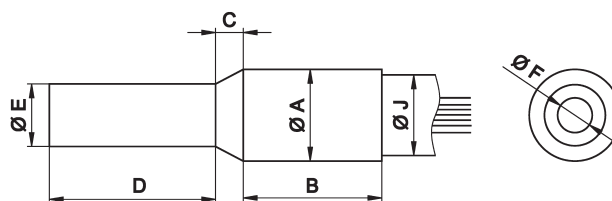

TECHNICAL DATA

standard lengths	600mm	1200mm
fiber bundle diameter F	1.5mm	1.5mm
material (outer jacket)	silicone-metal sheath	silicone-metal sheath
end sleeve	stainl. steel	stainl. steel
diameter A	6.6mm	6.6mm
dimension B	8mm	8mm
dimension C	2mm	2mm
dimension D	11mm	11mm
diameter E	2.5mm	2.5mm
diameter J	4.4mm	4.4mm
bending radius	4 x dimension J	4 x dimension J



version	fiber optics, dif. reflection sensor	fiber optics, dif. reflection sensor
article no.	LT060380	LT120380
light beam (angle of beam spread)	22°	22°
version	fiber optics, dif. reflection sensor	fiber optics, dif. reflection sensor
article no.	LT060381	LT120381
light beam (angle of beam spread)	67°	67°

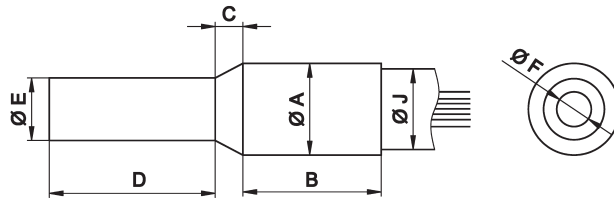

TECHNICAL DATA

standard lengths	600mm	1200mm
fiber bundle diameter F	2.5mm	2.5mm
material (outer jacket)	silicon metal sheath	silicon metal sheath
end sleeve	VA	VA
diameter A	6.6mm	6.6mm
dimension B	10mm	10mm
dimension C	2mm	2mm
dimension D	12mm	12mm
diameter E	4.5mm	4.5mm
diameter J	5.8mm	5.8mm
bending radius	4 x dimension J	4 x dimension J



version	fiber optics, through-beam sensors	fiber optics, through-beam sensors
article-no.	LS060380	LS120380
light beam (angle of beam spread)	22°	22°
version	fiber optics, through-beam sensors	fiber optics, through-beam sensors
article-no.	LS060381	LS120381
light beam (angle of beam spread)	67°	67°

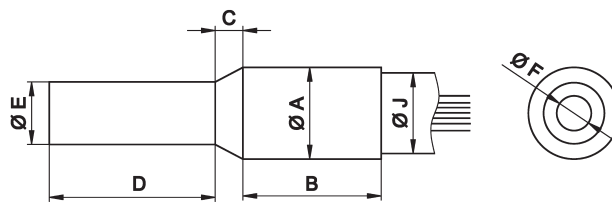

TECHNICAL DATA

standard lengths	600mm	1200mm
fiber bundle diameter F	2.5mm	2.5mm
material (outer jacket)	silicone-metal sheath	silicone-metal sheath
end sleeve	stainl. steel	stainl. steel
diameter A	6.6mm	6.6mm
dimension B	10mm	10mm
dimension C	2mm	2mm
dimension D	12mm	12mm
diameter E	4.5mm	4.5mm
diameter J	5.8mm	5.8mm
bending radius	4 x dimension J	4 x dimension J
* smallest detectable object		

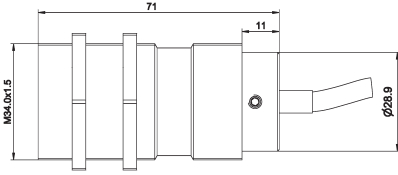
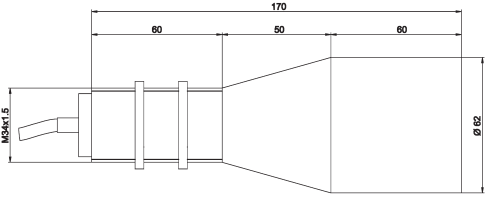

operating range	60 ... 120mm	20 ... 30mm
article no.	AL000039	AL000042
version	11mm spot	6mm spot
TECHNICAL DATA		
light spot size	11mm at 80mm distance	6mm at 25mm distance
operating range	60 ... 120mm	20 ... 30mm
material (housing)	aluminum	aluminum
material (optics)	glass, scratch resistant	glass, scratch resistant
comment	for fiber optic through-beam sensors	for fiber optic through-beam sensors
operating range	20 ... 65mm	
article no.	AL000045	
version	4.5mm spot	
TECHNICAL DATA		
light spot size	4,5mm bei 65mm Abstand	
operating range	20 ... 65mm	
material (housing)	aluminum	
material (optics)	glass, scratch resistant	
comment	for fiber optic through-beam sensors	

operating range	10 ... 250mm	80 ... 150mm
article no.	AL000046	AL000048
version	3mm spot	3mm spot
		
TECHNICAL DATA		
light spot size	19mm at 200mm distance	3mm at 120mm distance
operating range	100 ... 250mm	80 ... 150mm
material (housing)	aluminum	aluminum
material (optics)	glass, scratch resistant	glass, scratch resistant
comment	for fiber optic through-beam sensors	for fiber optic through-beam sensors