

dimensions	M8x0.5 10x37x25mm	
incremental	resolution	0.1mm

- ✓ **robust metal or plastic housing**
- ✓ **very easy installation of the complete measuring system**
- ✓ **high initial acceleration is possible**
- ✓ **resistant to wear maintaining high accuracy**
- ✓ **linear resolution 0.1mm after 4-time interpretation**



insensitive to dirt, humidity and vibration



description

Sensors for the detection of changes in position (linear) or angular change (rotating), which can detect the distance and direction of path and/or change of angle and direction of rotation are referred to as incremental encoders. The path measuring system consists of two parts: The sensing head and the magnetic tape. On the 10mm wide magnetic tape, north and south poles are alternating in a longitudinal direction with an exactly defined pole width. The magnetic tape is protected by a carrier strip on the rear and by a magnetically permeable masking tape made of stainless steel. A double-faced adhesive tape glued to the rear side is used as a fixture.

The sensing head mounted above the magnetic tape consecutively senses the different poles. From the sinusoidal signal which is generated, the integrated electronic system forms square wave signals.

These can be processed directly via a counter or a control. The sensor element has a width of 5mm and is located in the center of the sensing head. In environments with dust, chipping, moisture or mechanical impacts, a protective aluminum

section (**AM000050**) can be screwed above the magnetic tape (**AM000049**). The maximum tape length is 80m.

Using magnetic rings, a very robust, magnetically operating open encoder system is realized (e.g. with **AM000051**, max. 2048 pulses per revolution with fourfold evaluation!). Also simple angle position measurements can be realized.

The precision of the system, taking into account the magnetic tape length "L" in meters is $\pm(0.1 + 0.01 \times L)$ mm. The magnetic tape has to be 100mm longer than the required measured distance, 50mm need to be added on each side. For higher requirements, please use measuring system **MW11** (resolution 10µm, precision 50µm) with magnetic tape **AM000059**! Speeds up to 25m/s are permissible. A faster counter will then be needed for the evaluation, e.g. ipf type: **CI050100**.

application examples

- ▶ Linear measurement under toughest ambience conditions

article-no.	MW080100	MW100100	MW100400
operating voltage	24V DC	24V DC	24V DC
output current (max. load)	2 x 20mA	2 x 20mA	4 x 20mA
output signal	push pull A / B	push pull A / B	push pull A / A inverse, B / B inverse
article-no.	MW080105	MW100105	MW100405
operating voltage	5V DC	5V DC	5V DC
output current (max. load)	2 x 5mA	2 x 5mA	4 x 5mA
output signal	TTL A / B	TTL A / B	TTL A / A inverse, B / B inverse

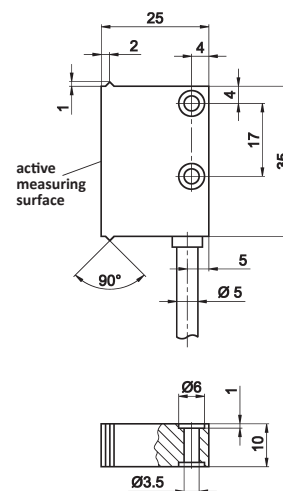
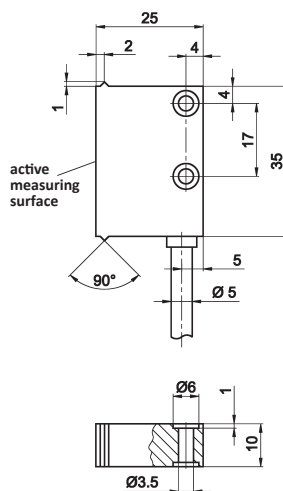
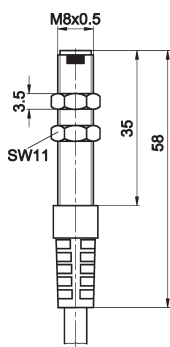

TECHNICAL DATA

sensing range	0.1 ... 2mm	0.1 ... 2mm	0.1 ... 2mm
output signal	see above	see above	see above
operating voltage	24V DC ± 20% / 5V DC ± 5%	24V DC ± 20% / 5V DC ± 5%	24V DC ± 20% / 5V DC ± 5%
current consumption (w/o load)	< 20mA	< 20mA	< 20mA
output current (max. load)	2x20mA / 2x5mA	2x20mA / 2x5mA	4x20mA / 4x5mA
accuracy *	±(0.1+0.01*L)mm	±(0.1+0.01*L)mm	±(0.1+0.01*L)mm
repeat accuracy	±1 increment	±1 increment	±1 increment
traversing speed	< 25m/s	< 25m/s	< 25m/s
vibration resistance	10g/50Hz	10g/50Hz	10g/50Hz
humidity	100%rh, condensation permitted	100%rh, condensation permitted	100%rh, condensation permitted
display (signal)	-	-	-
short-circuit protection	-	-	-
reverse polarity protection	+ (only at 24V DC)	+ (only at 24V DC)	+ (only at 24V DC)
housing material	stainless steel	plastic	plastic
dimensions	M8x0.5	10x37x25mm	10x37x25mm
length (thread / total)	35mm/58mm	-	-
operating temperature	-10 ... +70°C	-10 ... +70°C	-10 ... +70°C
system of protection (EN 60529)	IP67	IP67	IP67
connection	2m PUR cable, 4-wire	2m PUR cable, 4-wire	2m PUR cable, 6-wire
mounting accessories	2 nuts	2x M3x14 hexagon socket	2x M3x14 hexagon socket

* L = magnetic tape length in m
at +20° C

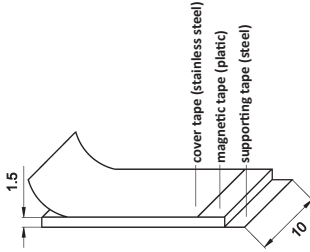
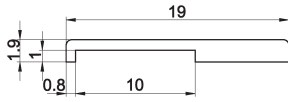
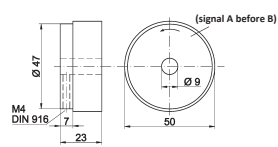
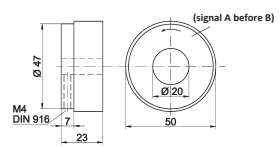
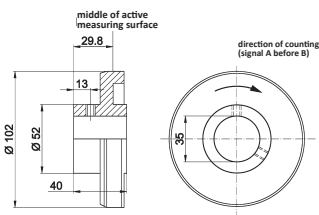
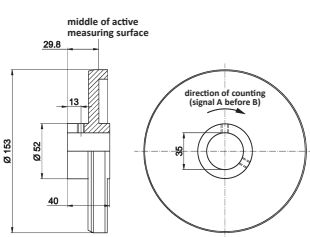
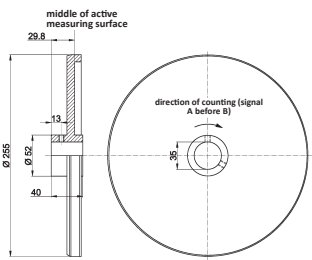
article-no.	AM000049	AM000050	
version	magnetic tape	profile rail	
magnetic pole length	3.2mm	-	
operating temperature	-20 ... +70°C	-	
humidity	100% rh, condensation permitted	-	
material	see drawing	aluminium	
mounting	glued joint	-	
			
article-no.	AM000051	AM000058	AM000055
version	magnetic ring	magnetic ring	magnetic ring
impulse per revolution	512	512	800
measuring range	360°	360°	360°
accuracy	±0.5°	±0.5°	±0.1°
operating temperature	0 ... +60°C	0 ... +60°C	-20 ... +70°C
humidity	100% rh, condensation permitted	100% rh, condensation permitted	100% rh, condensation permitted
material (flange)	aluminum	aluminum	aluminum
			
article-no.	AM000056	AM000057	
version	magnetic ring	magnetic ring	
impulse per revolution	1200	2000	
measuring range	360°	360°	
operating temperature	-20 ... +70°C	-20 ... +70°C	
humidity	100% rh, condensation permitted	100% rh, condensation permitted	
material (flange)	aluminum	aluminum	
			

connection

cable device 4-wire

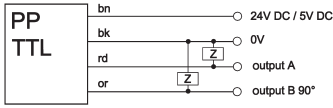

wire colors: bn = brown, bk = black, rd = red, or = orange, ye = yellow, gn = green

cable device 6-wire

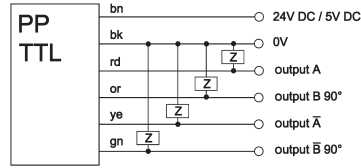

mounting notes

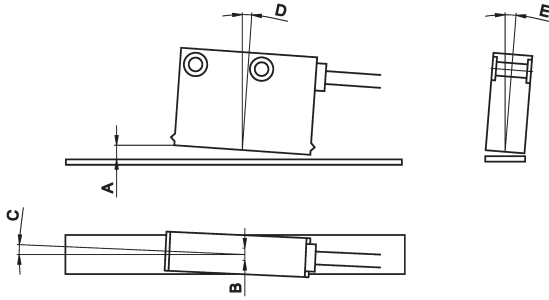

determination of the magnetic tape length

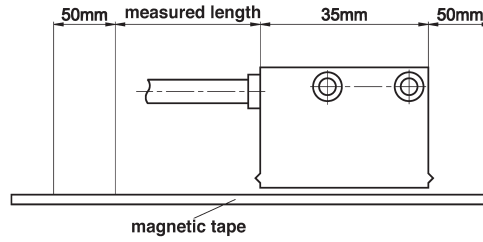

measured length + 35mm + (2*50mm) = magnetic tape length

MW10

sensing range	A	max. 2mm
lateral offset	B	max. ± 2mm
misalignment	C	< ±3°
longitudinal inclination	D	< ±1°
lateral inclination	E	< ±3°

traversing direction

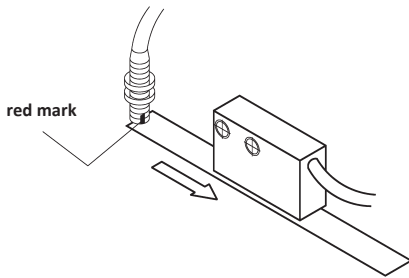

The arrow points to the direction of the linear measurement of the magnetic tape and/or the direction of rotation of the magnetic ring (signal A before B). Please observe the red marking when positioning the sensors for **MW08**! An indication for positioning the **MW10** is the cable outlet.

rotational direction

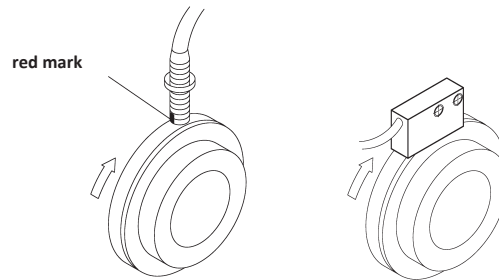

signal pictures

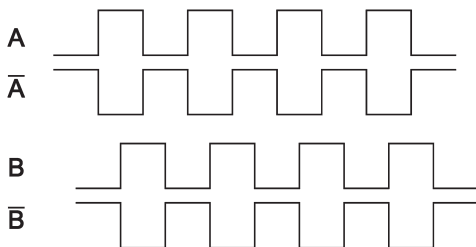

This data sheet contains the available standard versions only. Kindly request the availability of other output- and connection functions.

Warning: Never use these devices in applications where the safety of a person depends on their functionality.

You also find this data sheet, as well as contact details under www.ipf-electronic.com