

dimensions **10x37x25mm**
 incremental resolution **0.25mm**

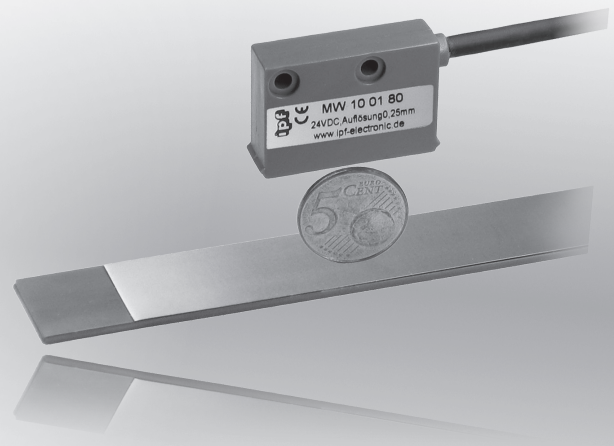

- ✓ insensitive to dirt, humidity and vibration
- ✓ robust metal or plastic housing
- ✓ very easy installation of the complete measuring system
- ✓ high initial acceleration is possible
- ✓ resistant to wear maintaining high accuracy
- ✓ linear resolution 0.25mm after 4-time interpretation

distance sensor / band: 5 ... 20mm
lateral offset ±5mm



description

Sensors for the detection of changes in position (linear) or angular change (rotating), which can detect the distance and direction of path and/or change of angle and direction of rotation are referred to as **incremental encoders**. The path measuring system consists of two parts: The sensing head and the magnetic tape. On the 10mm (20mm) wide magnetic tape, north and south poles are alternating in a longitudinal direction with an exactly defined pole width. The magnetic tape is protected by a carrier strip on the rear and by a magnetically permeable masking tape made of stainless steel. A double-faced adhesive tape glued to the rear side is used as a fixture. The sensing head mounted above the magnetic tape consecutively senses the different poles. From the sinusoidal signal which is generated, the integrated electronic system forms square wave signals. These can be processed directly via a counter or a control. The sensor element has a width of 5mm and is located in the

center of the sensing head. In environments with dust, chipping, humidity or mechanical impacts, a protective aluminum section (**AM000050**) can be screwed above the magnetic tape (**AM000085**). For 20 mm wide magnetic tape **AM000109** stands the porofil rail **AM000117** available. The maximum tape length is 80m.

The precision of the system, taking into account the magnetic tape length "L" in meters is $\pm(1 + 0.03 \times L)$ mm. The magnetic tape has to be 100mm longer than the required measured distance, 50mm need to be added on each side. For higher requirements, please use measuring system **MW11** (resolution 10µm, precision 50µm) with magnetic tape **AM000059**!

application examples

- ▶ Linear measurement under toughest ambience conditions

article-no.	MW100150	MW100180
operating voltage	24V DC	24V DC
output current (max. load)	2 x 20mA	2 x 20mA
output signal	A,B / push pull	A, B / push pull

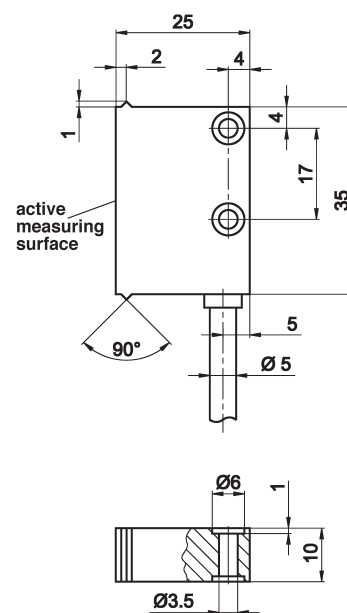
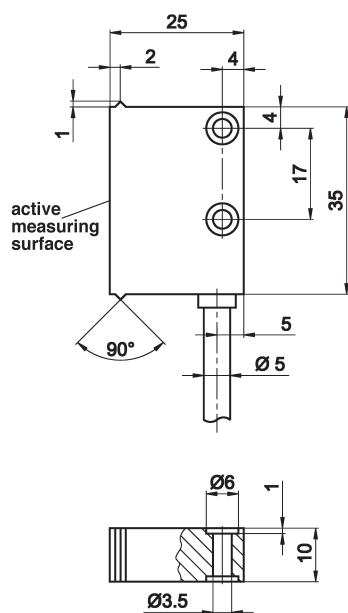

TECHNICAL DATA

sensing range	10mm	5 ... 20mm
output signal	A,B / push pull	A,B / push pull
operating voltage	24V DC \pm 20%	24V DC \pm 20%
current consumption (w/o load)	< 50mA	< 50mA
output current (max. load)	2x20mA	2x20mA
voltage drop (max. load)	\leq 1.5V DC	\leq 1.5V DC
accuracy *	$\pm(1+0.03*L)$ mm	$\pm(1+0.03*L)$ mm
repeat accuracy	max. \pm 0.25mm	max. \pm 0.5mm
traversing speed	< 10m/s	< 15m/s
vibration resistance	10g/50Hz	10g/50Hz
humidity	100%rh, condensation permitted	100%rh, condensation permitted
display (signal)	-	-
short-circuit protection	+	+
reverse polarity protection	+	+
housing material	plastic	plastic
dimensions	10x37x25mm	10x37x25mm
operating temperature	-10 ... +70°C	-10 ... +70°C
system of protection (EN 60529)	IP67	IP67
connection	2m PUR cable, 4-wire	2m PUR cable, 4-wire
mounting accessories	2x M3x14mm hexagon socket	2x M3x14mm hexagon socket
accessories	AM000085	AM000109

* L = magnetic tape length in m
at +20° C

article-no.	AM000085	AM000050
version	magnetic tape	profile rail
pole length	20mm	-
operating temperature	-20 ... +70°C	-
humidity	100% rh, condensation permitted	-
material	see drawing	aluminum
mounting	glued joint	-
article-no.	AM000109	AM000117
version	magnetic tape	profile rail
pole length	40mm	-
operating temperature	-20 ... +70°C	-
humidity	100% rh, condensation permitted	-
material	see drawing	aluminum
mounting	glued joint	-

connection

cable device

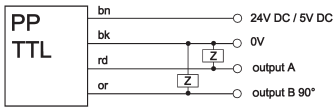

wire colors: bn = brown, bk = black, rd = red, or = orange

mounting notes

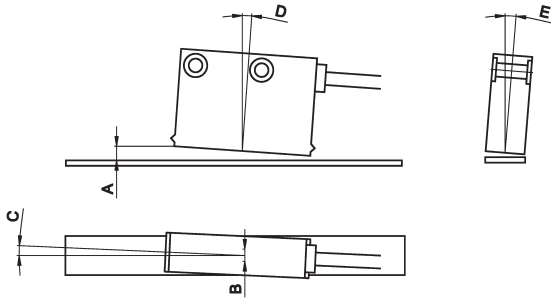

determination of the magnetic tape length

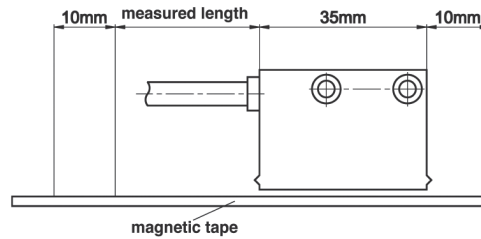

measured length + 35mm + (2*50mm) = magnetic tape length

MW100150

sensing range	A	max. 10mm
lateral offset	B	max. ± 2mm
misalignment	C	< ±3°
longitudinal inclination	D	< ±3°
lateral inclination	E	< ±3°

MW100180

sensing range	A	5 ...20mm
lateral offset	B	max. ± 5mm
misalignment	C	< ±10°
longitudinal inclination	D	< ±3°
lateral inclination	E	< ±3°

traversing direction

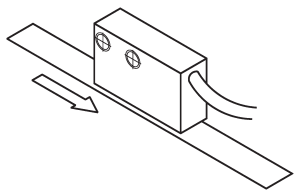

The arrow points to the direction of the linear measurement of the magnetic tape (signal A before B). An indication for positioning the **MW10** is the cable outlet.

signal pictures

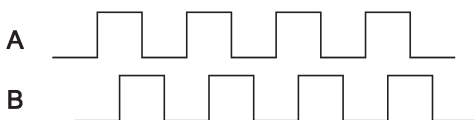

This data sheet contains the available standard versions only. Kindly request the availability of other output- and connection functions.

Warning: Never use these devices in applications where the safety of a person depends on their functionality.

You also find this data sheet, as well as contact details under www.ipf-electronic.com