

dimensions	10x37x25mm	
incremental	resolution	10µm

- ✓ distance sensor / band: max. 2mm
- ✓ robust plastic housing
- ✓ very easy installation of the complete measuring system
- ✓ high initial acceleration is possible
- ✓ resistant to wear maintaining high accuracy
- ✓ linear resolution 10µm after 4-time interpretation

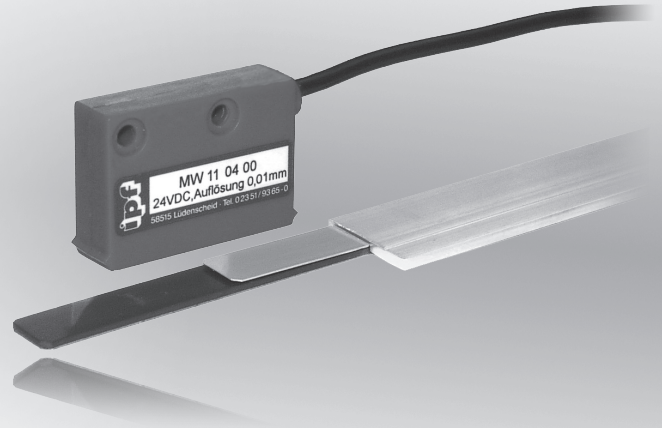

insensitive to dirt, humidity and vibration



description

Sensors for the detection of changes in position (linear) or angular change (rotating), which can detect the distance and direction of path and/or change of angle and direction of rotation are referred to as incremental encoders. The path measuring system consists of two parts: The sensing head and the magnetic tape. On the 10mm wide magnetic tape, north and south poles are alternating in a longitudinal direction with an exactly defined pole width. The magnetic tape is protected by a carrier strip on the rear and by a magnetically permeable masking tape made of stainless steel. A double-faced adhesive tape glued to the rear side is used as a fixture.

The sensing head mounted above the magnetic tape consecutively senses the different poles. From the sinusoidal signal which is generated, the integrated electronic system forms square wave signals.

These can be processed directly via a counter or a control.

The sensor element has a width of 5mm and is located in the center of the sensing head. In environments with dust, chipping, moisture or mechanical impacts, a protective aluminum section (**AM000050**) can be screwed above the magnetic tape (**AM000059**). The maximum tape length is 80m.

The precision of the system, taking into account the magnetic tape length "L" in meters is $\pm(0.025 + 0.01 \times L)$ mm. The magnetic tape has to be 55mm longer than the required measured distance.

For the further evaluation please connect the multifunction counter **CI050100**.

application examples

- ▶ Linear measurement under toughest ambience conditions

article-no.	MW110400	MW110405	MW110410	MW110411
operating voltage	24V DC	5V DC	24V DC	24V DC
output current (max. load)	4 x 20mA	4 x 5mA	6 x 20mA	6 x 20mA
output signal	push pull A / A inverse B / B inverse	line driver A / A inverse B / B inverse	push pull A / A inverse B / B inverse I / I inverse	push pull A / A inverse B / B inverse I / I inverse
pulse distance	1µs	1µs	1µs	1µs
TECHNICAL DATA				
sensing range	0.4 ... 2.0mm	0.4 ... 2.0mm	0.4 ... 2.0mm	0.4 ... 2.0mm
output signal	push pull A/A inverse, B/B inverse	line driver A/A inverse, B/B inverse	push pull A/A inverse, B/B inverse I / I inverse	push pull A/A inverse, B/B inverse I / I inverse
resolution	0.01mm	0.01mm	0.01mm	0.01mm
pulse distance	1µs	1µs	1µs	1µs
operating voltage	24V DC ±20%	5V DC ±5%	24V DC ±20%	24V DC ±20%
current consumption (w/o load)	< 70mA	< 70mA	< 70mA	< 70mA
output current (max. load)	4x20mA	4x5mA	6x20mA	6x20mA
accuracy *	±(0.025+0.01*L)mm	±(0.025+0.01*L)mm	±(0.025+0.01*L)mm	±(0.025+0.01*L)mm
repeat accuracy	± 1 increment	± 1 increment	± 1 increment	± 1 increment
traversing speed	< 6.9m/s	< 6.9m/s	< 6.9m/s	< 6.9m/s
vibration resistance	10g/50Hz	10g/50Hz	10g/50Hz	10g/50Hz
humidity	100% rh condensation permitted	100% rh condensation permitted	100% rh condensation permitted	100% rh condensation permitted
display (signal)	-	-	-	-
short-circuit protection	+	+	+	+
reverse polarity protection	+	+	+	+
housing material	plastic	plastic	plastic	plastic
dimensions	10x37x25mm	10x37x25mm	10x37x25mm	10x37x25mm
operating temperature	-10 ... +70°C	-10 ... +70°C	-10 ... +70°C	-10 ... +70°C
system of protection (EN 60529)	IP67	IP67	IP67	IP67
connection	2m PUR cable, 6-wire	2m PUR cable, 6-wire	2m PUR cable, 8-wire	5m PUR cable, 8-wire
mounting accessories	2x M3x14mm hexagon socket	2x M3x14mm hexagon socket	2x M3x14mm hexagon socket	2x M3x14mm hexagon socket
* L = magnetic tape length in m at +20° C				

article-no.	MW110430	MW110431	MW110435
operating voltage	24V DC	24V DC	5V DC
output current (max. load)	4 x 20mA	4 x 20mA	4 x 5mA
output signal	push pull A / A inverse B / B inverse	push pull A / A inverse B / B inverse	line driver A / A inverse B / B inverse
pulse distance	4µs	4µs	4µs
TECHNICAL DATA			
sensing range	0.4 ... 2.0mm	0.4 ... 2.0mm	0.4 ... 2.0mm
output signal	push pull A/A inverse, B/B inverse	push pull A/A inverse, B/B inverse	line driver A/A inverse, B/B inverse
resolution	0.01mm	0.01mm	0.01mm
pulse distance	4µs	4µs	4µs
operating voltage	24V DC ±20%	24V DC ±20%	5V DC ±5%
current consumption (w/o load)	< 70mA	< 70mA	< 70mA
output current (max. load)	4x20mA	4x20mA	4x5mA
accuracy *	±(0.025+0.01*L)mm	±(0.025+0.01*L)mm	±(0.025+0.01*L)mm
repeat accuracy	± 1 increment	± 1 increment	± 1 increment
traversing speed	< 1.7m/s	< 1.7m/s	< 1.7m/s
vibration resistance	10g/50Hz	10g/50Hz	10g/50Hz
humidity	100% rh condensation permitted	100% rh condensation permitted	100% rh condensation permitted
display (signal)	-	-	-
short-circuit protection	+	+	+
reverse polarity protection	+	+	+
housing material	plastic	plastic	plastic
dimensions	10x37x25mm	10x37x25mm	10x37x25mm
operating temperature	-10 ... +70°C	-10 ... +70°C	-10 ... +70°C
system of protection (EN 60529)	IP67	IP67	IP67
connection	2 m PUR-Kabel, 6-wire	5m PUR cable, 6-wire	2m PUR cable, 6-wire
mounting accessories	2x M3x14mm hexagon socket	2x M3x14mm hexagon socket	2x M3x14mm hexagon socket
* L = magnetic tape length in m at +20° C			

article-no.	AM000059	AM000050
version	magnetic tape	profile rail
pole length	5mm	-
operating temperature	-20 ... +70°C	-
humidity	100% rh, condensation permitted	-
material	see drawing	aluminum
mounting	glued joint	screw connection

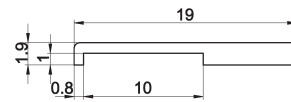
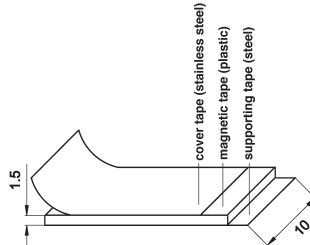

connection

cable device 6-wire

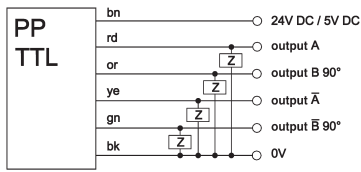

cable device 8-wire

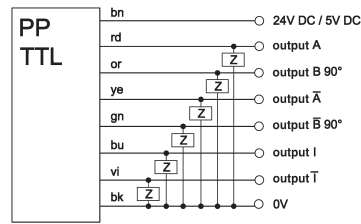

wire colors: bn = brown, rd = red, or = orange, ye = yellow, gn = green, bu = blue, vi = violet, bk = black

mounting notes

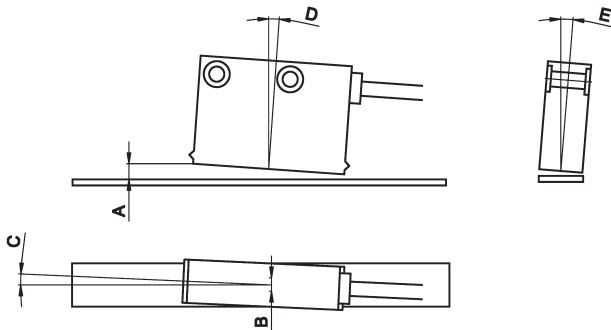

determination of the magnetic tape length

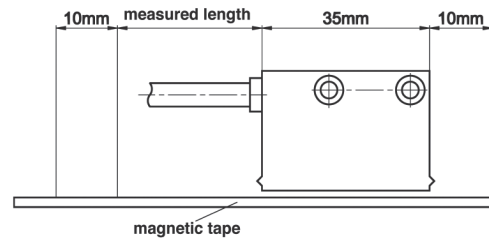

Messweg + 35mm + (2*10mm) = Magnetbandlänge

MW100150

sensing range	A	max. 2.0mm
lateral offset	B	max. ± 2.0mm
misalignment	C	< ±3°
longitudinal inclination	D	< ±1°
lateral inclination	E	< ±3°

traversing direction

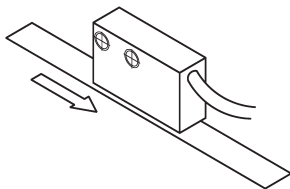

The arrow points to the direction of the linear measurement of the magnetic tape (signal A before B). An indication for positioning the MW11 is the cable outlet.

signal pictures

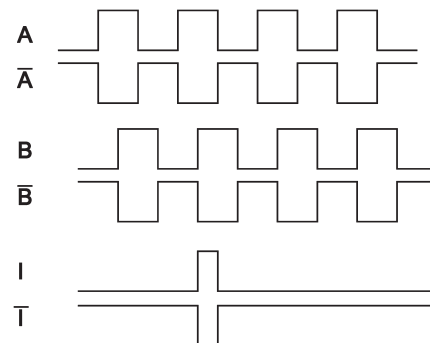

This data sheet contains the available standard versions only. Kindly request the availability of other output- and connection functions.

Warning: Never use these devices in applications where the safety of a person depends on their functionality.

You also find this data sheet, as well as contact details under www.ipf-electronic.com

NOTES

