

design	30 x 90.4 x 25.5mm 30 x 136.4 x 25.5mm 30 x 159.4 x 25.5mm	
logic module	1 x 4-way 2 x 2-way 1 x 8-way 2 x 4-way 1 x 10-way 2 x 5-way	AND / OR AND respectively OR AND / OR AND respectively OR AND / OR
AND		

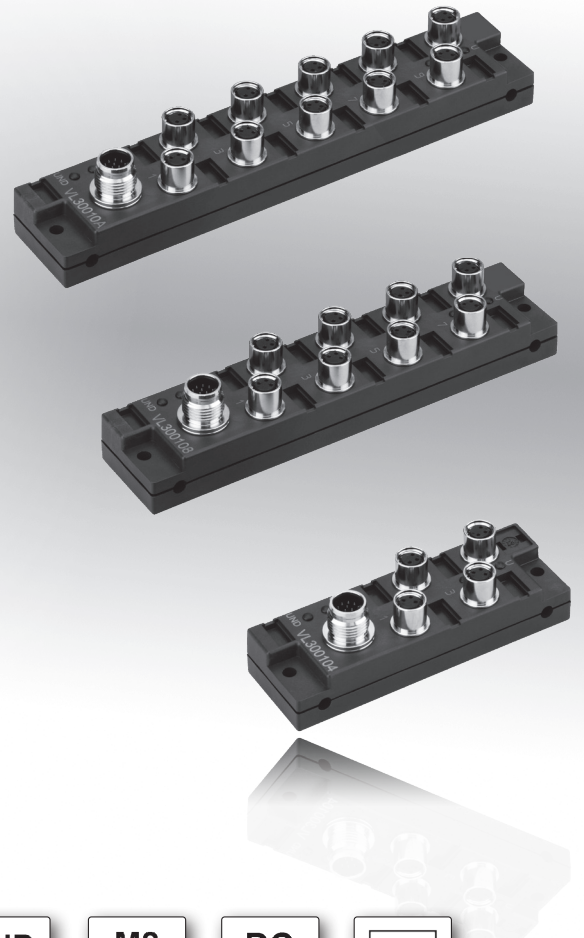

- ✓ flat robust design
- ✓ 12-pin M12-connector for the connection line to the control unit
- ✓ 3-pin assignment of the M8-sockets for inputs
- ✓ LED status displays
- ✓ system of protection IP67
- ✓ simple vibration-proof connection of sensor leads

AND / OR logic operation on location minimized amount of cabling



description

It is often the case, that the signals of many sensors are linked in an application in order to provide a statement about an operational state.

If this linkage is adopted in the control unit, it is necessary to run the signals of each sensor up until there via leads, and process them in the control program.

In many cases, it would be sufficient to link the sensor signals to one another on-site and only transmit one linked end-signal to the control unit.

ipf electronic logic distribution terminals are used for this purpose. According to the module, up to 10 sensors can be connected and logically linked to one another. AND and/or OR versions are available as logical variants.

The user can directly see which signals are pending and/or

which are missing (as the case may be) by means of LED status display of the logic modules. The status of the linked end signals is similarly shown via output LEDs. All versions have two separated signal outputs. In the 2 x 2-way / 2 x 5-way types, the input signals of the right and left module halves are linked independent from each other.

In the other logic modules, one output issues the result of the AND link and the other issues the result of the OR link.

If, in the case of an AND module, an input slot cannot be taken up by a sensor, a so-called "jumper" plug can be supplied.

application examples

- ▶ signal linkage of multiple sensors

article-no.	VL300104	VL300108
output	AND- / OR-linked, 4-way	AND- / OR-linked, 8-way
article-no.	VL300114	VL300118
output	AND-linked, 2 x 2-way	AND-linked, 2 x 4-way
article-no.	VL300134	VL300138
output	OR-linked, 2 x 2-way	OR-linked, 2 x 4-way

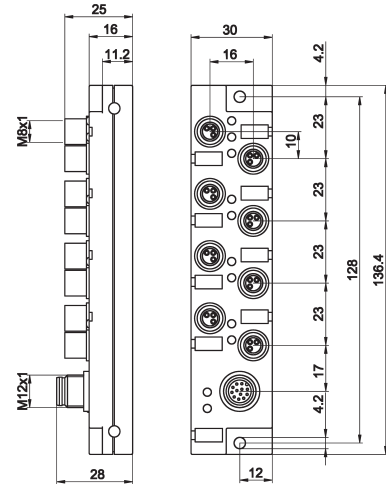
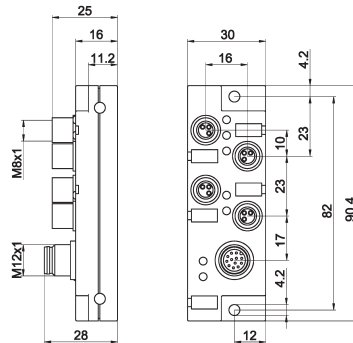

TECHNICAL DATA

input	pnp, no (signal on pin 4)	pnp, no (signal on pin 4)
output (linked)	see above	see above
operating voltage	10 ... 30V DC	10 ... 30V DC
current consumption (max. load)	1A	1A
output current (max. load)	200mA per output	200mA per output
insulation resistance	> 10 ⁹ Ω	> 10 ⁹ Ω
display (function)	operating voltage: 1 x green LED	operating voltage: 1 x green LED
display (signal)	1 x yellow LED per slot	1 x yellow LED per slot
housing material	plastic (PBT)	plastic (PBT)
contact material	CuZn, pre-nickled and gold-plated plug-in and pull-out power ≥ 0.5N	CuZn, pre-nickled and gold-plated plug-in and pull-out power ≥ 0.5N
design	30x90.4x25.5mm	30x125.4x25.5mm
operating temperature	-25 ... +70°C	-25 ... +70°C
plug-in cycles	≤ 50	≤ 50
degree of soiling	3	3
inflammability class	UL 94 V-0	UL 94 V-0
system of protection (EN 60529)	IP67 - only when screwed to the corresponding matching parts or plank plugs	IP67 - only when screwed to the corresponding matching parts or plank plugs
connection	module: M12-connector, 12-pin	module: M12-connector, 12-pin
connection accessories	cable socket e.g. VK200C25 , 2m, PUR, straight	cable socket e.g. VK200C25 , 2m, PUR, straight
connection	sensors: 4 x M8-socket, 3-pin	sensors: 8 x M8-socket, 3-pin
connection accessories	connection cable, e.g. VK200F74 , 2m, PUR, straight	connection cable, e.g. VK200F74 , 2m, PUR, straight

article-no.	VL30010A
output	AND- / OR-linked, 10-way
article-no.	VL30011A
output	AND-linked, 2 x 5-way

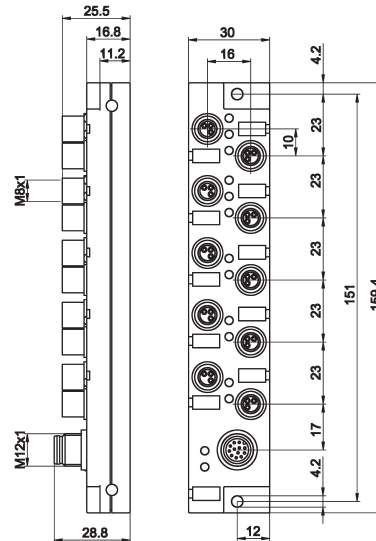

TECHNICAL DATA

input	pnp, no (signal on pin 4)
output (linked)	see above
operating voltage	10 ... 30V DC
current consumption (max. load)	1A
output current (max. load)	200mA per output
insulation resistance	> 10 ⁹ Ω
display (function)	operating voltage: 1 x green LED
display (signal)	1 x yellow LED per slot
housing material	plastic (PBT)
contact material	CuZn, pre-nickled and gold-plated plug-in and pull-out power ≥ 0.5N
design	30x90.4x25.5mm
operating temperature	-25 ... +70°C
plug-in cycles	≤ 50
degree of soiling	3
flammability class	UL 94 V-0
system of protection (EN 60529)	IP67 - only when screwed to the corresponding matching parts or plank plugs
connection	module: M12-connector, 12-pin
connection accessories	cable socket e.g. VK200C25 , 2m, PUR, straight
connection	sensors: 10 x M8-socket, 3-pin
connection accessories	connection cable, e.g. VK200F74 , 2m, PUR, straight

connection

M12-connector pin assignment	4-way logic module	8-way logic module
1 (brown)	+ 24V DC	+ 24V DC
2 (blue)	0V DC	0V DC
3 (white)	E1	output 1
4 (green)	E2	output 2
5 (pink)	E3	-
6 (yellow)	E4	-
7 (black)	output 1	output 1
8 (gray)	output 2	output 2
9 (red)	-	-
10 (purple)	-	-
11 (grey/pink)	-	-
12 (red/blue)	-	-

wire colors of the cable socket (module) in brackets

wiring diagrams

VL300104 4-way

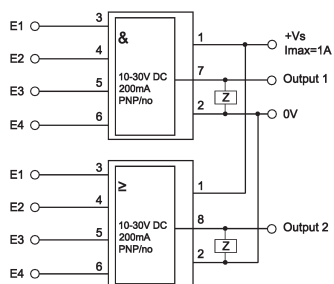

VL300114 2 x 2-way

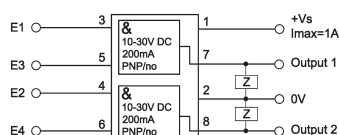

VL300134 2 x 2-way

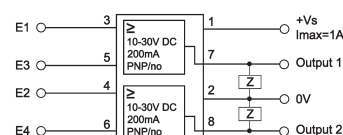

VL300108 8-way

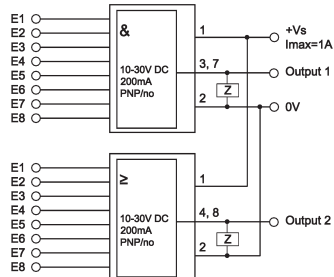

VL300118 2 x 4-way

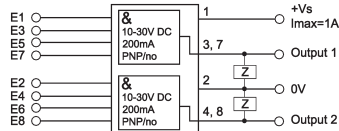

VL300138 2 x 4-way

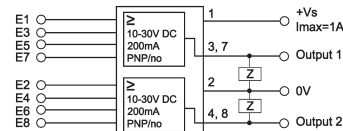

VL30010A 10-way

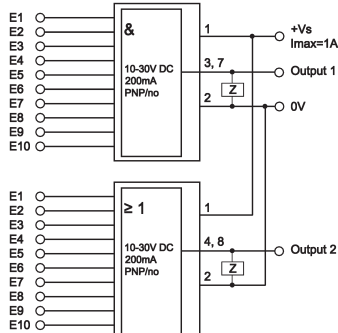

VL30011A 2 x 5-way

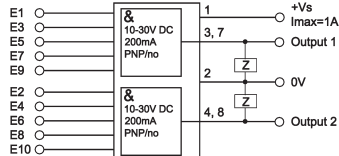

E1 to E10 are the inputs of the connected sensors (connections of the M8-connectors)
1 to 10 are the pin configurations of the module (connection for the M12-cable socket)

ACCESSORIES

article-no.	description	material
VK000034	blank plug M8, 2x included in the scope of delivery	plastic
VK000042	jumper simulation „switching output on“	

Warning: Never use these devices in applications where the safety of a person depends on their functionality!