

# **WHITEPAPER**

## INDUCTIVE SENSORS

Author: Dipl.-Ing. Christian Fiebach  
Executive Manager ipf electronic gmbh

Dipl.-Ing. Volker Grefe  
Head of PM/PR Division  
ipf electronic gmbh

**IPF** ELECTRONIC

# TABLE OF CONTENTS

1 Introduction .....	3
2 Classification of inductive sensors.....	3
3 Wide selection .....	3
4 Functionality of an inductive proximity switch .....	3
4.1 Switching distances, norm measuring plate and switching hysteresis .....	4
4.2 Output circuit.....	5
4.3 Output function .....	5
4.4 Series connection and parallel connection .....	5
5 Mounting .....	6
6 Correction factors .....	9
7 Switching frequency .....	9
8 Cable routing .....	9
8.1 Electrical connection .....	10
8.2 Tightening torques .....	10
8.3 Active switching zone / active surface .....	10
8.4 Repeat accuracy .....	10
8.5 Reverse polarity and short-circuit protection (DC devices) .....	10
9 Overview of inductive sensors .....	11
9.1 Up to 3-fold norm switching distance .....	11
9.2 Up to 4-fold norm switching distance .....	11
9.3 With metallic sensor surface / full metal housing .....	12
9.4 Acid and alkaline-resistant.....	12
9.5 For extended operating temperature range up to +180°C .....	13
9.6 Two-piece systems up to +230°C .....	13
9.7 Welding-resistant versions .....	14
9.8 Distance-measuring sensors .....	14
9.9 High-pressure resistant devices for hydraulic cylinders .....	15
9.10 Ring-shaped versions .....	16
9.11 Hose mounting .....	16

### 1 INTRODUCTION

Inductive sensors are contactless and wear-free components. Moreover, they have a high switching frequency and switching accuracy. Such devices are therefore ideal for the contactless detection of all conductive metals, regardless of whether they are moving or not.

### 2 CLASSIFICATION OF INDUCTIVE SENSORS

Inductive sensors are divided into flush-mountable, semi-flush-mountable and non-flush-mountable devices. If an inductive proximity switch is installed in a metal backing material, the installation parameters for flush, semi-flush or non-flush initiators must be observed in order to avoid undefined switching of the device.

### 3 WIDE SELECTION

There is an extremely wide selection of inductive sensors. Devices are available with norm switching distance, extended switching distance, up to threefold norm switching distance and up to fourfold norm switching distance. As sensors with threefold or fourfold norm switching distance have a high sensitivity, they are subject to special installation guidelines.

There are also inductive sensors with full-metal housings (including active surfaces made of metal), devices with an extended operating temperature range  $>110^{\circ}\text{C}$ , sensors for special environmental conditions, welding-resistant (magnetic-field resistant) sensors, distance-measuring sensors, high-pressure resistant sensors for hydraulic cylinders, ring-shaped sensors as well as devices for hose mounting.

### 4 FUNCTIONALITY OF AN INDUCTIVE PROXIMITY SWITCH

In simple terms, inductive proximity switches consist of a coil (oscillator) immediately behind the sensor head (active surface of the proximity switch), followed by the evaluation electronics and output stage or amplifier. The oscillating circuit oscillator generates a high-frequency magnetic field and the oscillating coil an alternating electromagnetic field; these fields are emitted at the active surface. Any electrically conductive material (damping object) approaching the field will induce eddy currents, extracting energy from the oscillator. The damping of the oscillator is then converted into a switching signal in the amplifier.

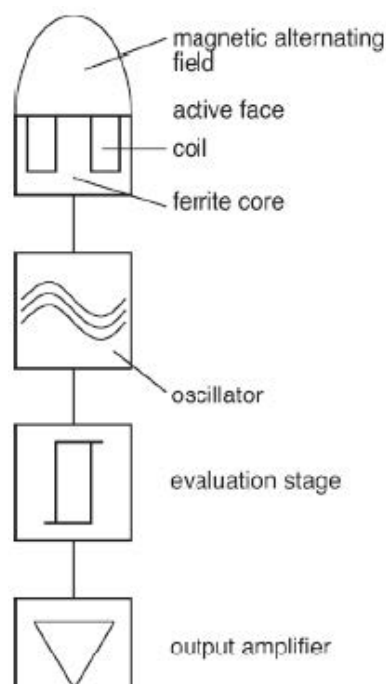

(all pictures: ipf electronic gmbh)

#### **4.1 SWITCHING DISTANCES, NORM MEASURING PLATE AND SWITCHING HYSTERESIS**

The distance to the sensor surface, where a metal causes a change in the switching state, is called switching distance. This distance is not the same for all metals. Therefore, a so-called correction factor has been specified for the respective metal, e.g. copper or aluminum. The largest switching distances can be achieved using ferromagnetic materials such as steel or iron. With other metals, however, the range can be smaller depending on the sensor type.

Unlike the switching distance, the nominal switching distance is determined using a norm measuring plate.

A distinction is made between the rated switching distance or nominal switching distance  $S_n$ , the real switching distance  $S_r$ , the usable switching distance  $S_u$  and the operating switching distance  $S_a$ . The nominal switching distance is the distance at which the norm measuring plate, which approaches the active surface of the sensor, causes a status change of the switching output. The nominal switching distance as parameter is determined without taking scattering (tolerance around the nominal value) and external factors into consideration. The real switching distance  $S_r$  is measured at a single proximity switch under specific conditions and is  $[0.9 S_n] \leq S_r \leq [1.1 S_n]$ . In addition to the tolerances of the real switching distance, the usable switching distance  $S_u$  takes into consideration the permissible tolerances for temperature and voltage fluctuations ( $[0.81 S_n] \leq S_u \leq [1.21 S_n]$ ). The operating switching distance is the range which represents the reliable switching distance under practical conditions, taking all tolerances into consideration. This switching distance is between 0 and 81 percent of  $S_n$  ( $0 < S_a < [0.81 \times S_n]$ ).

In line with DIN 18800, the 1mm thick norm measuring plate is made of S235, i.e. structural steel with a minimum yield strength of 235N/mm<sup>2</sup> (previously ST37 to achieve the minimum tensile strength of 370N/mm<sup>2</sup>). The norm measuring plate is square-shaped, whereby the edge length corresponds to the diameter of the active surface. A larger norm measuring plate is used for devices with extended switching distance (3-fold or 4-fold norm switching distance).

General rule: The larger the active surface, the larger the possible switching distance. However, it must be noted that the possible switching distance will be less if the material surface is considerably smaller compared to the active sensor surface (influence of geometry).

In this context, the switching hysteresis describes the distance differential between the switch-on point for an object which is approaching the sensor head, and the switch-off point when the object moves away from the sensor again, whereby the switch-on point is closer to the sensor than the switch-off point. This built-in hysteresis prevents the switching output from tilting back and forth in the case of mechanical vibrations and usually ranges between 5 and 15 percent of  $S_n$ .

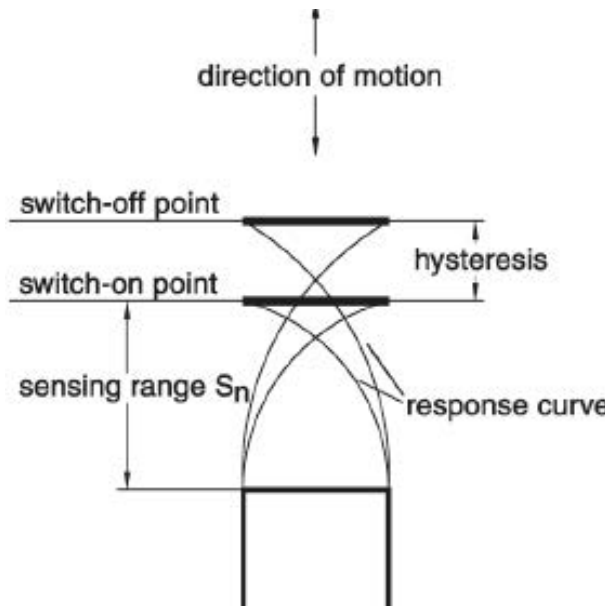

**4.2 OUTPUT CIRCUIT**

For the switching outputs of DC devices, a differentiation is made between **PNP** and **NPN**. For **PNP** outputs the load is connected in such a way that it is energized (positive switching) when the sensor is driven to full output (damping). **NPN** devices maintain their load permanently energized, switching the earth connection only (negative switching)..

The alternating current devices are usually 2-wire devices without short-circuit protection. Consequently a load must be connected, which allows for a minimum load current of 2mA or 5mA, however, not exceeding the maximum load current.

Proximity switches with analog output circuits are used in the control and measurement industry. Instead of a switching signal, these devices produce either a linear voltage (0 to 10V) or a current (4 to 20mA) as an analog signal which is proportional to distance.

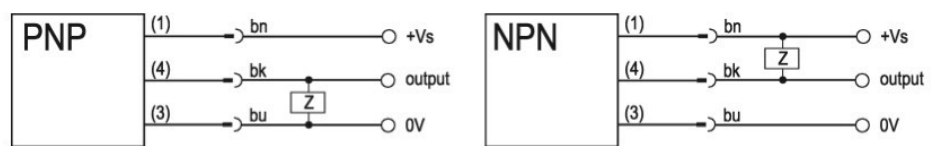

**4.3 OUTPUT FUNCTION**

Normally open (no): Object within the area of the active switching zone – output switched.  
 Normally closed (nc): Object within the area of the active switching zone – output inhibited.

**4.4 SERIES CONNECTION AND PARALLEL CONNECTION**

To be operationally safe the connection in series of 3-wire PNP sensors requires a logical AND-gate, e.g. the **VL250100**.

When connecting 3-wire PNP-sensors in parallel, the internal resistance of the sensor that is driven to full output influences the other proximity switches. This requires decoupling diodes to be inserted into the out-puts. A logic OR-gate, e.g. the **VL250120**, can be used to facilitate the parallel connection.

### 5 MOUNTING

If an inductive proximity switch is installed in a metal backing material, the installation parameters for flush, semi-flush or non-flush initiators must be observed in order to avoid undefined switching of the device.

With flush-mountable devices, the active surface of the sensor head may be level with the backing material (metal), whereby the specified distances must be observed

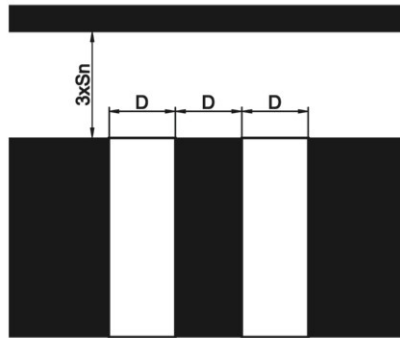

$S_n$  stands for the nominal switching distance (see page 5): the distance at which the norm measuring plate, which approaches the active surface of the sensor, causes a status change of the switching out-put.

With semi-flush-mountable sensors, the active surface of the device must protrude by dimension  $X$  from the metallic installation surface. The distances specified in the respective data sheet must also be observed here.

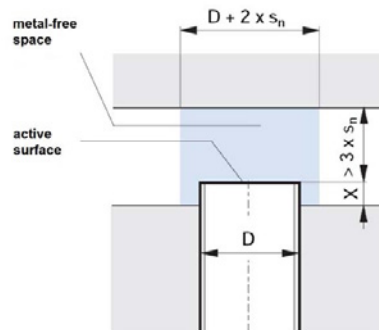

For non-flush mounting the active surface must not be surrounded by the metal of the carrier. The active surface of the device must therefore protrude from a metallic mounting surface in compliance with the specified distances. Through this the electromagnetic field is less damped, thus allowing larger switching distances.

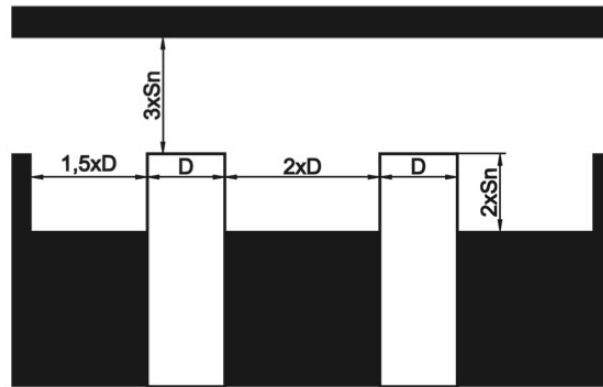

The type-specific response curves apply for offset or lateral movements. The response curves have a different shape depending on the series, size and installation type (flush, semi-flush, non-flush).

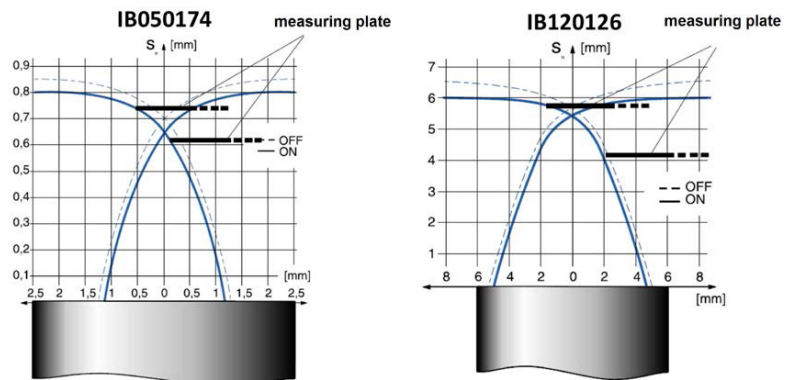

The response curves have a different shape depending on the series, size and installation type of the sensors.

By way of an example, the following graphics show an overview of the effect of material and geometry on switching distance, whereby this data may differ depending on the respective device series:

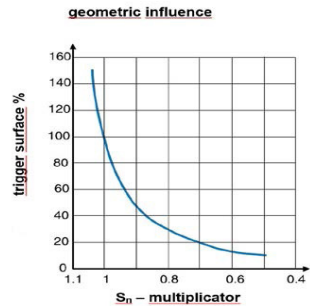

*impact of materials (guide values):*

material of the measuring plate	switching distance
steel typ FE 360	$S_n \times 1.00$
aluminum	$S_n \times 0.36 / *0.28$
brass	$S_n \times 0.44 / *0.37$
copper	$S_n \times 0.32 / *0.24$
stainless steel V2A	$S_n \times 0.69$

The previous designations for steel type FE 360 / ST37 correspond to the designation S235 used today.

The specified switching distance of inductive proximity switches is based on precisely defined measuring conditions. The use of other layouts or materials normally results in reduced switching distances.

The specified data should therefore be regarded as guide values. For example, an increase in switching distance should be expected for thin foils.

An exception is the so-called PRO series which has a full stainless steel housing (including the active surface) and switching distances up to threefold norm switching distance.

With this sensor series, changes in material have only a slight impact on the switching distance. For example, a reduction in the switching distance is to be expected in the case of foils

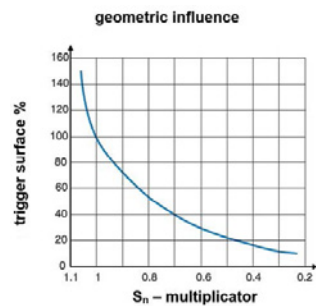

*impact of materials (guide values):*

material of the measuring plate	switching distance
steel typ FE 360	$S_n \times 1.0$
aluminum	$S_n \times 1.0$
brass	$S_n \times 1.3$
copper	$S_n \times 0.8$
stainless steel (thickness 1mm)	$S_n \times 0.5$
stainless steel (thickness 2mm)	$S_n \times 0.9$

With the PRO series, changes in material have only a slight impact on the switching distance.

## 6 CORRECTION FACTORS

Correction factors specify the reduction in the switching distance, if other materials than St37 are used. The change in the switching distance depends on the type, composition (internal structure), size and the geometry of the material that is to be detected.

Typical correction factors are: St:1 V2A: approx. 0.7, Ms: approx. 0.4, Al: approx. 0.3, Cu: approx. 0.2. In order to assess the approximate switch-ing distance on the materials which differ from St37, the switching distance for St37 has to be multiplied by the appropriate correction factor.

## 7 SWITCHING FREQUENCY

The switching frequency states the maximum number of available switching operations per second. Every switching operation of the inductive proximity switch triggers the oscillating circuit. The time needed for the oscillation puts a limit on the switching frequency. For half the nominal switching distance the pulse to pause ratio should be at least 1 : 2. i.e. when choosing the right proximity switch, a compromise needs to be made between the size of the sensor and the switching frequency.

General rule: The larger the sensor, the lower the switching frequency. Furthermore, the switching frequency is a measure for assessing possible use, e.g. for monitoring rotational speed or detecting fast movements.

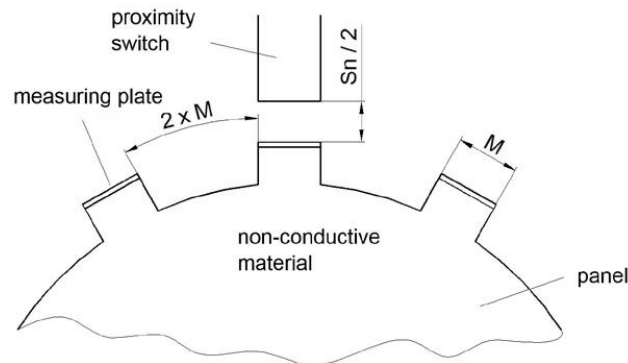

## 8 CABLE ROUTING

The connection lines of the proximity switches should not run parallel in a cable duct to lines via which induc-tive loads are switched (e.g. contactor coils, solenoid valves, motors, etc.) or via which currents of electronic motor drives are carried. In this context, it is advisable to maintain a distance of  $>100\text{mm}$  to cables with po-tential disturbing influences. In addition, the lines should be as short as possible. However, if installed favorably (low coupling capacitance, low interference voltages), the line lengths can be up to 300 meters.

**8.1 ELECTRICAL CONNECTION**

The electrical connection of the proximity switches takes place either through a directly connected cable, a M5-connector, M8-connector, M12-connector or a Lemo-connector for high-temperature applications or through a MC-connector for 230VAC applications.

**8.2 TIGHTENING TORQUES**

To avoid damage when mounting proximity switches, never exceed the specified tightening torques.

**stainless steel thread**

M4 = 1.5Nm  
M5 = 2Nm  
M8 = 10Nm  
M12 = 20Nm  
M18 = 55Nm

**brass thread nickel-plated/chrome-plated**

M8 = 7Nm  
M12 = 15Nm  
M18 = 40Nm  
M30 = 200Nm

**plastic thread**

M12 = 1.5Nm  
M18 = 3Nm  
M30 = 5Nm

**8.3 ACTIVE SWITCHING ZONE / ACTIVE SURFACE**

The active switching zone is the area in front of the active surface within which the proximity switch reacts to the approach of metal parts, i.e. changes the switching state of the output.

**8.4 REPEAT ACCURACY**

The repeat accuracy (according to IEC 60947-5-2 / EN 60947-5-2) is the repeat accuracy of the real switching distance  $S_r$  over a period of 8 hours at an ambient temperature of 23°C ( $\pm 5^\circ\text{C}$ ) and a defined operating volt-age.

The specified repeat accuracy corresponds to this definition. Generally the repeat accuracy is considerably better in case of sequent measurements.

**8.5 REVERSE POLARITY AND SHORT-CIRCUIT PROTECTION (DC DEVICES)**

An internal protection prevents destruction of the proximity switch if the connection lines are accidentally swapped.

The short-circuit protection (DC devices) prevents destruction of the proximity switch in case of an overcurrent.

## **9 OVERVIEW OF INDUCTIVE SENSORS**

The following section provides an overview of inductive sensors, their characteristics, features and potential fields of application.

### **9.1 UP TO 3-FOLD NORM SWITCHING DISTANCE**

These inductive sensors with switching distances from 1mm to 40mm can be used up to 3-fold norm switching distance at ambient temperatures of -25°C to +70°C. The active surface (sensor head) is made of plastic.

The devices are available as round or threaded devices as well as in cuboid design in sizes from 3mm (round devices) to M30 x 1.5 and can be mounted flush, semi-flush and non-flush. These sensors are suitable for applications in which standard sensors cannot be used on account of their limited range.



Sensors for use up to 3-fold norm switching distance.

### **9.2 UP TO 4-FOLD NORM SWITCHING DISTANCE**

The threaded devices in sizes M8 x 1 and M12 x 1 can be used up to 4-fold norm switching distance. The switching distance of the semi-flush-mountable sensors with active surface made of plastic ranges from 4mm to 8mm, whereby the devices can withstand temperatures of -25°C to +70°C. These devices can, like the sensors with 3-fold norm switching distance, be used in applications where the use of standard sensors is not recommended (limited range).



The threaded devices can be used up to 4-fold norm switching distance.

### **9.3 WITH METALLIC SENSOR SURFACE / FULL METAL HOUSING**

Like the housing, the active surface of these sensors is also made of metal. With the devices from this product family which have up to 3-fold norm switching distance, changes in material barely have an effect on the switching distance (from 3mm to 40mm).

The devices for operating temperatures from -25°C to +130°C are available as round or threaded devices or as a cuboid version in sizes from 6.5mm (round) to M30 x 1.5 and can be mounted flush, semi-flush or non-flush.

As these sensors are particularly robust and leaktight, they are frequently used in applications with hostile environmental conditions, e.g. in machining (drilling with cutting oil, etc.). The sensors are also suitable for use in the food industry as they have a high impermeability and chemical resistance and can therefore with-stand the jets of high-pressure cleaners.



Not only the sensor but also the active surface is made of metal.

### **9.4 ACID AND ALKALINE-RESISTANT**

These acid and alkaline-resistant sensors are characterized by the special choice of materials as well as high impermeability and, in addition, can be subjected to mechanical loads. The devices for specific environmental conditions in round, threaded and cuboid design are available in sizes from 6.5mm (round) to M30 x 1.5 with switching distances from 2mm to 40mm. The active surface of the flush-mountable, semi-flush-mountable and non-flush-mountable sensors is made of metal or Teflon; the operating temperature range is from -25°C to +120°C.

The weatherproof sensors (middle in the figure) are made of V4A stainless steel, and the connection and cable sheathing of Teflon. These sensors retain their impermeability even with major temperature fluctuations and are therefore used not only outdoors but also for e.g. product testing in climatic chambers. Owing to the materials used for the housing, the sensors are also used in zones with aggressive environmental conditions, such as in salt water, in roll stands of cold-rolling mills or in coating systems.

For applications where not even V4A provides sufficient resilience, full-Teflon devices are also available which can be used as position sensors for hydrochloric acid baths in galvanizing plants.



The acid and alkaline-resistant sensors are characterized by a high level of impermeability. The weatherproof sensors are in the middle.

**9.5 FOR EXTENDED OPERATING TEMPERATURE RANGE UP TO +180°C**

The sensors for use in temperature ranges  $>110^{\circ}\text{C}$  are available as threaded devices or as compact cuboid solutions in sizes from M8 x 1 to M80 x 1.5. As these devices can, depending on the version, withstand temperatures of  $-25^{\circ}\text{C}$  to  $+180^{\circ}\text{C}$  (single-piece systems with fully integrated electronics), they are particularly suitable for use in applications in which the sensors need to have a high temperature resistance. Devices with an active surface made of metal for an operating temperature range of  $-25^{\circ}\text{C}$  to  $+130^{\circ}\text{C}$  are also available.

A few examples of possible fields of application are speed control in oven conveyors, position monitoring of oven flaps, closure control in plastic injection molding tools as well as the monitoring of valve positions on injection tools. The sensors with switching distance of 2 to 50mm can be mounted both flush and non-flush.

Furthermore, since 2012 the product range has included two cuboid sensors which have a plastic sensor head, fully integrated electronics for operating temperatures up to a maximum of  $+150^{\circ}\text{C}$  and an operating range of 25mm. The electrical connection of these devices is made via an M12-connector. In addition, special cable sockets for use in energy chains are available for temperatures up to  $+150^{\circ}\text{C}$ .



The sensors can withstand temperatures of  $-25^{\circ}\text{C}$  to  $+180^{\circ}\text{C}$  (single-piece systems with fully integrated electronics).

**TWO-PIECE SYSTEMS UP TO +230°C**

The family of inductive sensors for the extended operating temperature range  $>110^{\circ}\text{C}$  includes two-piece systems up to  $+230^{\circ}\text{C}$ . The flush-mountable and non-flush-mountable threaded devices in sizes from M18 x 1 to M50 x 1.5 have an active surface made of plastic and can be used from  $0^{\circ}\text{C}$  to max.  $+230^{\circ}\text{C}$ .

Typical areas of application are, for example, drying systems on painting lines or in powder-coating facilities, whereby versions used in these applications are characterized by their silicone-free design.



The two-piece systems are suitable for operating temperatures up to  $+230^{\circ}\text{C}$ .

### **9.7 WELDING-RESISTANT VERSIONS**

The welding-resistant (magnetic-field resistant) threaded sensors for flush and non-flush mounting with active surface made of plastic are available in sizes from M8 x 1 to M30 x 1.5. They are suitable for operating temperatures from -25°C to +70°C and are used on welding apparatus and on eddy current systems.



Welding-resistant and magnetic-field resistant sensors.

### **9.8 DISTANCE-MEASURING SENSORS**

The threaded devices for contactless distance measurements, e.g. on grippers or cylinders, are available in sizes from M8 x 1 to M30 x 1.5. They have an active surface made of plastic and measuring ranges from 4mm to 20mm. The semi-flush-mountable sensors incorporate analog outputs from 0 to 10V (4 to 20mA) and can withstand temperatures of -25°C to +70°C. Using these sensors, metallic objects can be easily positioned or their dimensions checked.



The sensors for distance measurements have measuring ranges of 4mm to 20mm.

**9.9 HIGH-PRESSURE RESISTANT DEVICES FOR HYDRAULIC CYLINDERS**

The flush-mountable threaded devices are used e.g. for monitoring the position of the piston rod in hydraulic cylinders. In this case, the devices are screwed into the cylinder housing and detect the piston rod as it moves past the sensor surface. The hydraulic oil pressure of max. 500bar (peak pressure 800bar) which acts on the active surface is a particularly tough challenge for the sensor housing seal.

The devices are available in sizes from M5 x 0.5 to M18 x 1. The most commonly used version in size M12 x 1 has an active sensor surface made of stainless steel; all other versions have a ceramic sensor surface. Its operating temperature range is -25°C to +80°C. The versions with an active surface made of stainless steel, however, can be used up to +100°C.



These sensors can withstand pressures up to 500bar.

### 9.10 RING-SHAPED VERSIONS

These sensors are used for detecting small parts such as screws or nails, e.g. in feed or ejection control, or for parts counting. The devices are also used for detecting wire breaks, to name just a few possible applications.

The cuboid sensors are available with ring diameters of 4mm to 100mm and operate in static mode (sensor remains active for as long as a part is in the detection range) and in dynamic mode (sensor only switches when parts pass through the sensor ring). To ensure the optimum detection of small parts, the sensor has pulse stretching up to 130ms. The operating temperature range is -25°C to +70°C.



The ring-shaped sensors are especially suitable for the detection of small parts.

### 9.11 HOSE MOUNTING

The range of ring sensors includes devices for hose mounting. Typical applications for these sensors, which are designed for operating temperatures of 0°C to +55°C and for mounting to hoses with a diameter up to 16mm, are feed or ejection control as well as the counting of small parts. The cuboid devices operate both in static mode and dynamic mode. Pulse stretching up to 100ms enables the reliable detection of fast-moving parts.

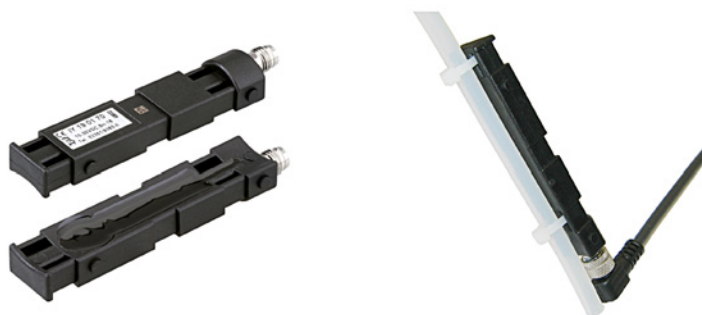

Sensors that can be attached to hoses with a diameter up to 16mm.

© ipf electronic gmbh: This white paper is protected by copyright. Use of the text (even in part) and of image material included in this document is permitted only with the written consent of ipf electronic GmbH.

